



ASSEMBLY INSTRUCTIONS
COASTER FINE FURNITURE



Fine Furniture for every stage of life

REVISION 0 :12/09/2019
REVISION 1 :04/16/2021
REVISION 2: 07/21/2022

PAGE 1 OF 4

881197
OFFICE CHAIR

COASTERFURNITURE.COM

ITEM: **881197**



ASSEMBLY INSTRUCTIONS

ASSEMBLY TIPS:

1. Remove hardware from box and sort by size.
2. Please check to see that all hardware and parts are present prior to start of assembly.
3. Please follow attached instructions in the same sequence as numbered to assure fast & easy assembly.



WARNING!







1. Don't attempt to repair or modify parts that are broken or defective. Please contact the store immediately.
2. This product is for home use only and not intended for commercial establishments.





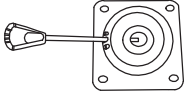

ASSEMBLY TIME

10 MINUTES



PARTS IDENTIFICATION

| | | | |
|---|-----------------|---|------|
| A | BASE |  | 1PC |
| B | LEG |  | 5PCS |
| C | CASTER |  | 5PCS |
| D | GAS CYLINDER |  | 1PC |
| E | ADJUSTING PLATE |  | 1PC |
| F | SEAT AND BACK |  | 1PC |

Z HARDWARE IDENTIFICATION

| | | | |
|---|-----------------------|---|------|
| 1 | ALLEN WRENCH (M6) |  | 1PC |
| 2 | BOLT (M6 x 20mm) |  | 4PCS |
| 3 | BOLT (M6 x 10mm) |  | 5PCS |
| 4 | WASHER (φ 6 x φ 18mm) |  | 4PCS |

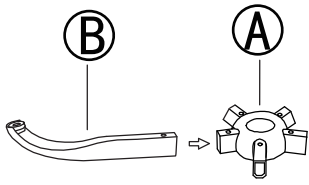
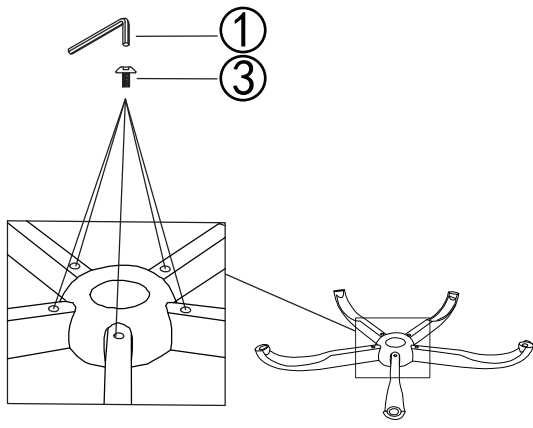
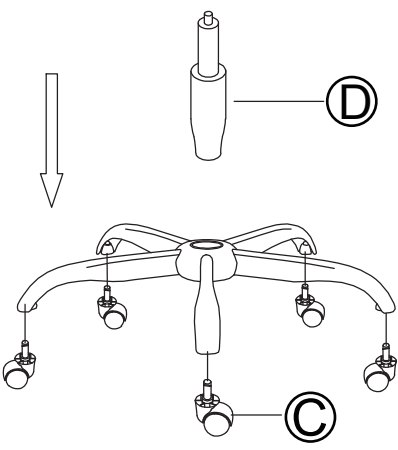
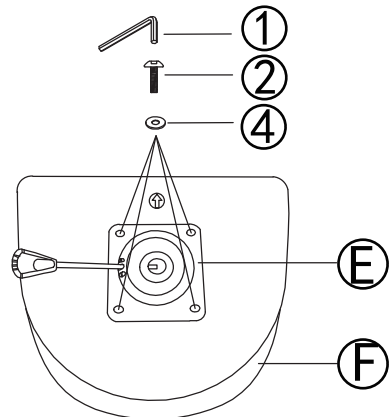
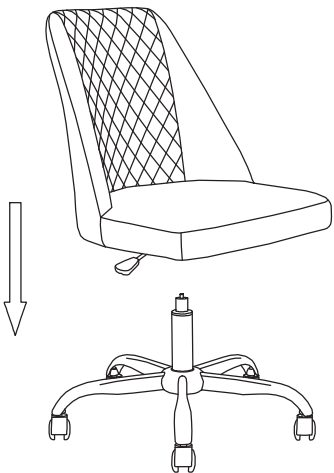
ASSEMBLY INSTRUCTIONS

| | |
|---|--|
| <p>STEP 1</p>  | <p>STEP 2</p>  |
| <p>STEP 3</p>  | <p>STEP 4</p>  |
| <p>STEP 5</p>  | <p>STEP 6</p>  |

ITEM:881197

ASSEMBLY INSTRUCTIONS

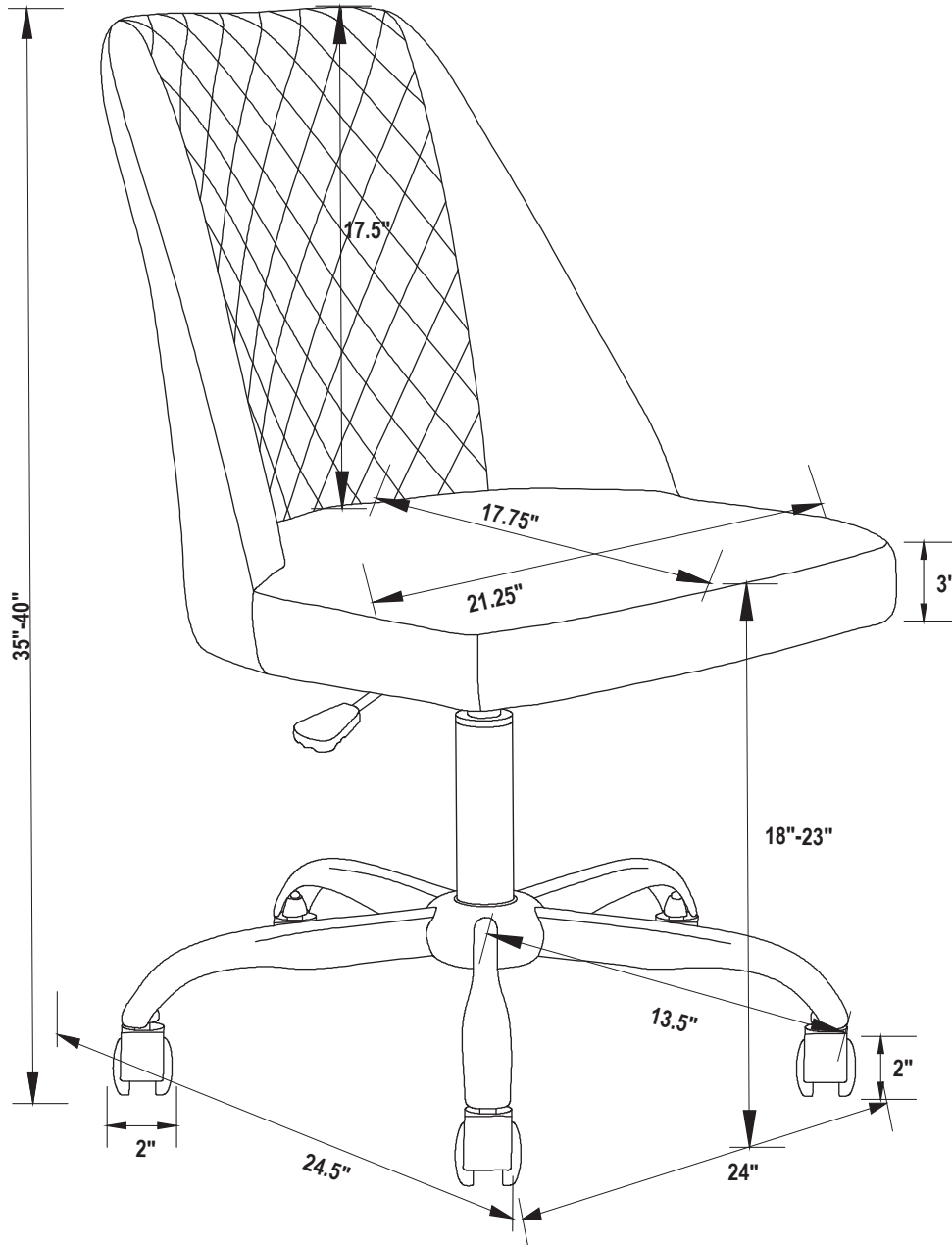

Note : Dimension tolerance $\pm 5\%$