

ASSEMBLY INSTRUCTIONS
COASTER FINE FURNITURE



Fine Furniture for every stage of life

723283
TV CONSOLE

ITEM: 723283

ASSEMBLY INSTRUCTIONS

ASSEMBLY TIPS:

1. Remove hardware from box and sort by size.
2. Please check to see that all hardware and parts are present prior to start of assembly.
3. Please follow attached instructions in the same sequence as numbered to assure fast & easy assembly.



WARNING!

1. Don't attempt to repair or modify parts that are broken or defective. Please contact the store immediately.
2. This product is for home use only and not intended for commercial establishments.



ASSEMBLY TIME

40 MINUTES

MAX TV SIZE: 75"

PARTS IDENTIFICATION

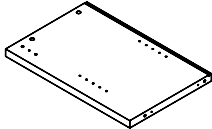
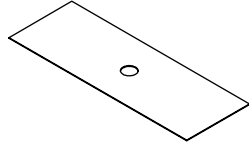
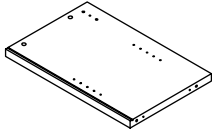
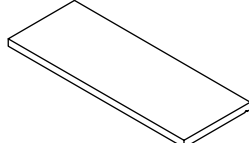
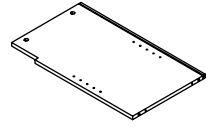
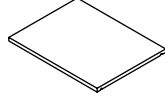
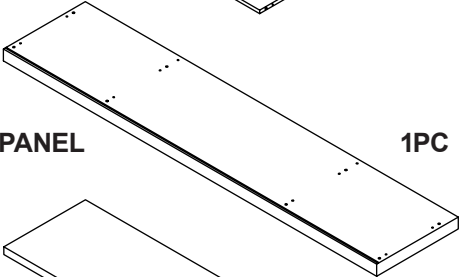
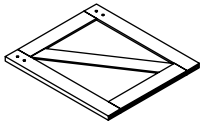
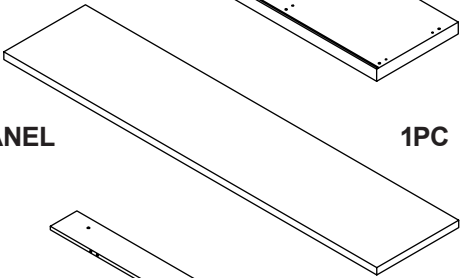
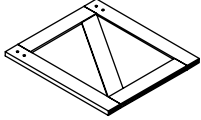
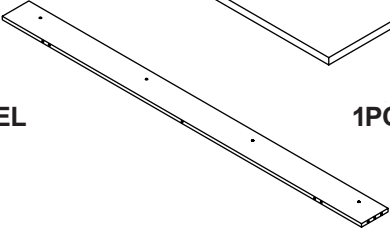
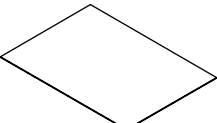







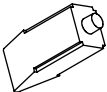

A	LEFT SIDE PANEL		1PC	H	MIDDLE BACK PANEL		2PCS
B	RIGHT SIDE PANEL		1PC	I	LARGE ADJUSTABLE SHELF		1PC
C	DIVIDER PANEL		2PCS	J	SMALL ADJUSTABLE SHELF		2PCS
D	BOTTOM PANEL		1PC	K	LEFT DOOR		1PC
E	TOP PANEL		1PC	L	RIGHT DOOR		1PC
F	CROSS PANEL		1PC				
G	BACK PANEL		2PCS				

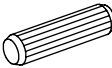
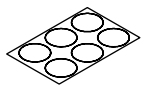
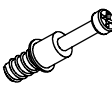
NOTE:

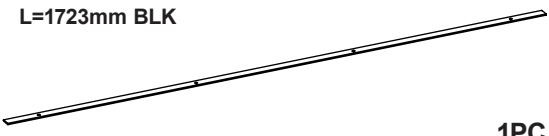
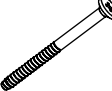
Phillips head screw driver is required in the assembly process; however, manufacturer does not provide this item.

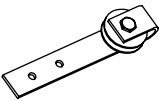
ITEM:723283

HARDWARE IDENTIFICATION

Z							
NO	DESCRIPTION	FIGURE	Q'TY	NO	DESCRIPTION	FIGURE	Q'TY
1	GLUE 40g		1PC	10	ALLEN WRENCH 4mm SR		1PC
2	WOODEN DOWEL ø8x30mm		22PCS	11	STICKER ø20mm		3PCS
3	CAM BOLT ø7x35.5mm SR		13PCS	12	FOOT ø35xH19mm		6PCS
4	CAM LOCK ø15x12mm SR		13PCS	13	TRACK BAR L=1723mm BLK		1PC
5	BOLT ø9.5x55mm SR		8PCS	14	TRACK SPACER ø25x25mm BLK		4PCS
6	PIN FOR ADJUSTABLE SHELF ø4.9x8mm SR		12PCS	15	ROLLER ø40.5x160mm BLK		4PCS
7	PIN FOR DOOR ø5.8x25mm BLK		2PCS	16	I BAR L=848mm		1PC
8	LONG BOLT M6x44mm BLK		4PCS				
9	SHORT BOLT M6x20mm BLK		8PCS				

Z12,Z13,Z14,Z15,Z16 not included in blister packaging.

NOTE:

Phillips head screw driver is required in the assembly process; however, manufacturer does not provide this item.

ITEM: 723283

STEP 1

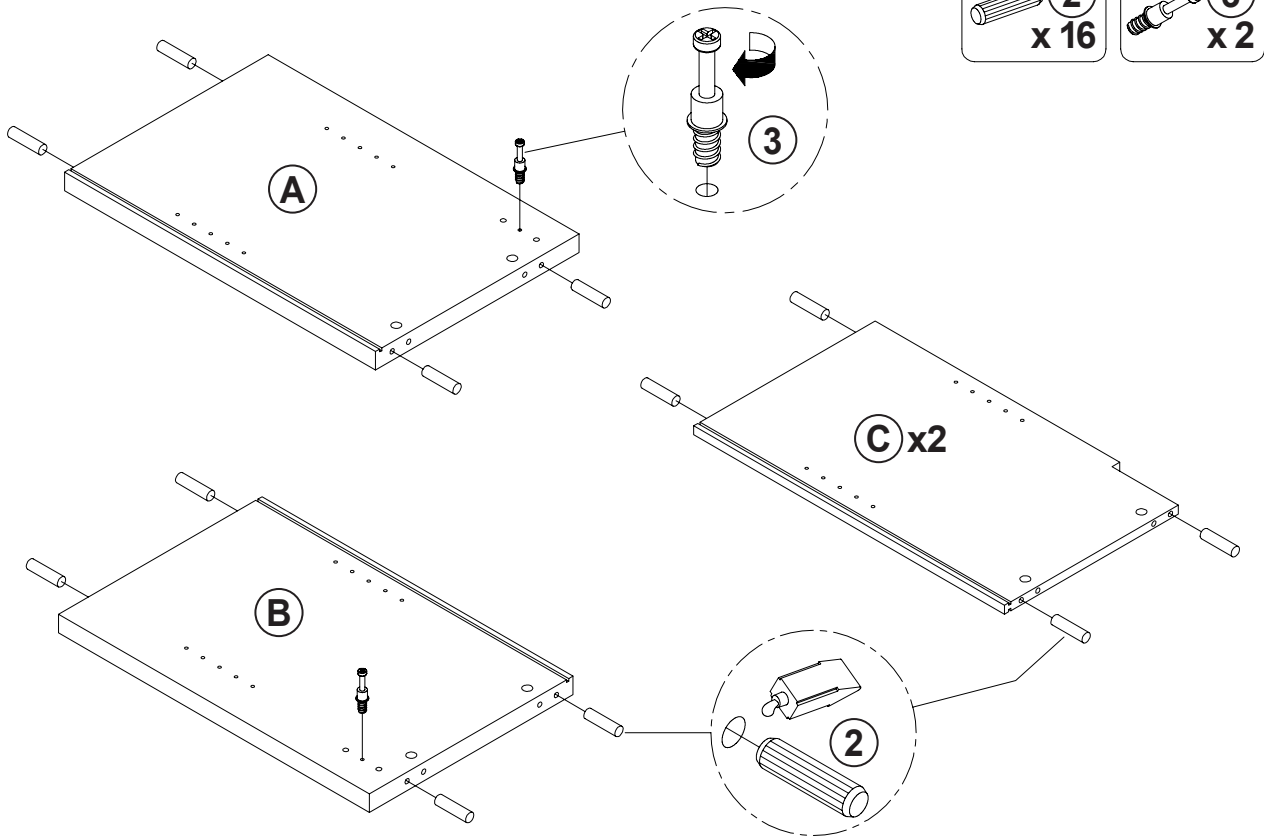

STEP 2

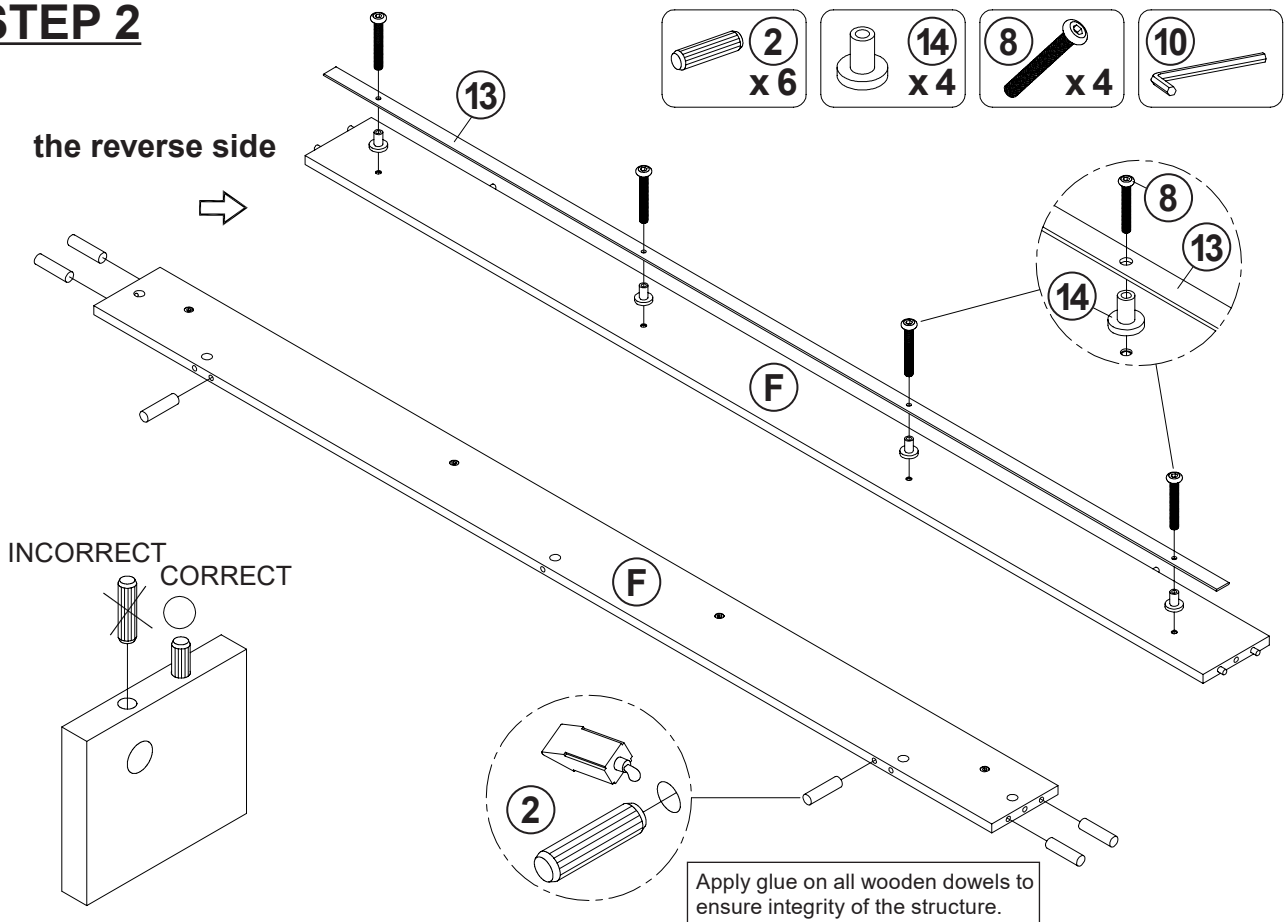

ITEM: 723283

STEP 3

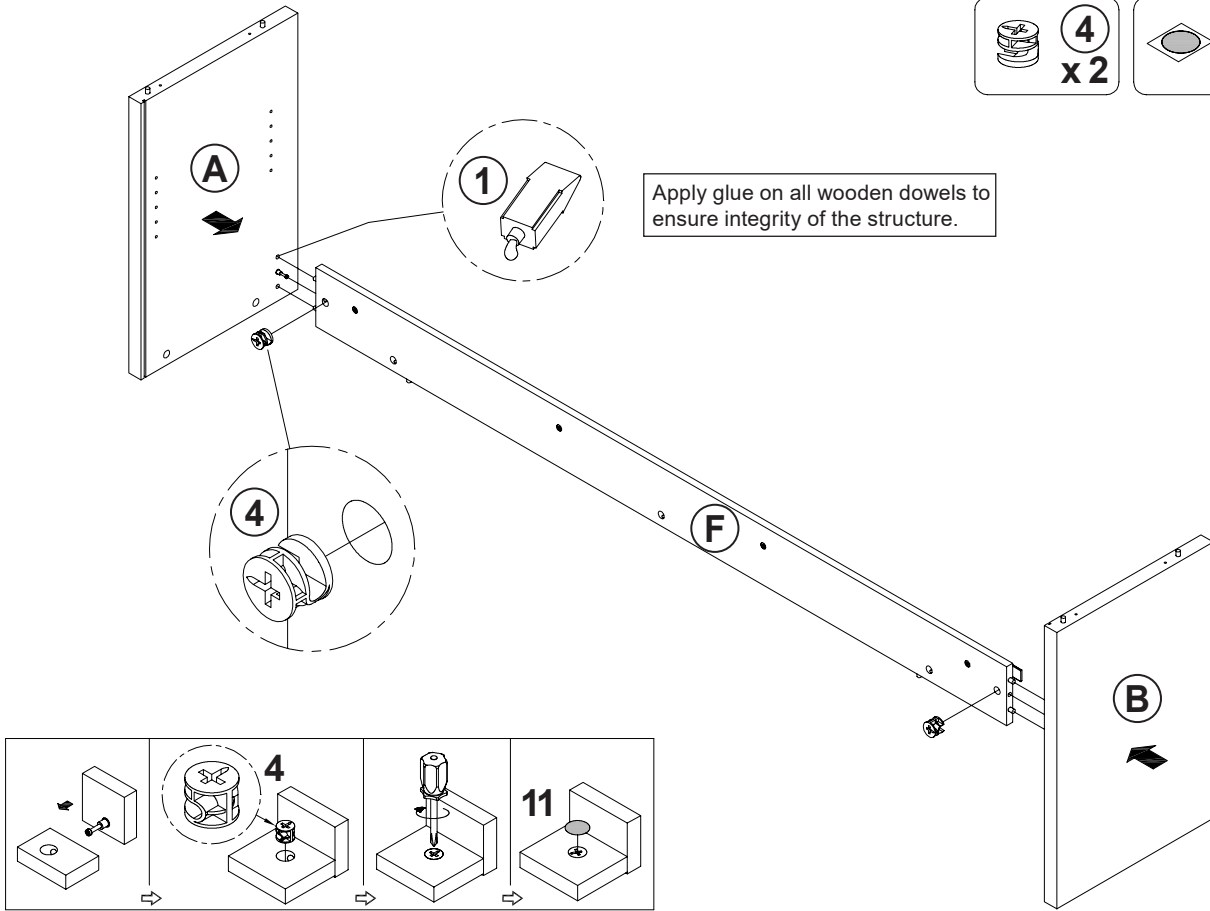
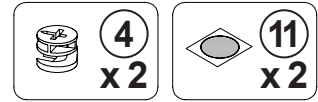

STEP 4

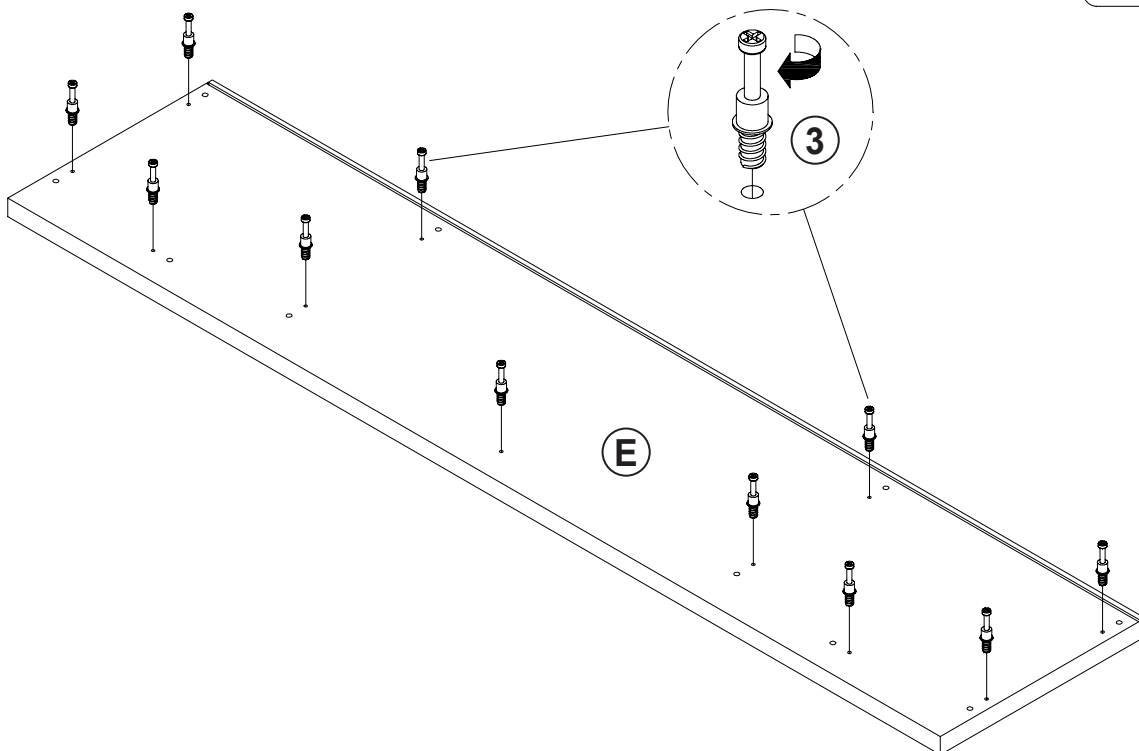
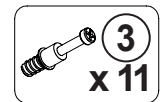

ITEM: 723283

COASTER
FINE FURNITURE

STEP 5

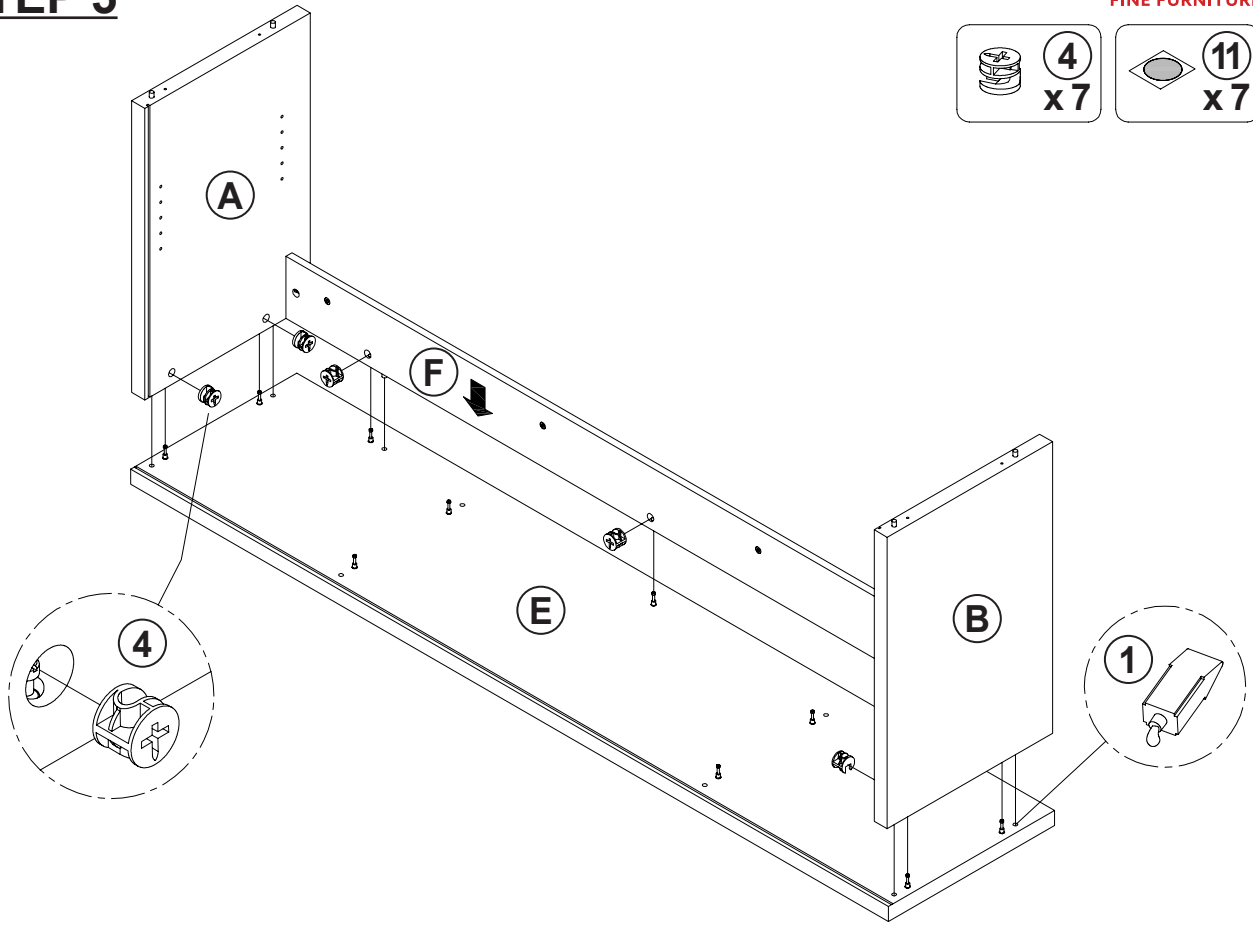

STEP 6

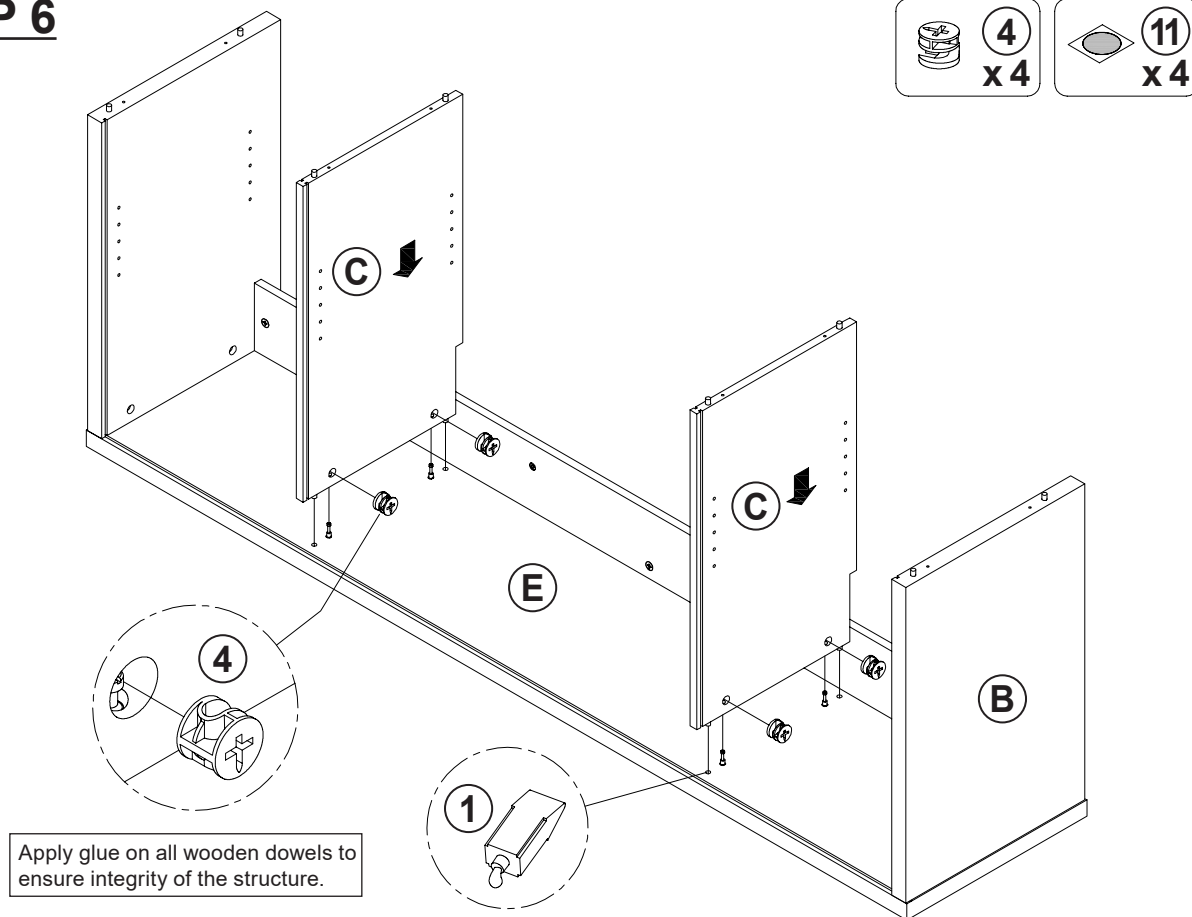

Apply glue on all wooden dowels to ensure integrity of the structure.

ITEM: 723283

STEP 7

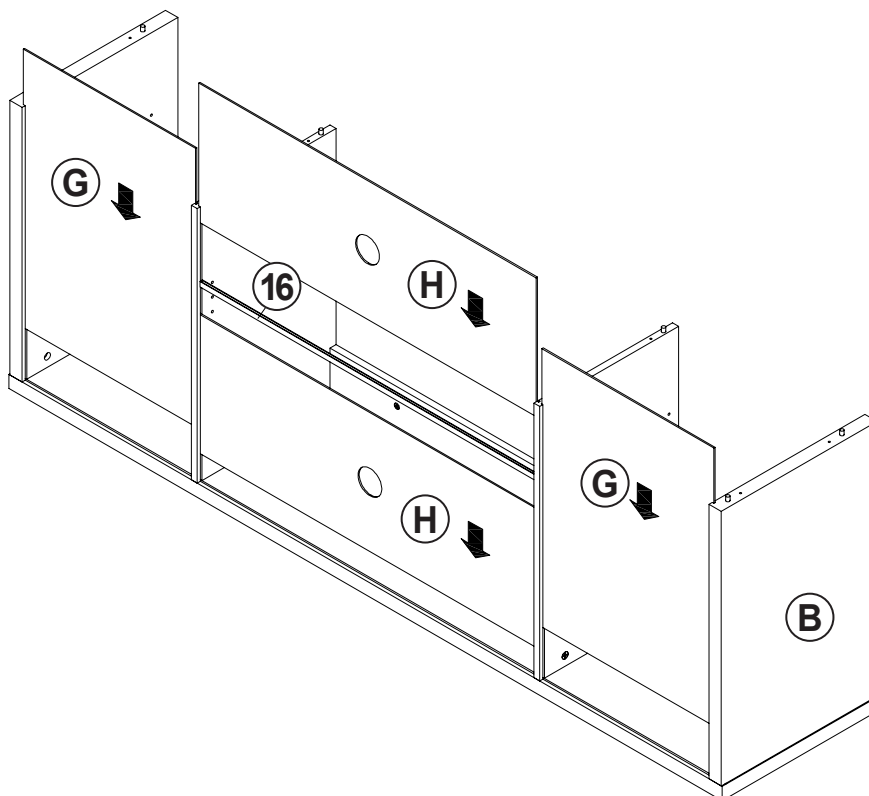

STEP 8

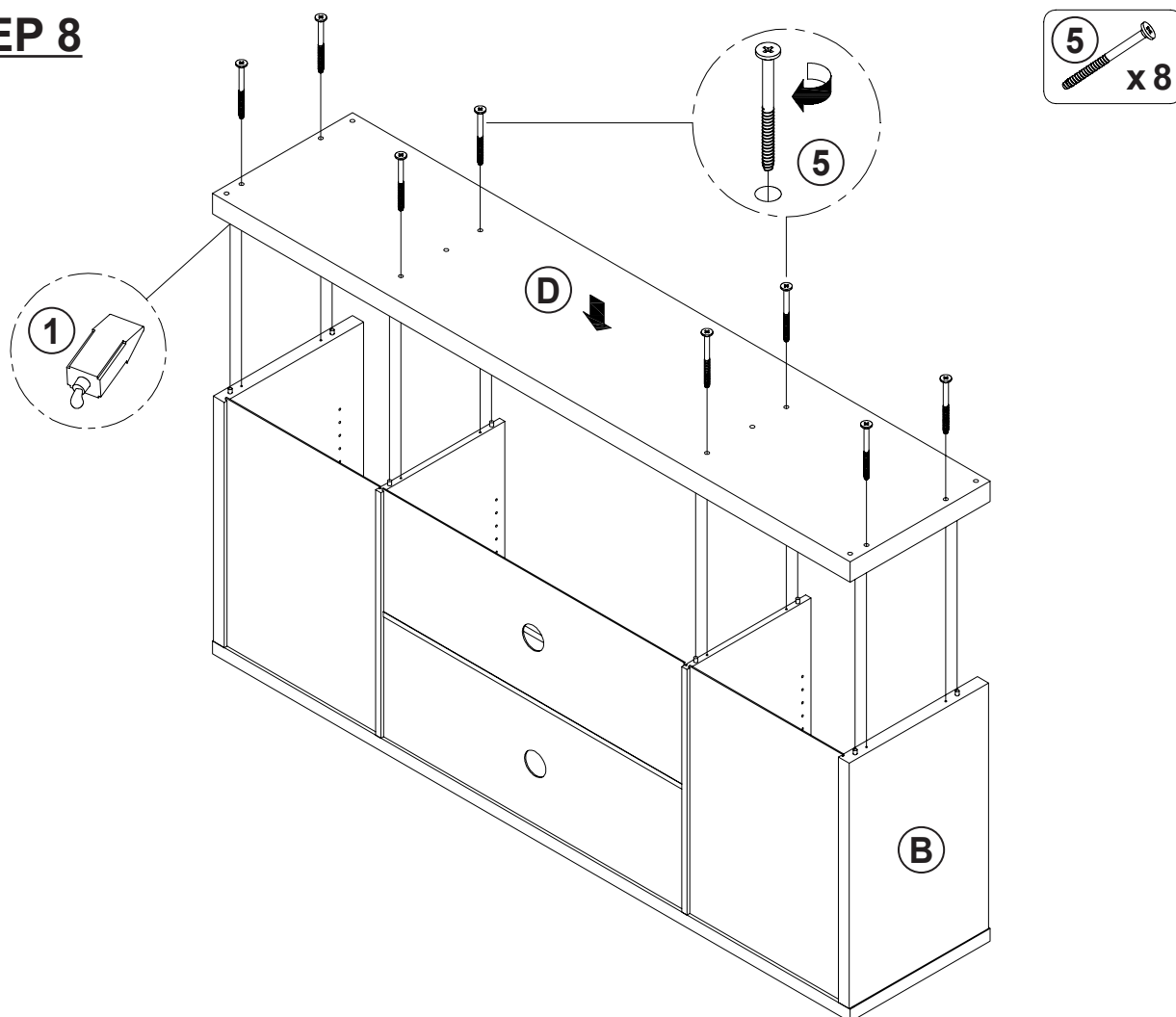

ITEM: 723283

COASTER
FINE FURNITURE

STEP 9

12
x 6

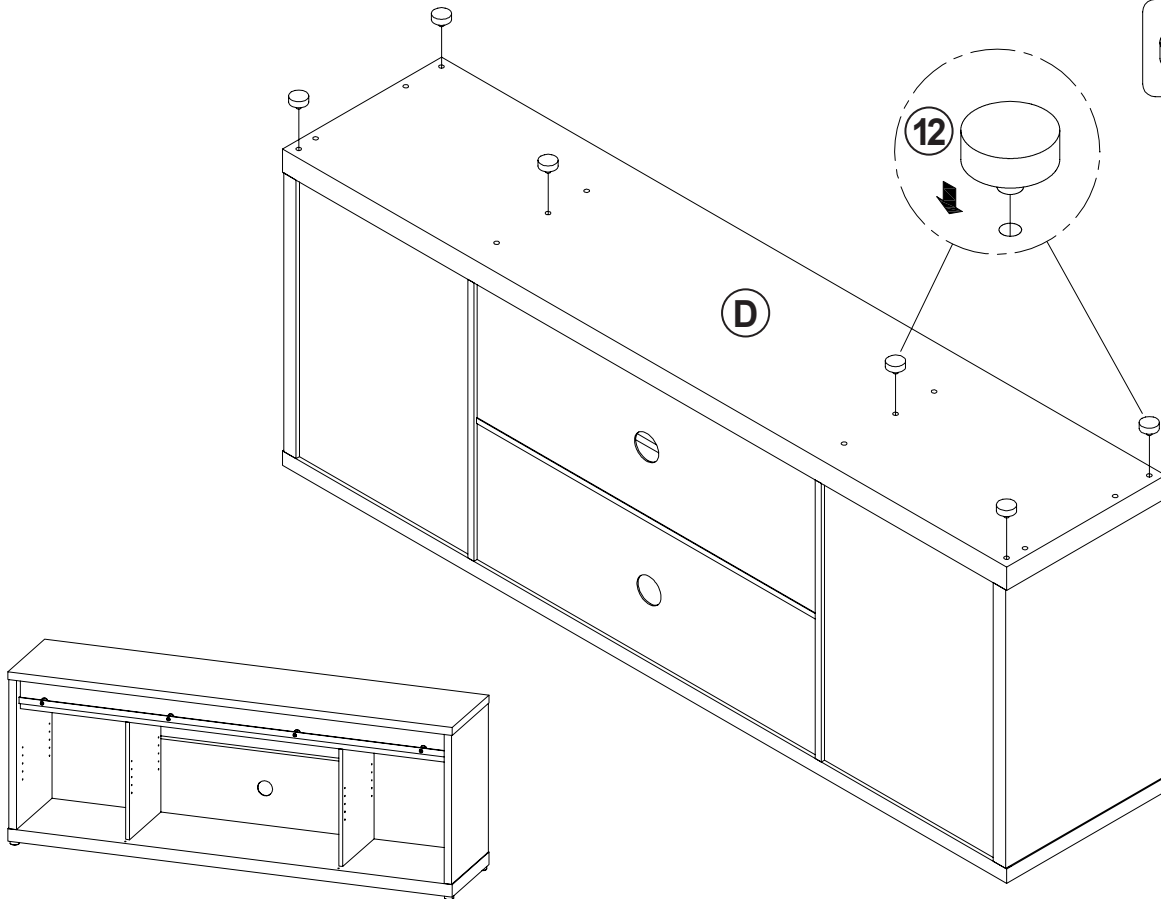

STEP 10

6
x 12

7
x 2

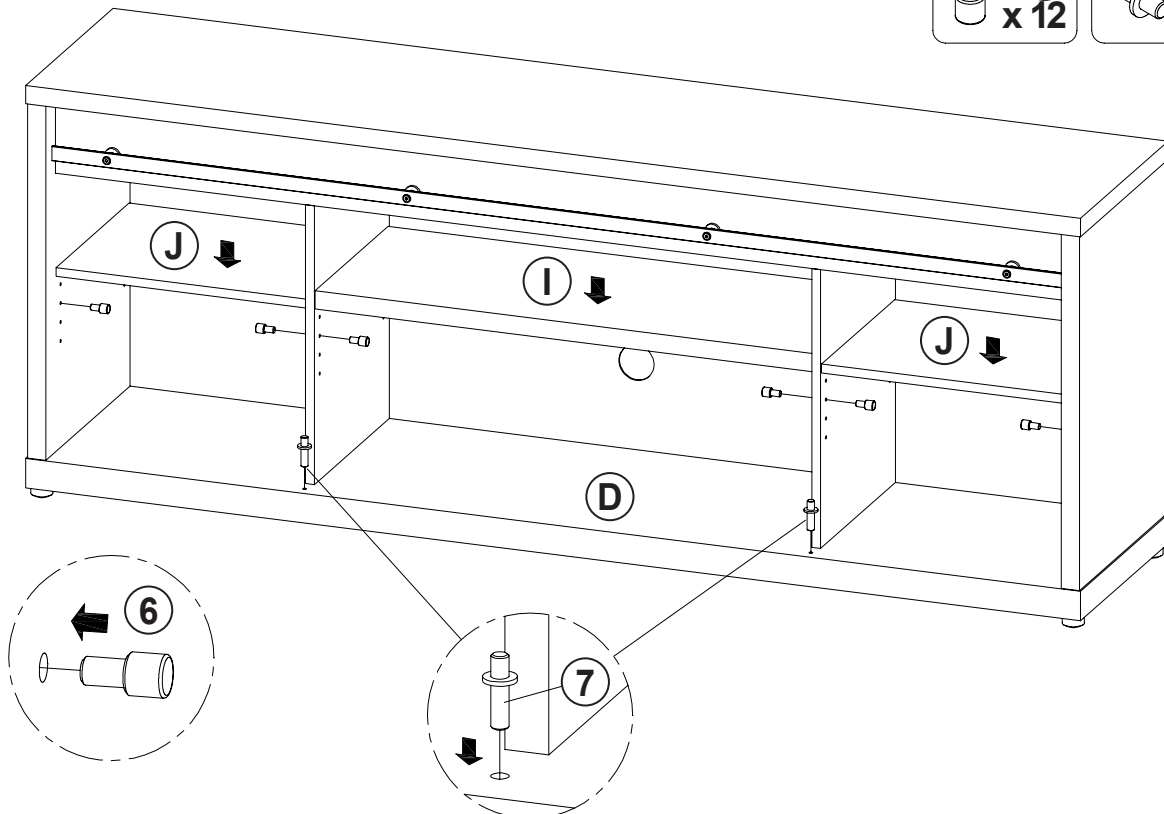

ITEM: 723283

STEP 11

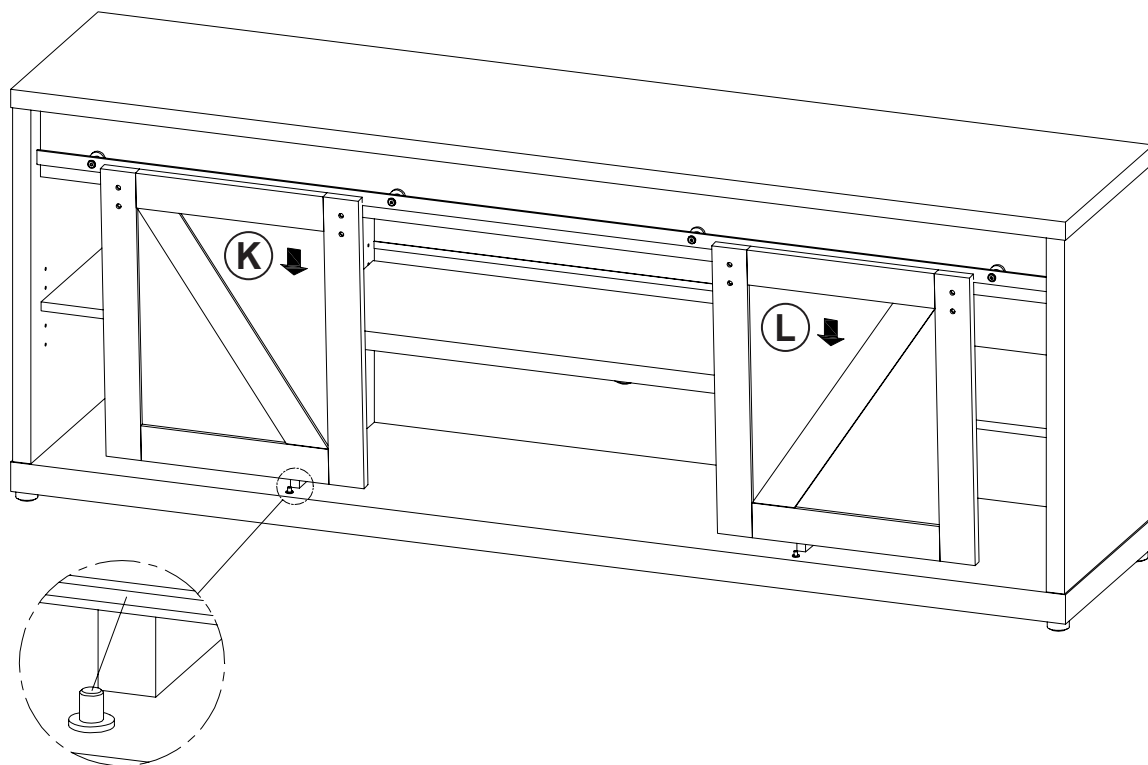

STEP 12

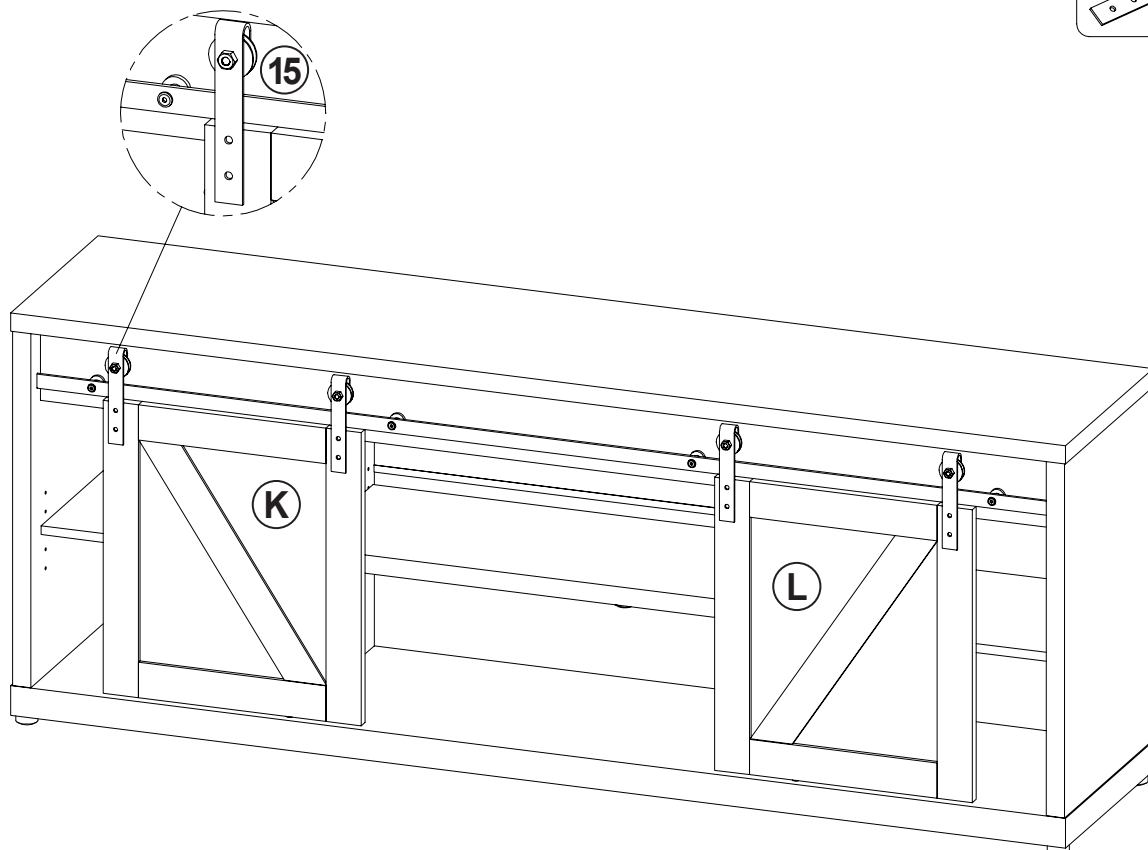
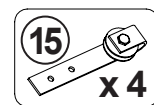

ITEM: 723283

COASTER
FINE FURNITURE

STEP 13

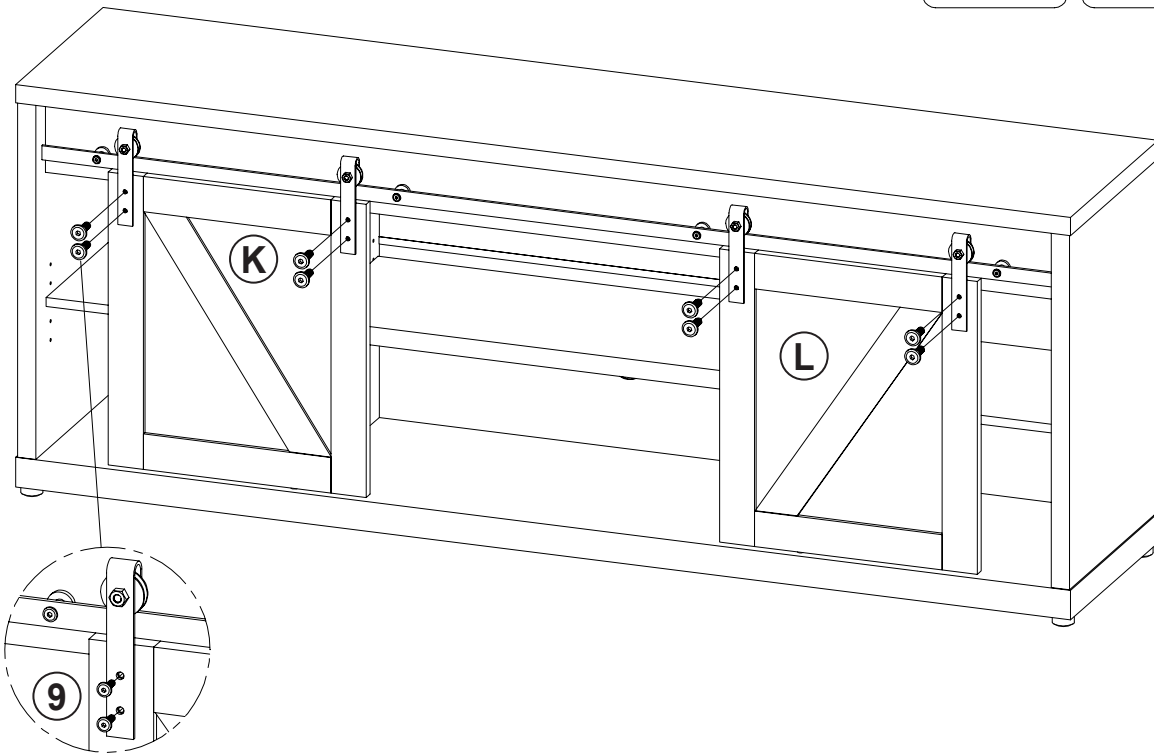
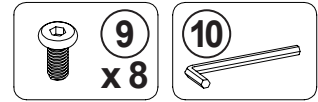

STEP 14
COMPLETE

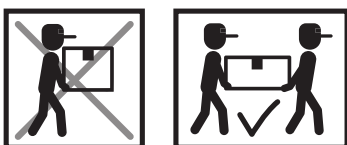
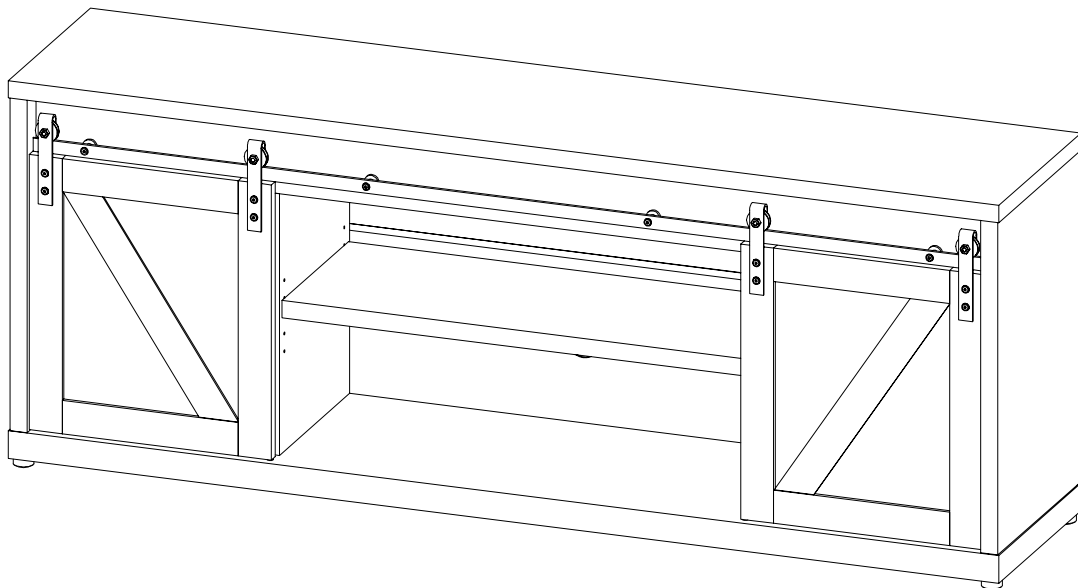

ITEM: 723283

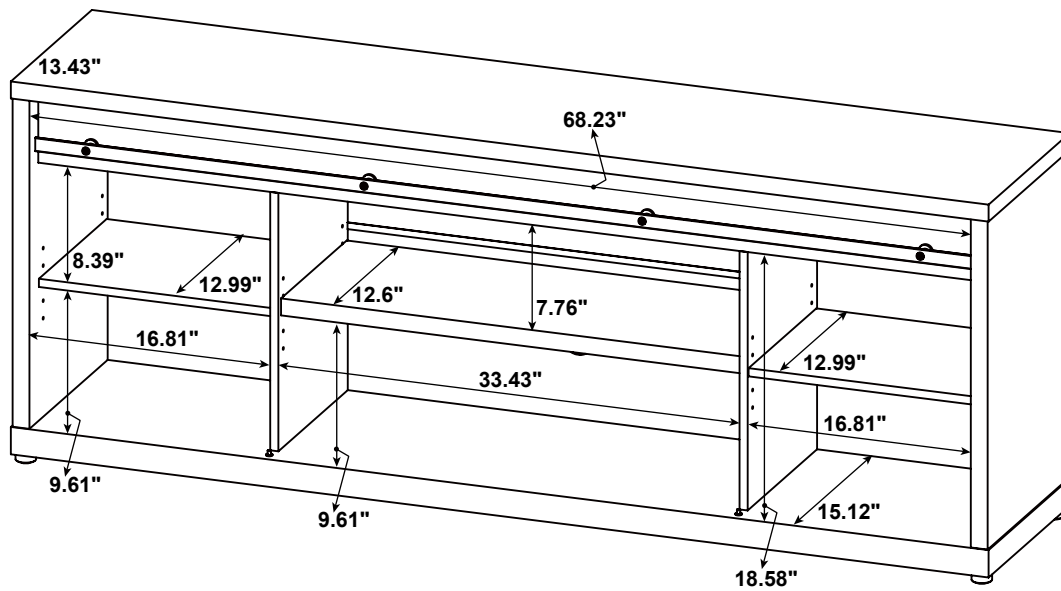
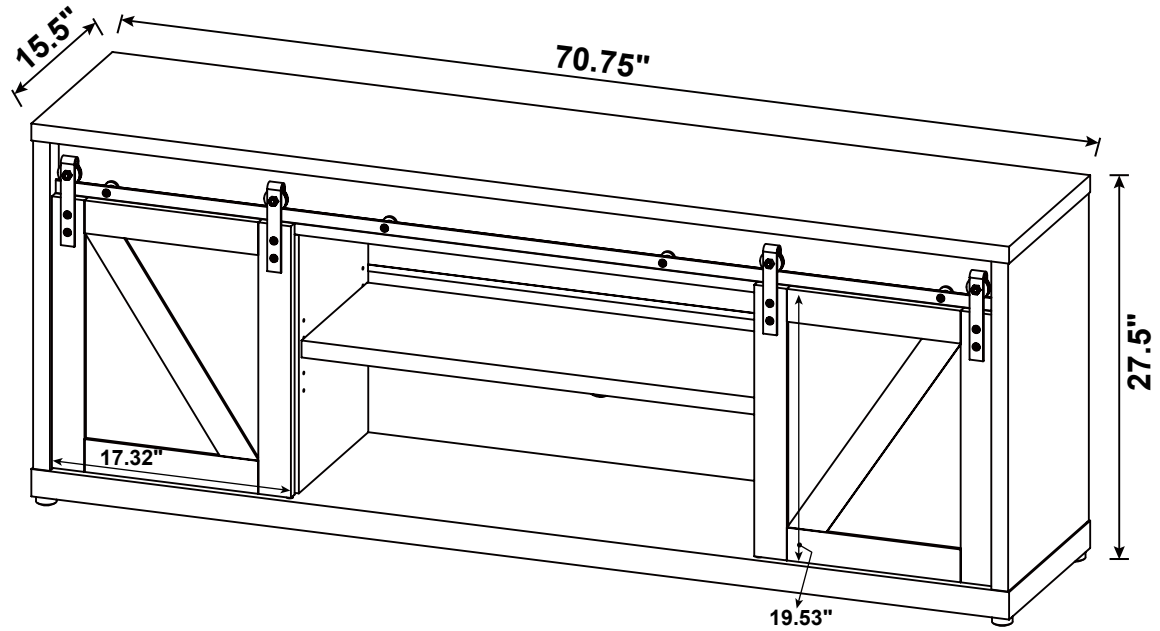

Note : Dimension tolerance $\pm 5\%$

ANTI-TIPPING INSTALLMENT INSTRUCTIONS

FURNITURE TIPPING RESTRAINT

WARNING

Injury may result from tipping furniture.
This restraint may protect against tipping furniture.
Do not allow children to climb on furniture.
This restraint is not a substitute for proper adult supervision.
Failure to detach this restraint before moving the furniture
may result in injury and damage.

1. To attach the anti-tip strap, securely mount one end to the top of the case piece with the 5/8" screw.
2. Position the case piece against the wall in the desired location.
3. Pull the anti-tip strap taut and mark the position of where you will secure the other end on the wall.
4. Drill a 1-1/4" hole in the spot you marked.
5. Tap in plastic wall plug.
6. Fasten anti-tip strap with wall screw provided.

(Please install the anti-tipping kit in the middle of the case piece if only have one set of anti-tipping kit.)

