

ASSEMBLY INSTRUCTIONS
COASTER FINE FURNITURE

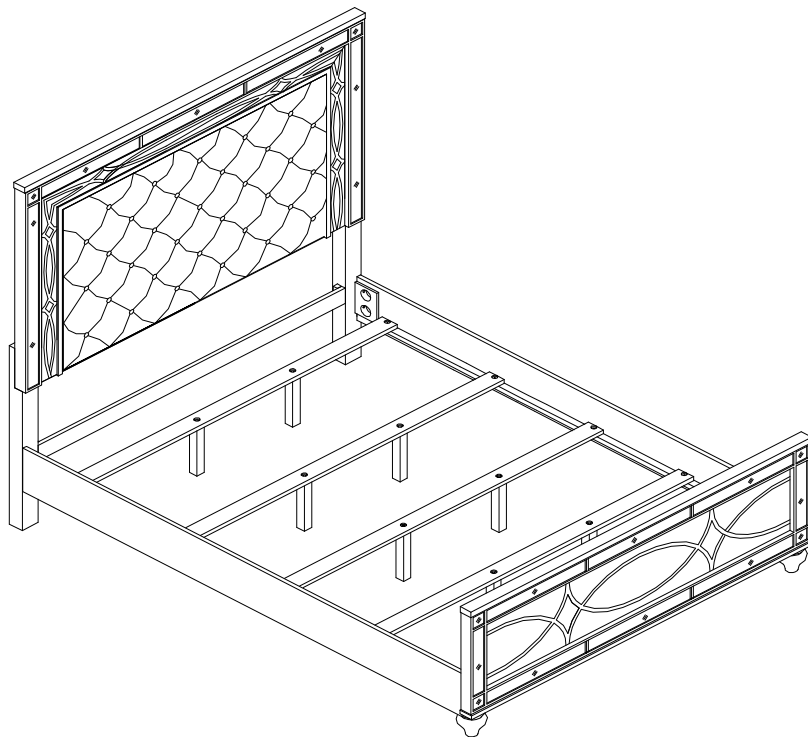

Fine Furniture for every stage of life

223211KW(B1-B3)
California King Bed

ITEM: 223211KW (B1-B3)



ASSEMBLY INSTRUCTIONS

ASSEMBLY TIPS:

1. Remove hardware from box and sort by size.
2. Please check to see that all hardware and parts are present prior to start of assembly.
3. Please follow attached instructions in the same sequence as numbered to assure fast & easy assembly.



WARNING!

1. Don't attempt to repair or modify parts that are broken or defective. Please contact the store immediately.
2. This product is for home use only and not intended for commercial establishments.

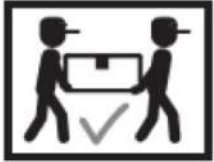



ASSEMBLY TIME

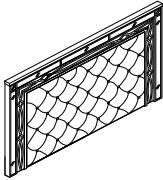

30 MINUTES

PARTS IDENTIFICATION

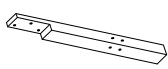
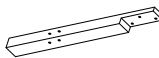

B1 (BOX 1)

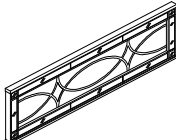
<p>A HEADBOARD PANEL</p>  <p>1PC</p>	<p>B HEADBOARD BOTTOM RAIL</p>  <p>1PC</p>
<p>C RIGHT HEADBOARD LEG</p>  <p>1PC</p>	<p>D LEFT HEADBOARD LEG</p>  <p>1PC</p>

B2 (BOX 2)

<p>E FOOTBOARD PANEL</p>  <p>1PC</p>	<p>F FOOTBOARD BUN FOOT</p>  <p>2PCS</p>
--	--

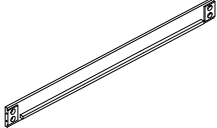
B3 (BOX 3)

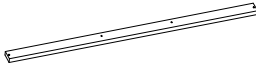
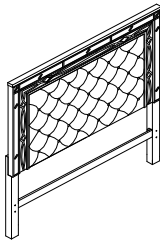
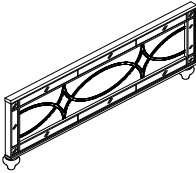
<p>G BED RAIL</p>  <p>2PCS</p>	<p>H BED SLAT SUPPORT WITH LEVELER</p>  <p>8PCS</p>
<p>I BED SLAT</p>  <p>4PCS</p>	<p>HB 223211KW (B1) FROM BOX 1 HEADBOARD COMPLETE</p>  <p>1PC</p>
<p>FB 223211KW (B2) FROM BOX 2 FOOTBOARD COMPLETE</p>  <p>1PC</p>	

ITEM: 223211KW (B1-B3)



ASSEMBLY INSTRUCTIONS

ASSEMBLY TIPS:

1. Remove hardware from box and sort by size.
2. Please check to see that all hardware and parts are present prior to start of assembly.
3. Please follow attached instructions in the same sequence as numbered to assure fast & easy assembly.







WARNING!



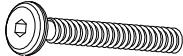

1. Don't attempt to repair or modify parts that are broken or defective. Please contact the store immediately.
2. This product is for home use only and not intended for commercial establishments.

HARDWARE IDENTIFICATION

Z-B1 (BOX 1) - HARDWARE PACK IS LOCATED IN 223211KW (B1)

1	BOLT ($\Phi 5/16''$ x 50mm - RBW)		10PCS	2	LOCK WASHER ($\Phi 5/16''$ - RBW)		10PCS
3	FLAT WASHER ($\Phi 5/16''$ - RBW)		10PCS	4	ALLEN WRENCH (4MM - RBW)		1PC

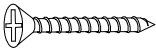
Z-B3 (BOX 3) - HARDWARE PACK IS LOCATED IN 223211KW (B3)

5	THREADED BOLT ($\Phi 5/16''$ x 3-1/2'' - RBW)		8PCS	6	HALF ROUND NUT ($\Phi 5/16''$ - RBW)		8PCS
7	WRENCH (14MM - RBW)		1PC	8	FLAT HEAD SCREW ($\Phi 4$ x 30mm - RBW)		8PCS
9	HEX NUT ($\Phi 5/16''$ x 14mm - RBW)		8PCS				

NOTE:

Phillips head screw driver is required in the assembly process; however, manufacturer does not provide this item.

ITEM: 223211KW (B1-B3)

ASSEMBLY INSTRUCTIONS

STEP 1

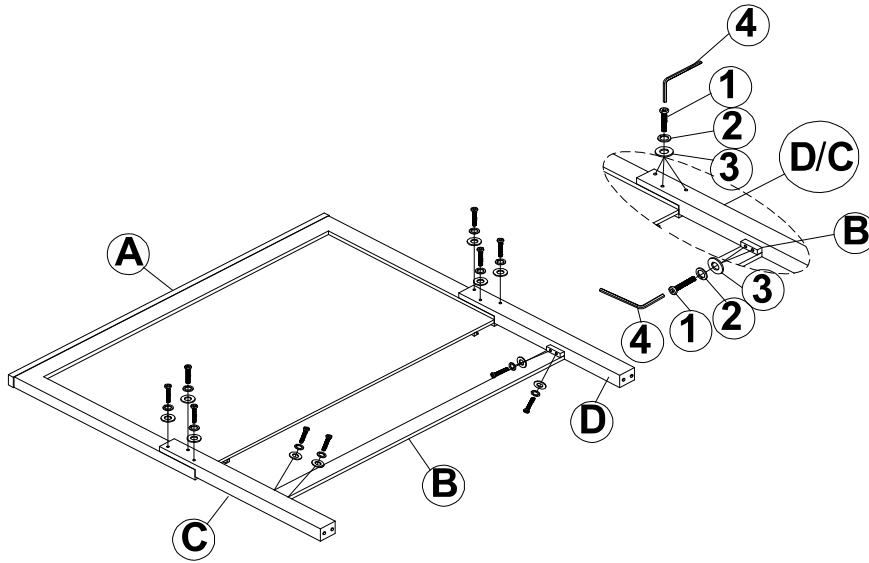

STEP 2

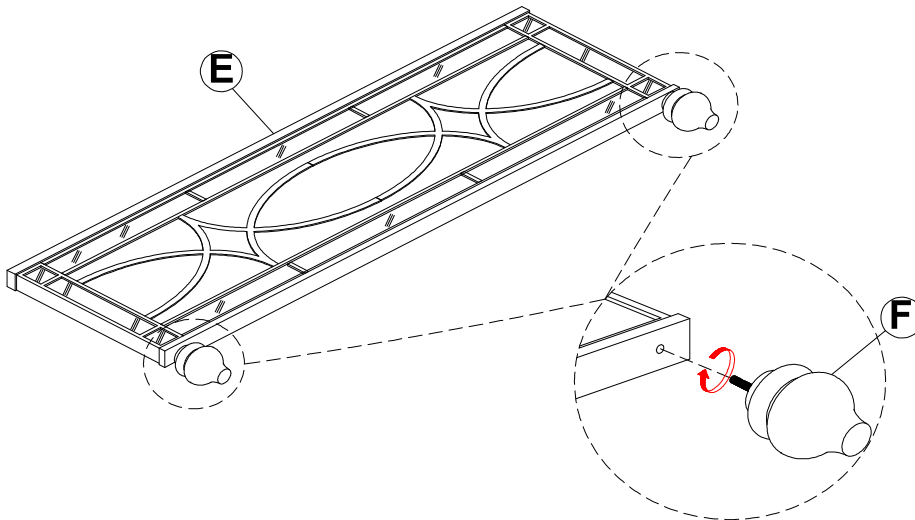

STEP 3

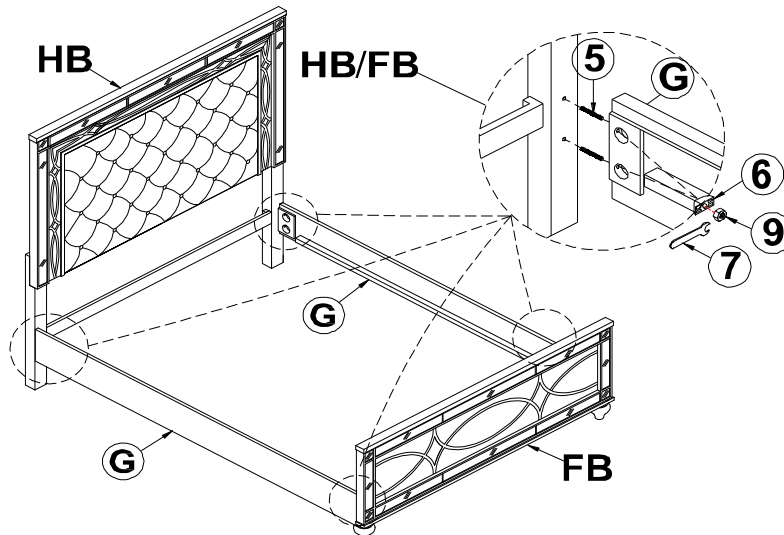

ITEM: **223211KW (B1-B3)**



ASSEMBLY INSTRUCTIONS

STEP 4

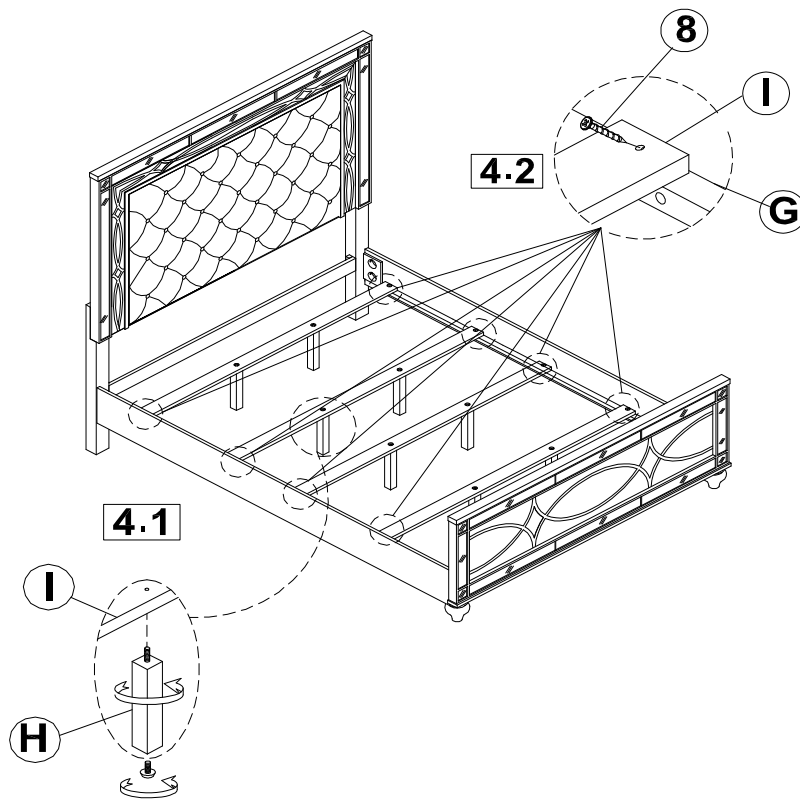

STEP 5
COMPLETE

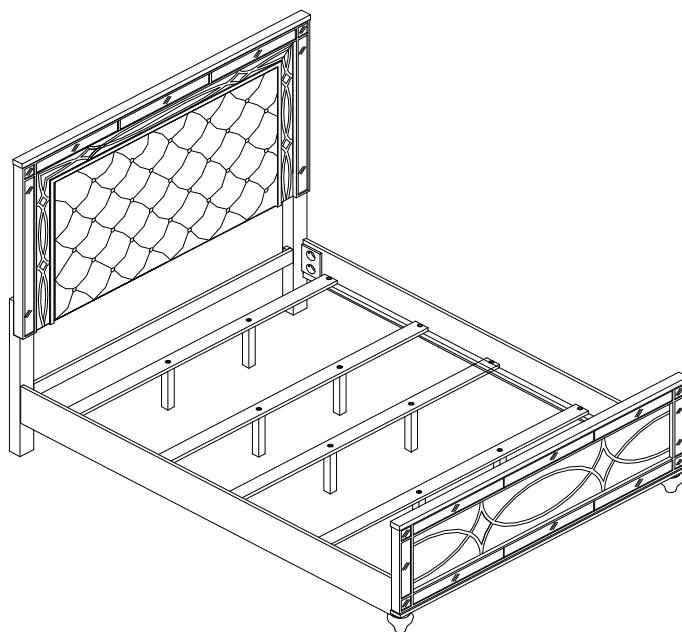

ITEM: **223211KW (B1-B3)**



Inner Size: 73.00"W X 85.50"D

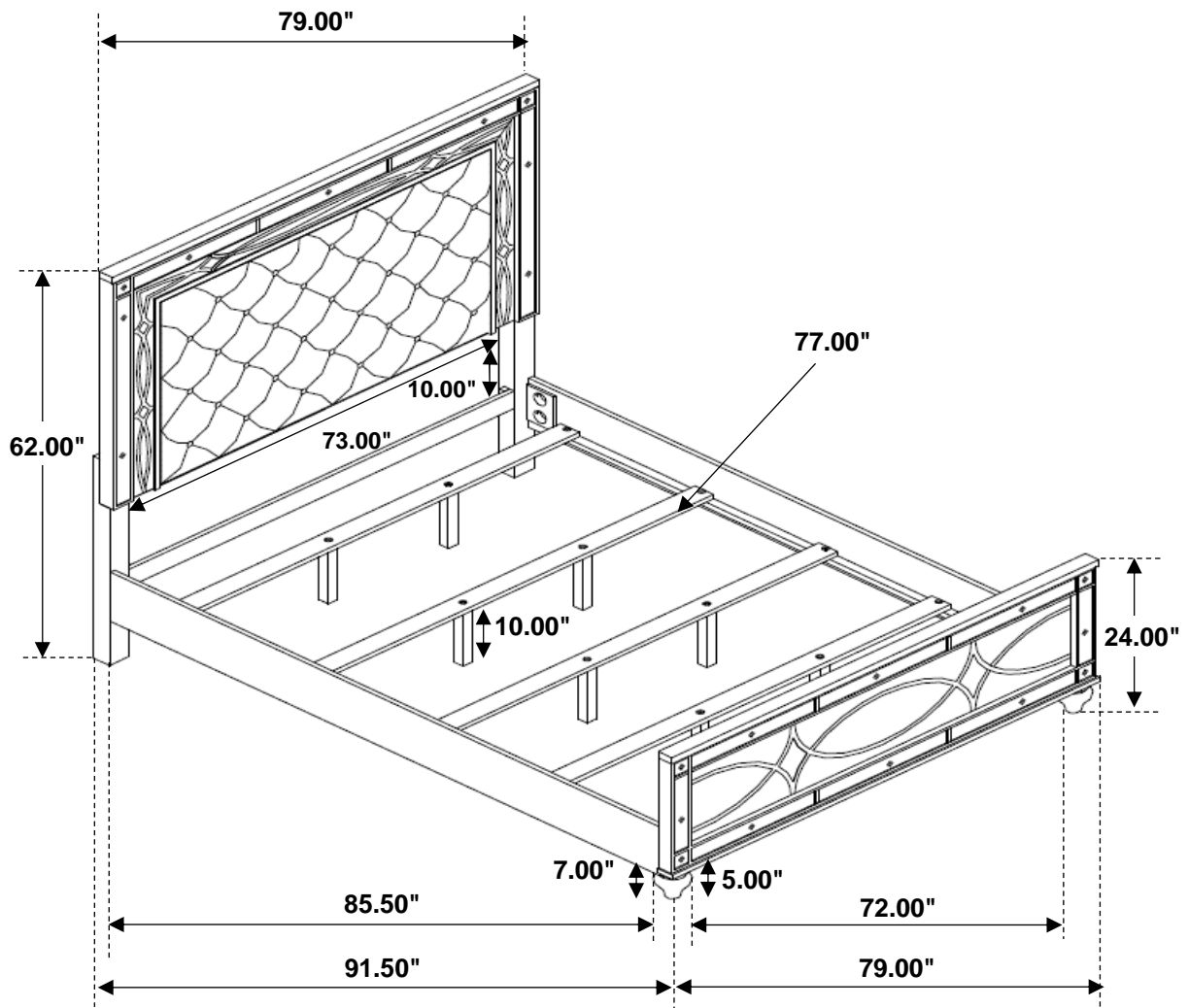

Note: Dimension tolerance $\pm 5\%$