

**ASSEMBLY INSTRUCTIONS**  
**COASTER FINE FURNITURE**

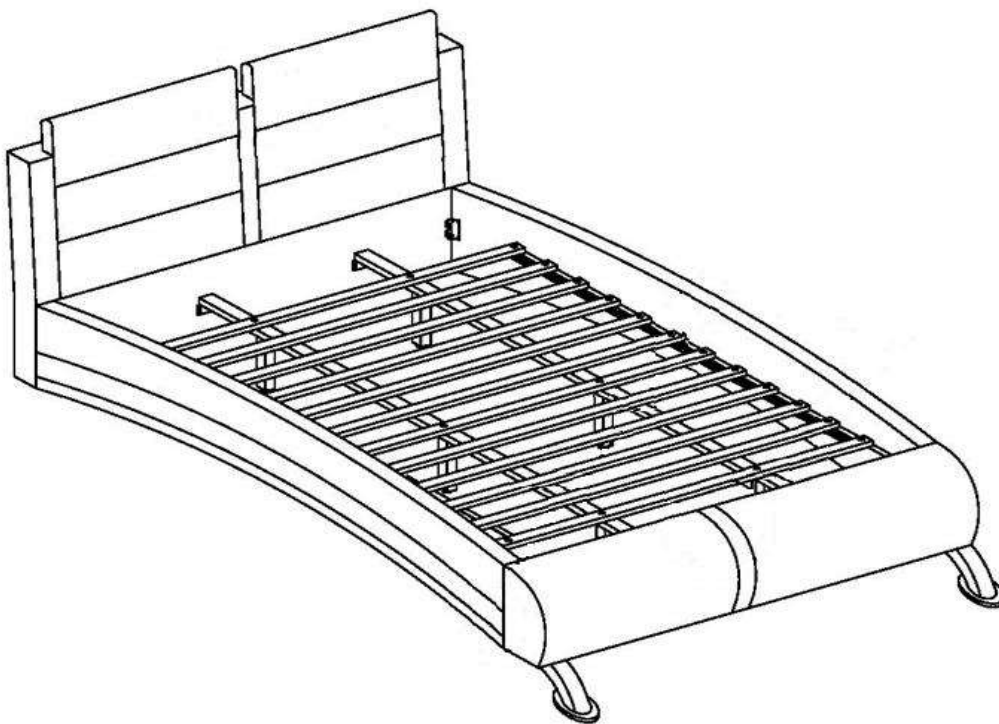

*Fine Furniture for every stage of life*

**300345KW (B1-B3)**  
**California King Bed**

REVISION 0 : 08/13/2014  
REVISION 1 : 05/14/2015  
REVISION 2 : 07/25/2019

# ITEM: 300345KW (B1-B3)



## ASSEMBLY INSTRUCTIONS

### ASSEMBLY TIPS:

1. Remove hardware from box and sort by size.
2. Please check to see that all hardware and parts are present prior to start of assembly.
3. Please follow attached instructions in the same sequence as numbered to assure fast & easy assembly.



### WARNING!

1. Don't attempt to repair or modify parts that are broken or defective. Please contact the store immediately.
2. This product is for home use only and not intended for commercial establishments.



ASSEMBLY TIME

20 MINUTES

## PARTS IDENTIFICATION

### B1 ( BOX 1 )

AN HEADBOARD

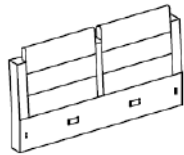

1PC

BN

ROLL SLAT  
(14PCS)

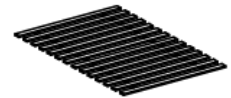

1SET

### B2 ( BOX 2 )

CN FOOTBOARD PANEL

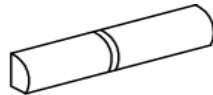

1PC

### B3 ( BOX 3 )

DN LEFT BED RAIL



1PC

IN

CENTER RAIL



2PCS

EN RIGHT BED RAIL



1PC

AN

300345KW (B1)  
FROM BOX 1  
HEADBOARD

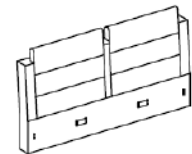

1PC

FN FOOTBOARD LEG



2PCS

300345KW (B2&B3)  
FROM BOX 2 & BOX 3  
FOOTBOARD  
COMPLETE

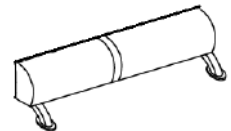

1PC

GN BED SLAT SUPPORT  
WITH LEVELER

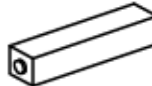

6PCS

HN FOOTBOARD  
SUPPORT WITH  
LEVELER



2PCS

## HARDWARE IDENTIFICATION

### Z-B3 (BOX 3) - HARDWARE PACK IS LOCATED IN 300345KW (B3)

1 SHORT FLAT HEAD  
SCREW

(4 x 25mm - RBW)



14PCS

2 LONG FLAT HEAD  
SCREW

(4 x 32mm - RBW)



34PCS

3 BOLT  
(6x 40mm - RBW)

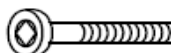

6PCS

4 SMALL ALLEN  
WRENCH

(4 X 65MM - BLK)

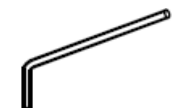

1PC

5 BIG ALLEN WRENCH  
(5 X 70MM - BLK)

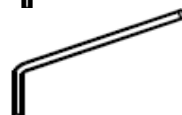

1PC

### NOTE:

Phillips head screw driver is required in the assembly process; however, manufacturer does not provide this item.

# ITEM: 300345KW (B1-B3)

## ASSEMBLY INSTRUCTIONS

### STEP 1

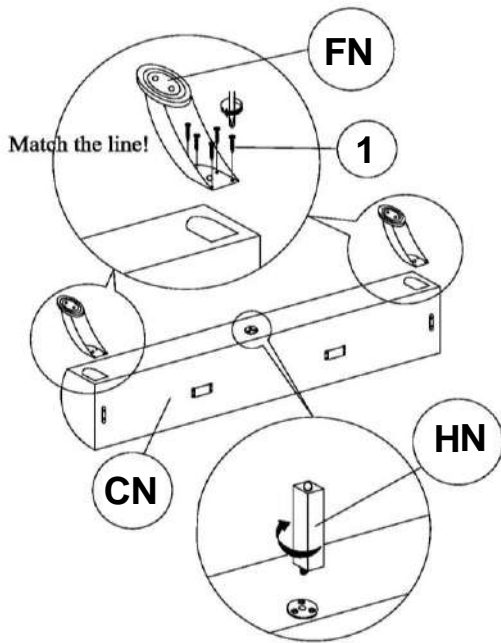

### STEP 2

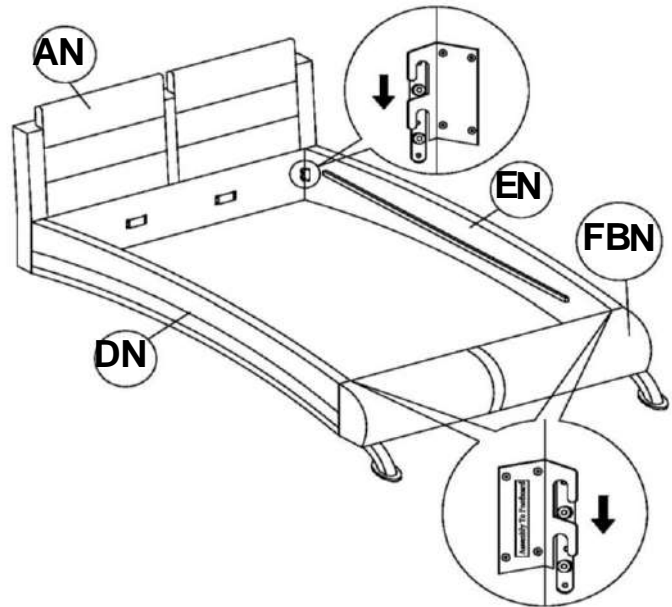

### STEP 3

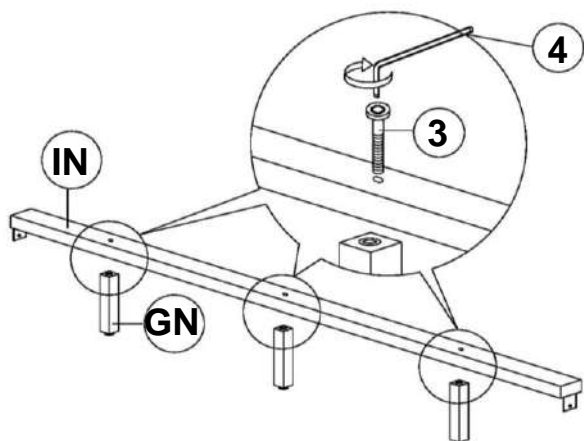

### STEP 4

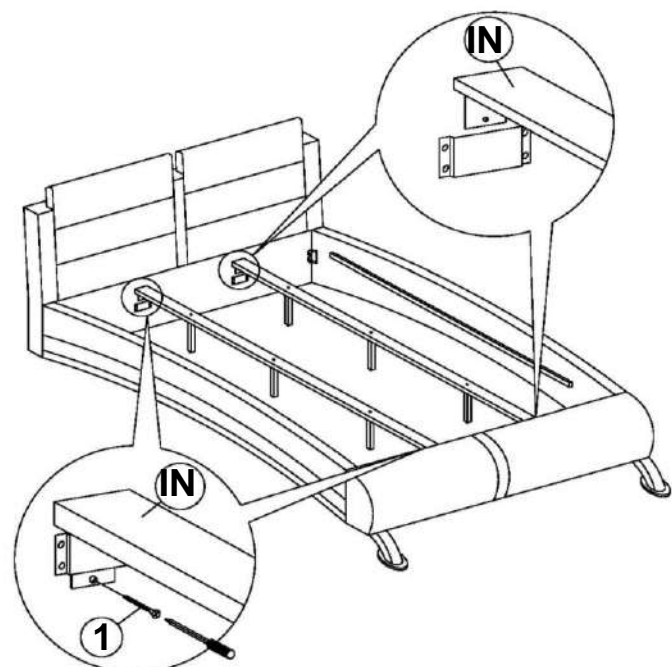

ITEM: **300345KW (B1-B3)**



**ASSEMBLY INSTRUCTIONS**

**STEP 5**

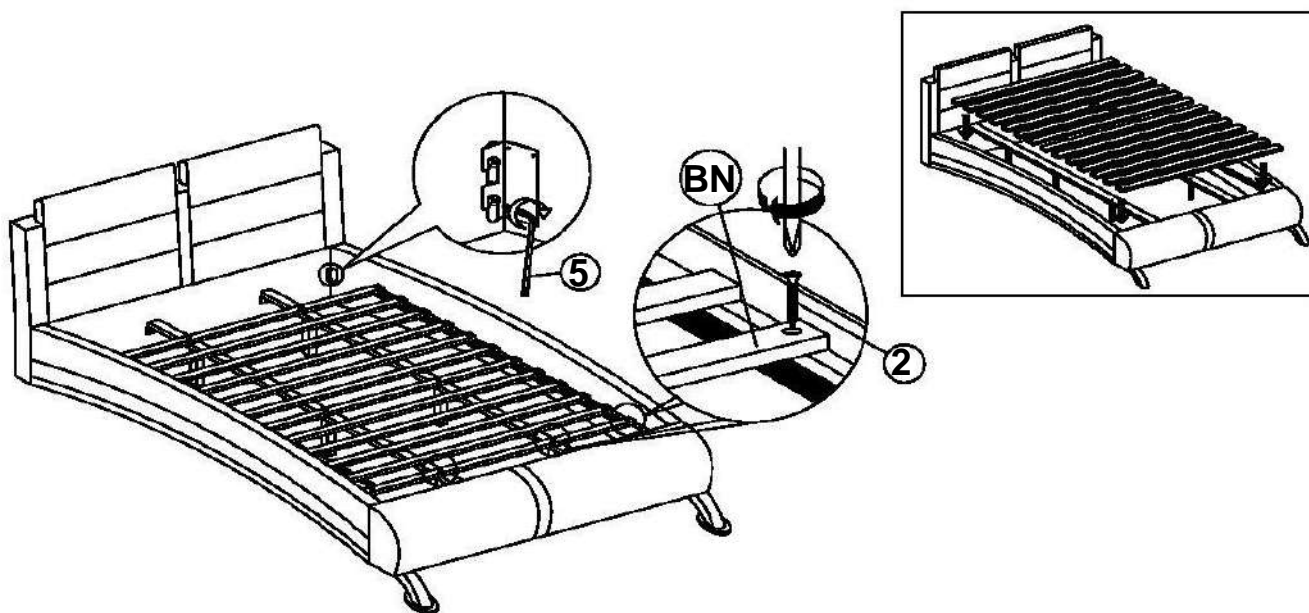

**STEP 6**  
**COMPLETE**

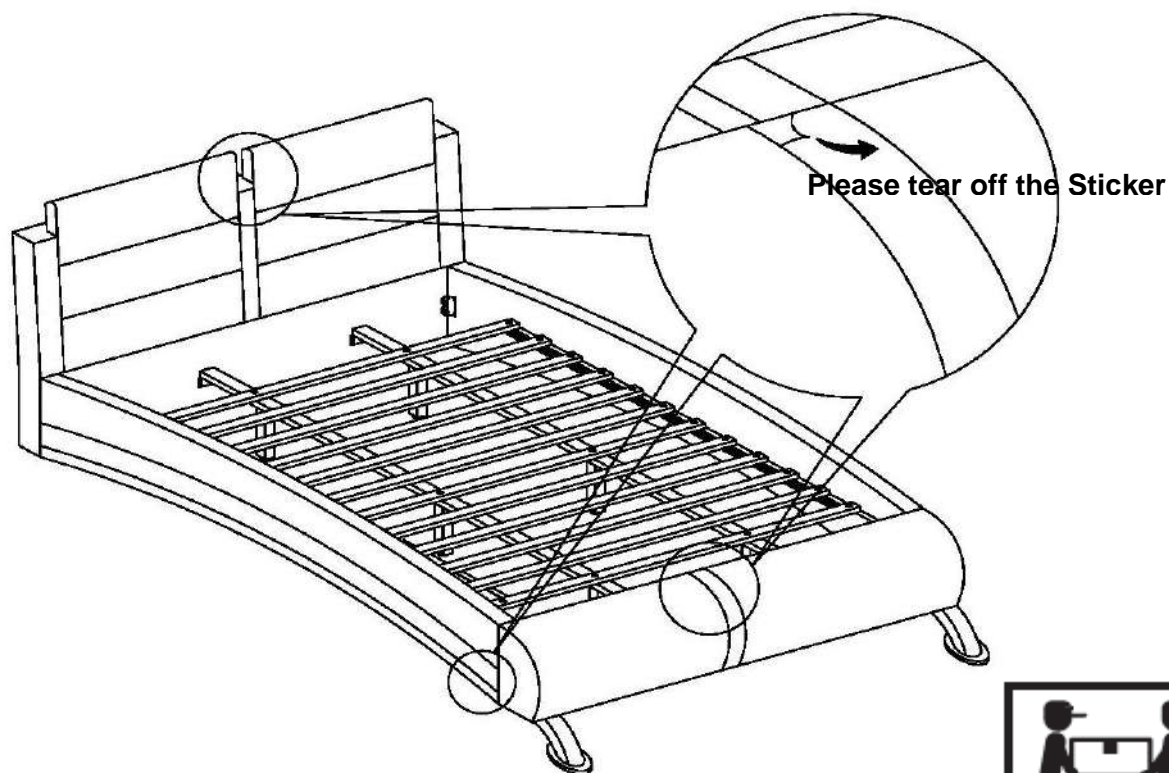

ITEM: **300345KW (B1-B3)**



Inner Size: 72.75"W X 86.00"D

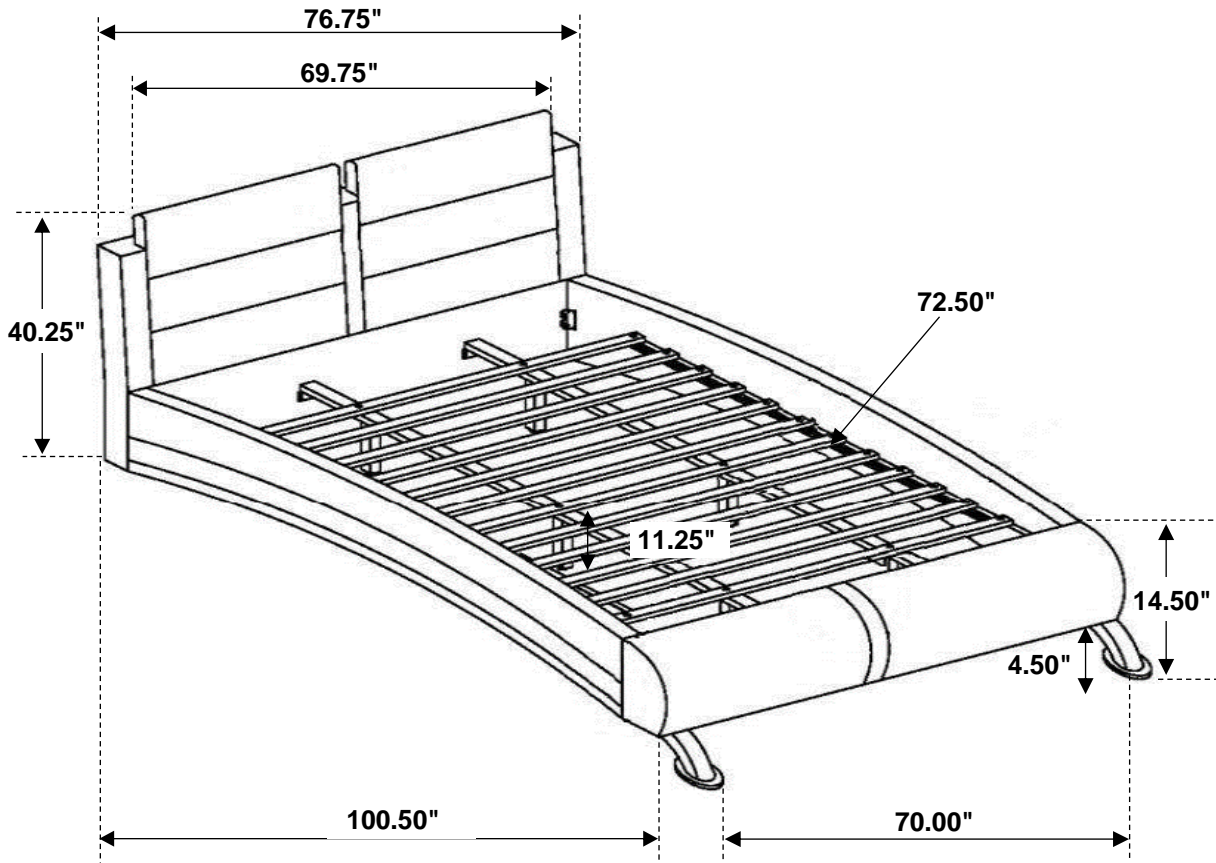

Note: Dimension tolerance  $\pm 5\%$