

**ASSEMBLY INSTRUCTIONS**  
**COASTER FINE FURNITURE**

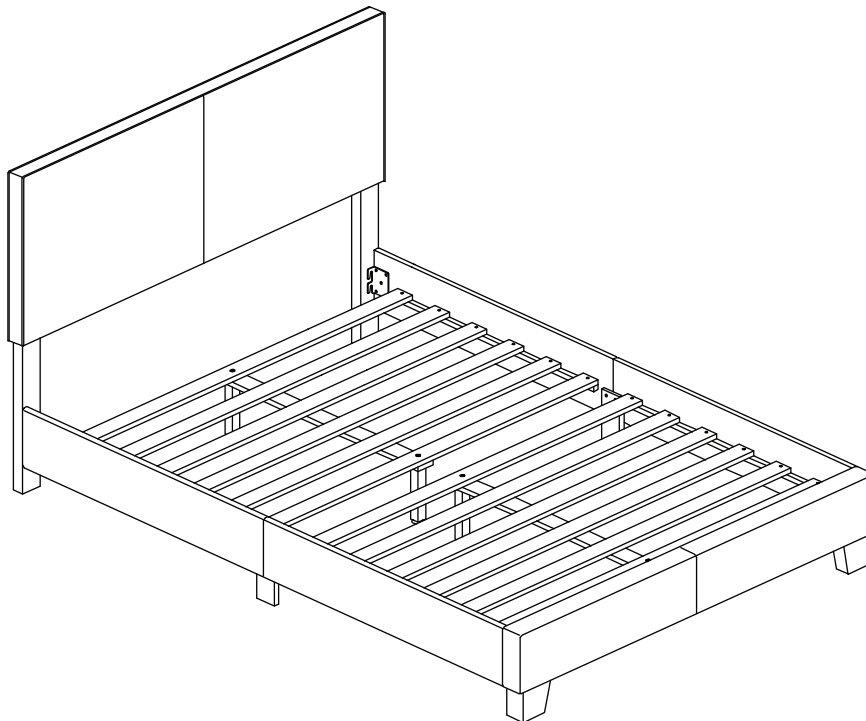

*Fine Furniture for every stage of life*

**300559F**  
**Full Bed**

ITEM: **300559F**



## ASSEMBLY INSTRUCTIONS

### ASSEMBLY TIPS:

1. Remove hardware from box and sort by size.
2. Please check to see that all hardware and parts are present prior to start of assembly.
3. Please follow attached instructions in the same sequence as numbered to assure fast & easy assembly.



### WARNING!











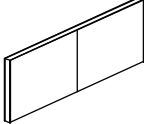

1. Don't attempt to repair or modify parts that are broken or defective. Please contact the store immediately.
2. This product is for home use only and not intended for commercial establishments.

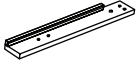

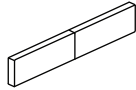
ASSEMBLY TIME

20 MINUTES

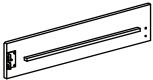
## PARTS IDENTIFICATION

A	HEADBOARD PANEL		1PC	G	BED RAIL (WITH "G" LABEL)		2PCS
B	LEFT HEADBOARD LEG (WITH "L" LABEL)		1PC	H	BED RAIL SUPPORT LEG		2PCS
C	RIGHT HEADBOARD LEG (WITH "R" LABEL)		1PC	I	BED SLAT WITH CENTER HOLE		4PCS
D	FOOTBOARD PANEL		1PC	J	BED SLAT		8PCS
E	FOOTBOARD LEG		2PCS	K	CENTER RAIL		2PCS
F	BED RAIL (WITH "F" LABEL)		2PCS	L	BED SLAT SUPPORT WITH LEVELER		4PCS

### NOTE:

Phillips head screw driver is required in the assembly process; however, manufacturer does not provided this item.

## ASSEMBLY INSTRUCTIONS

### ASSEMBLY TIPS:











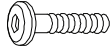

1. Remove hardware from box and sort by size.
2. Please check to see that all hardware and parts are present prior to start of assembly.
3. Please follow attached instructions in the same sequence as numbered to assure fast & easy assembly.

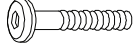

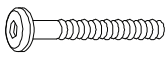
### WARNING!

1. Don't attempt to repair or modify parts that are broken or defective. Please contact the store immediately.
2. This product is for home use only and not intended for commercial establishments.

## HARDWARE IDENTIFICATION

1	<b>BOLT 1</b> (M8 x 20mm - RBW)		8PCS	7	<b>LOCK WASHER</b> (1/4" X 12 Ø - RBW)		14PCS
2	<b>BOLT 2</b> (M6 x 25mm - RBW)		8PCS	8	<b>SMALL FLAT WASHER</b> (1/4" X 13 Ø - RBW)		14PCS
3	<b>BOLT 3</b> (M6 x 35mm - RBW)		6PCS	9	<b>BIG FLAT WASHER</b> (1/4" X 19 Ø - RBW)		8PCS
4	<b>BOLT 4</b> (M6 x 50mm - RBW)		4PCS	10	<b>FLAT HEAD SCREW</b> (M4 x 32mm - RBW)		24PCS
5	<b>BOLT 5</b> (M6 x 70mm - RBW)		2PCS	11	<b>SMALL ALLEN WRENCH</b> (M4 x 100mm - BLK)		1PC
6	<b>WOOD DOWEL</b> (M8Ø x 30mm)		2PCS	12	<b>BIG ALLEN WRENCH</b> (M5 x 65mm - BLK)		1PC

### NOTE:

Phillips head screw driver is required in the assembly process; however, manufacturer does not provided this item.

ITEM: **300559F**

**ASSEMBLY INSTRUCTIONS**

**STEP 1**

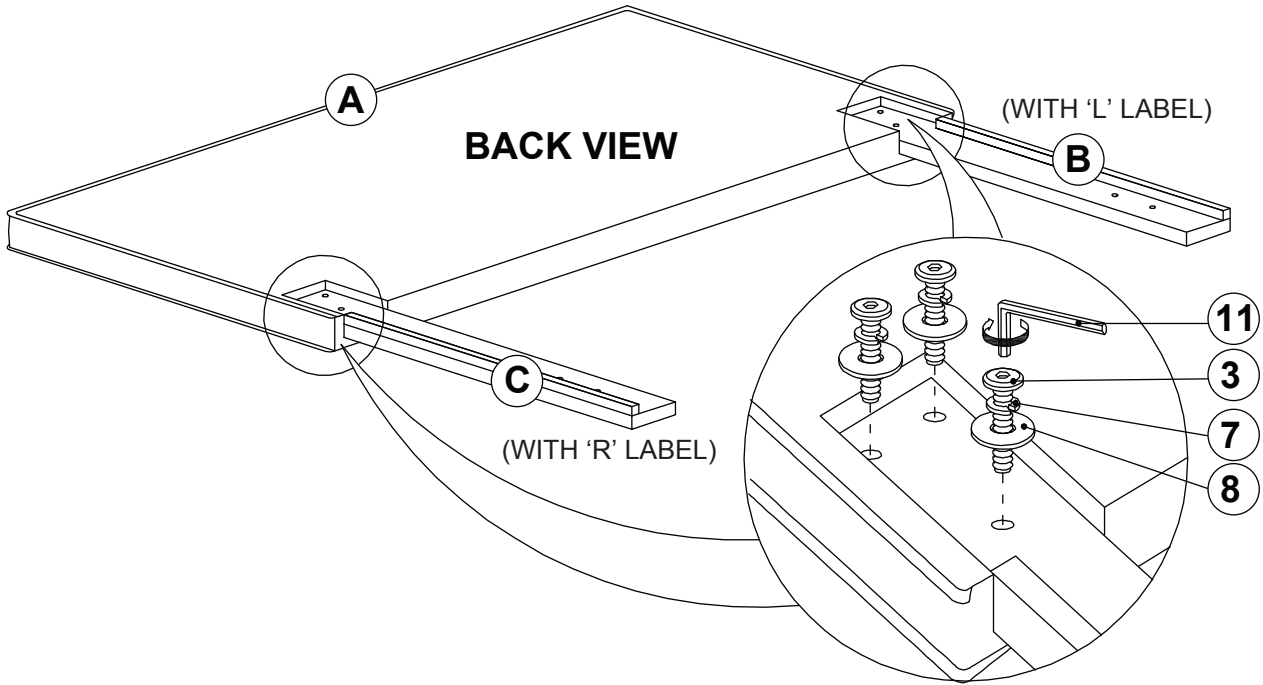

**STEP 2**

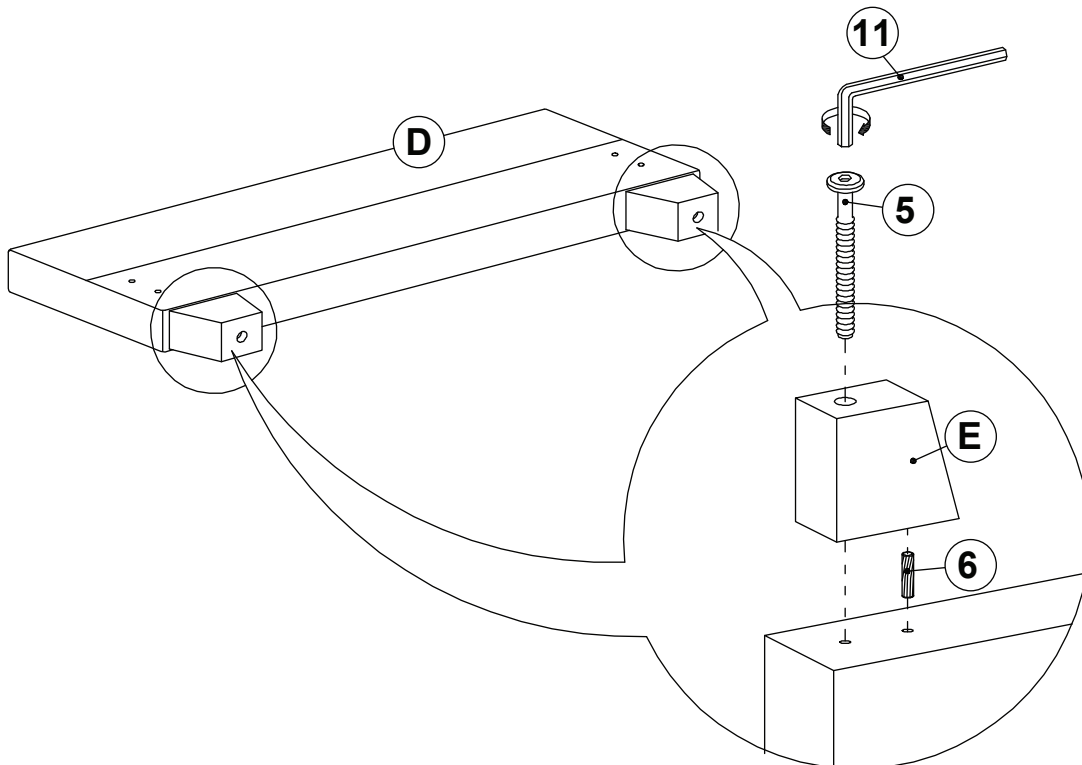

ITEM: **300559F**

**ASSEMBLY INSTRUCTIONS**

**STEP 3**

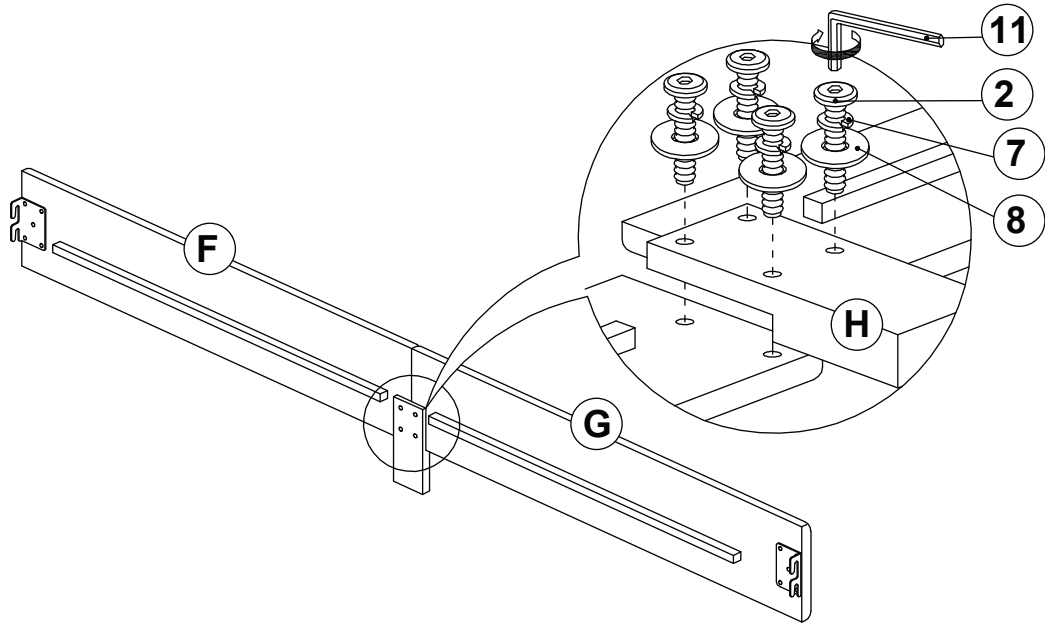

**STEP 4**

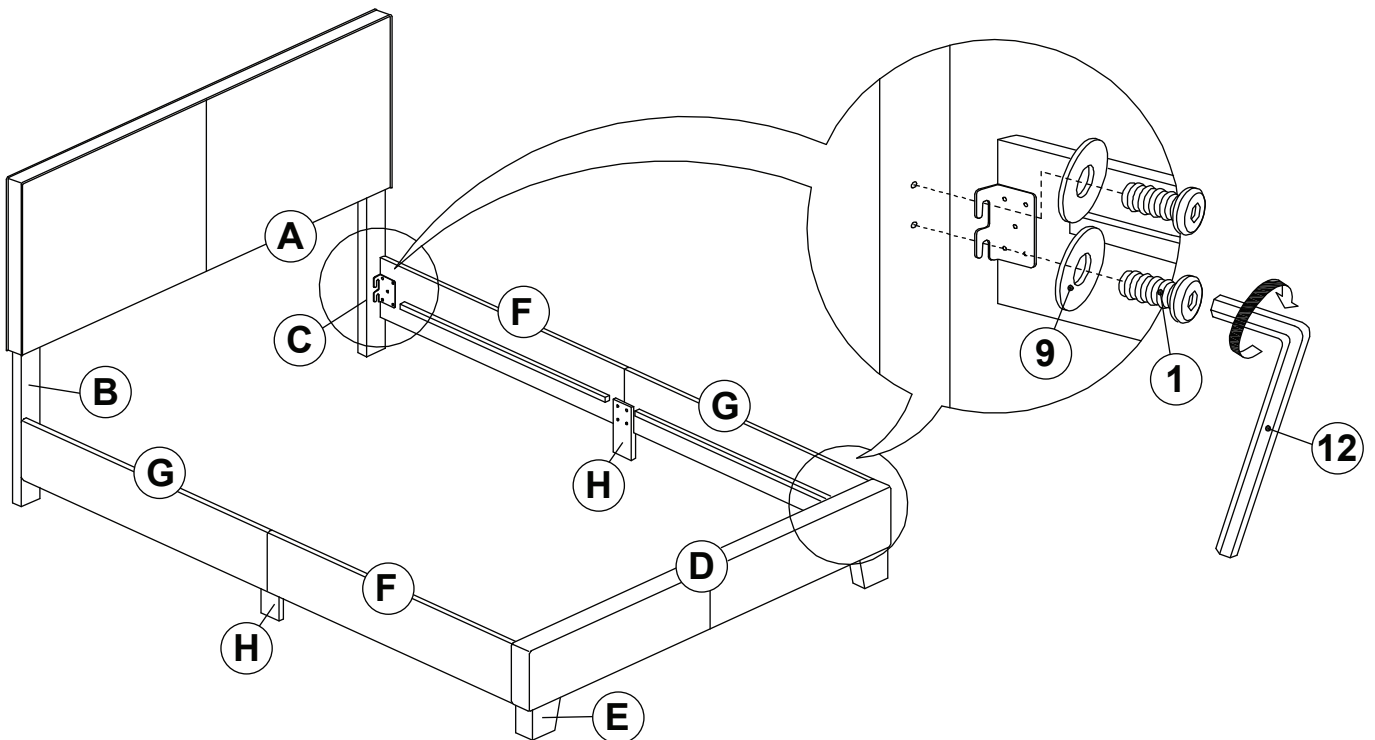

ITEM: **300559F**

**ASSEMBLY INSTRUCTIONS**

**STEP 5**

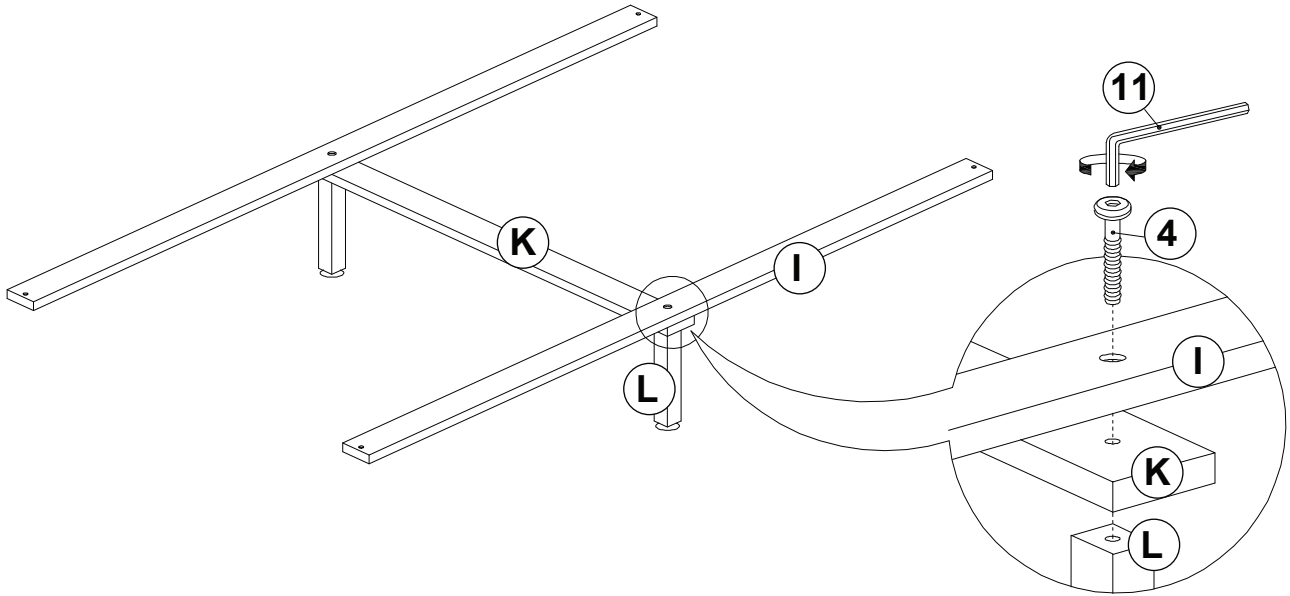

**STEP 6**

**COMPLETE**

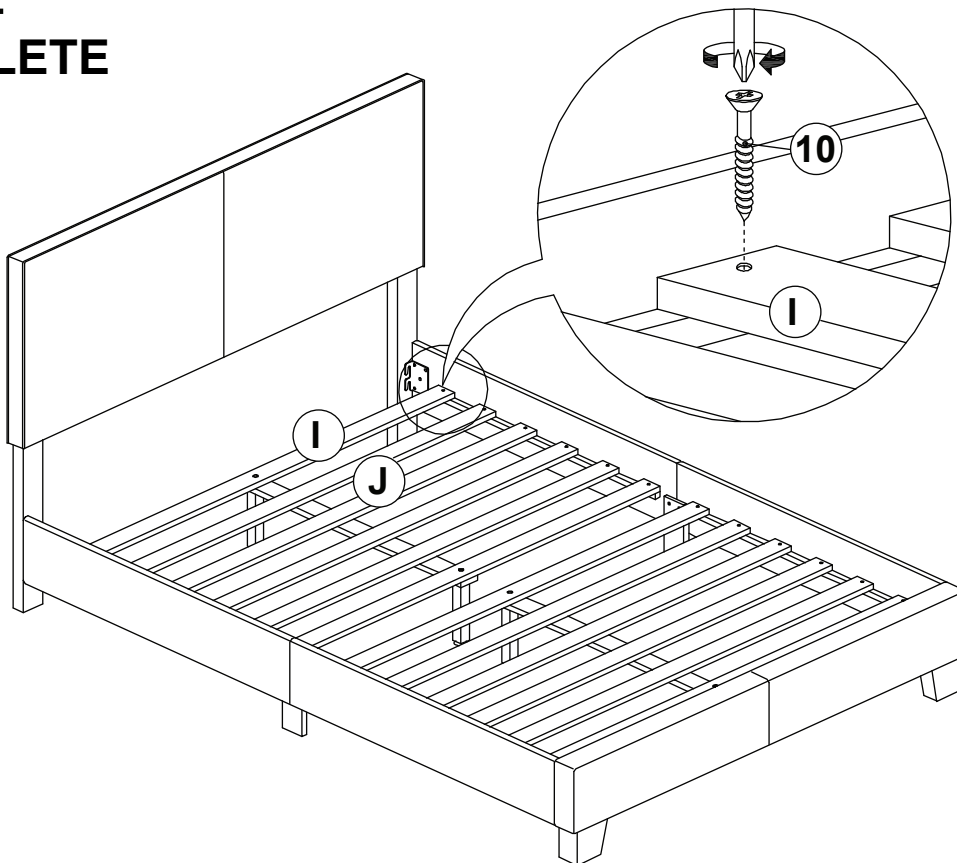

ITEM: **300559F**



Inner size: 54.50"W X 76.00"D

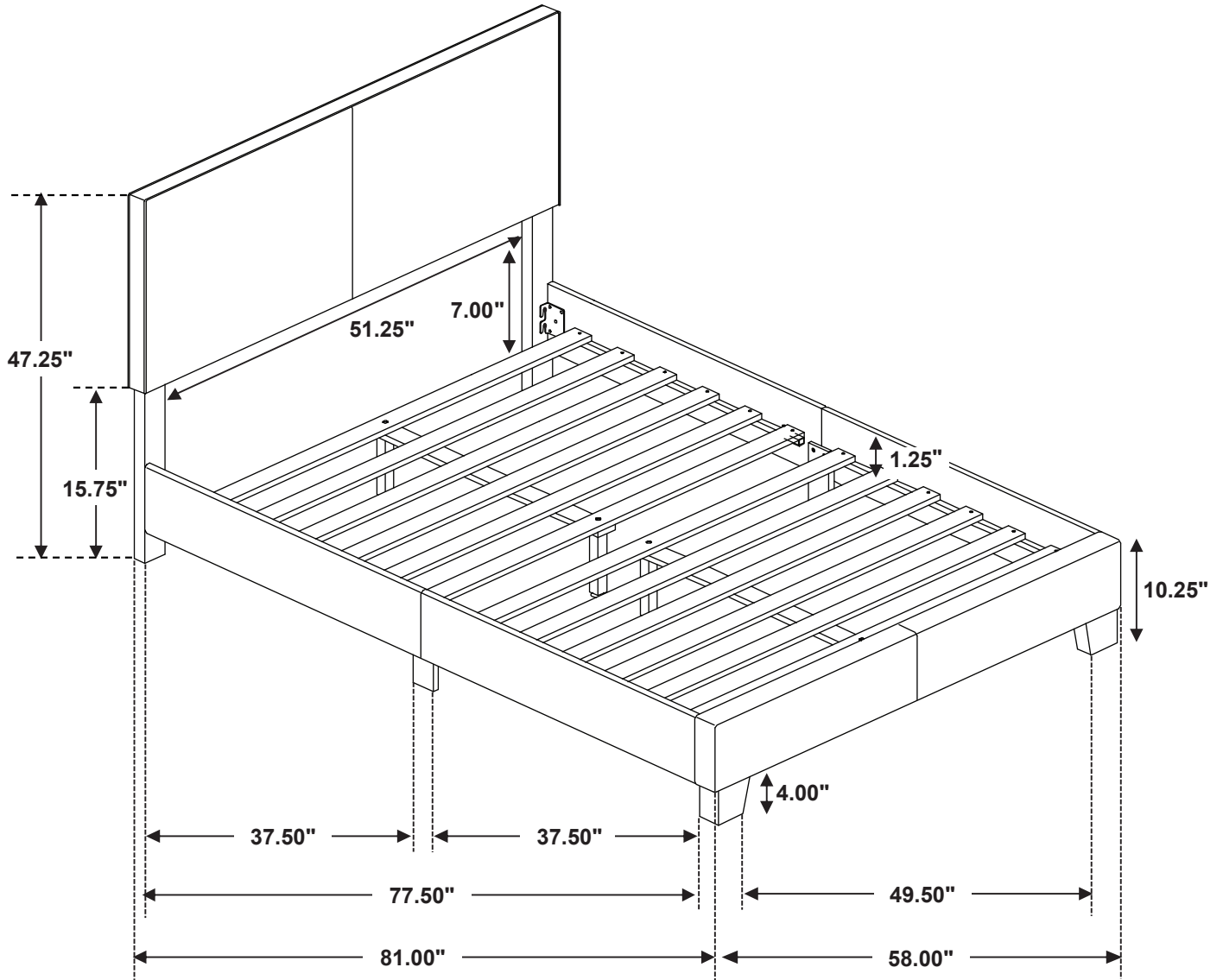

Note: Dimension tolerance  $\pm 5\%$