

ASSEMBLY INSTRUCTIONS
COASTER FINE FURNITURE



Fine Furniture for every stage of life

224491KE(B1-B3)
Eastern King Bed

ITEM: 224491KE (B1-B3)



ASSEMBLY INSTRUCTIONS

ASSEMBLY TIPS:

1. Remove hardware from box and sort by size.
2. Please check to see that all hardware and parts are present prior to start of assembly.
3. Please follow attached instructions in the same sequence as numbered to assure fast & easy assembly.



WARNING!

1. Don't attempt to repair or modify parts that are broken or defective. Please contact the store immediately.
2. This product is for home use only and not intended for commercial establishments.



ASSEMBLY TIME

30 MINUTES

PARTS IDENTIFICATION

B1 (BOX 1)

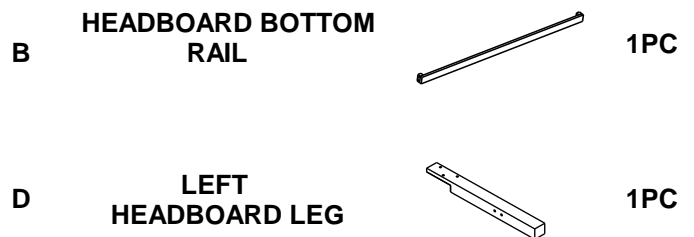
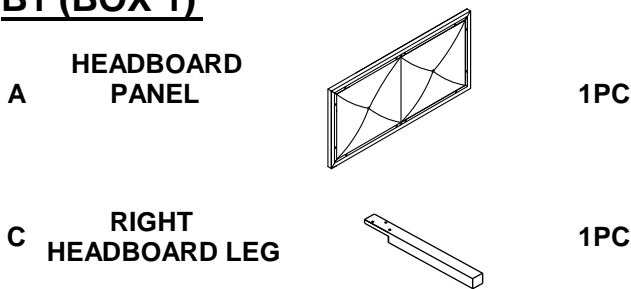

B2 (BOX 2)

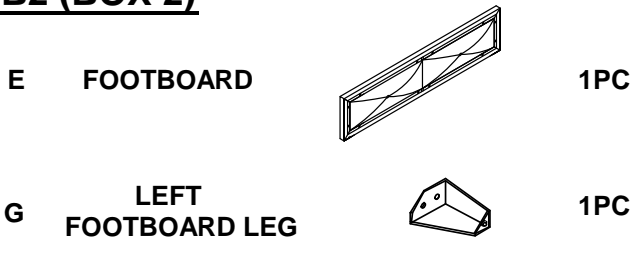

B3 (BOX 3)

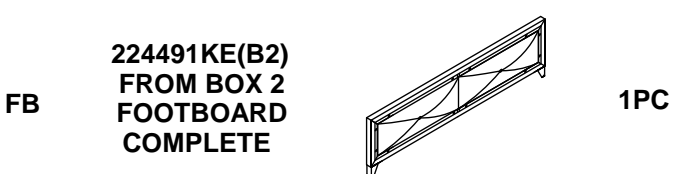
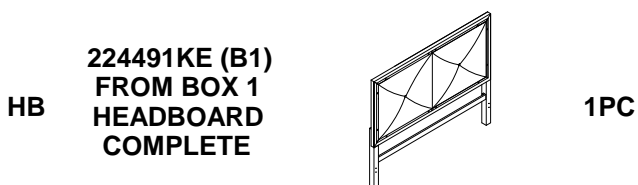
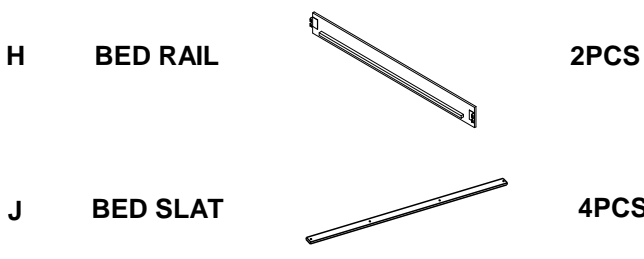

NOTE:

Phillips head screw driver is required in the assembly process; however, manufacturer does not provide this item.

ITEM: 224491KE (B1-B3)

ASSEMBLY INSTRUCTIONS

ASSEMBLY TIPS:

1. Remove hardware from box and sort by size.
2. Please check to see that all hardware and parts are present prior to start of assembly.
3. Please follow attached instructions in the same sequence as numbered to assure fast & easy assembly.





WARNING!







1. Don't attempt to repair or modify parts that are broken or defective. Please contact the store immediately.
2. This product is for home use only and not intended for commercial establishments.

HARDWARE IDENTIFICATION





Z-B1 (BOX 1) - HARDWARE PACK IS LOCATED IN 224491KE (B1)

1	BOLT (ϕ 5/16" x 50MM- RBW)		10PCS	2	LOCK WASHER (ϕ 5/16" - RBW)		10PCS
3	FLAT WASHER (ϕ 5/16" - RBW)		10PCS	4	ALLEN WRENCH (4MM x 59MM - RBW)		1PC

Z-B2 (BOX 2) - HARDWARE PACK IS LOCATED IN 224491KE (B2)

5	BOLT (ϕ 5/16" x 20MM- RBW)		4PCS	6	LOCK WASHER (ϕ 5/16" - RBW)		4PCS
7	FLAT WASHER (ϕ 5/16" - RBW)		4PCS	8	ALLEN WRENCH (4MM x 59MM - RBW)		1PC

Z-B3 (BOX 3) - HARDWARE PACK IS LOCATED IN 224491KE (B3)

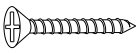
9	BOLT (ϕ 5/16" x 20MM- RBW)		8PCS	10	LOCK WASHER (ϕ 5/16" - RBW)		8PCS
11	FLAT WASHER (ϕ 5/16" - RBW)		8PCS	12	ALLEN WRENCH (4MM x 59MM - RBW)		1PC
13	FLAT HEAD SCREW (ϕ 4 x 30MM - RBW)		8PCS				

NOTE:

Phillips head screw driver is required in the assembly process; however, manufacturer does not provide this item.

ITEM: 224491KE (B1-B3)

ASSEMBLY INSTRUCTIONS

STEP 1

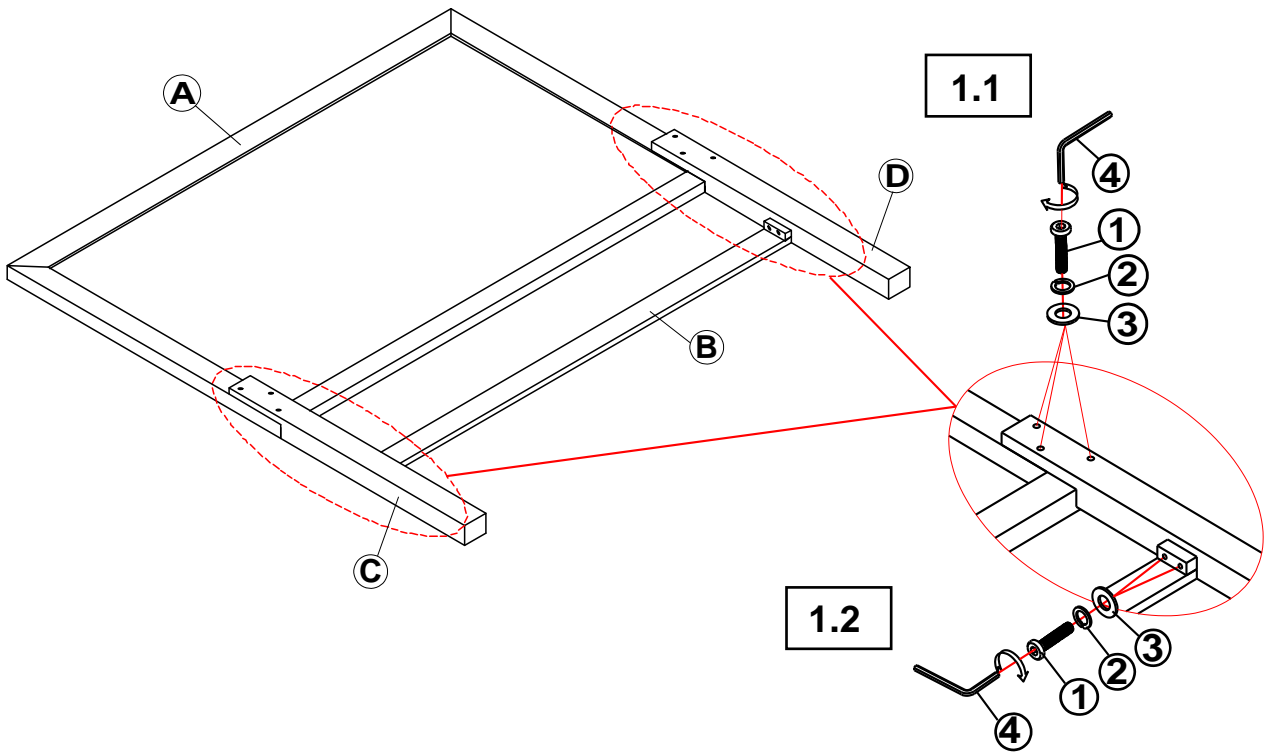

STEP 2

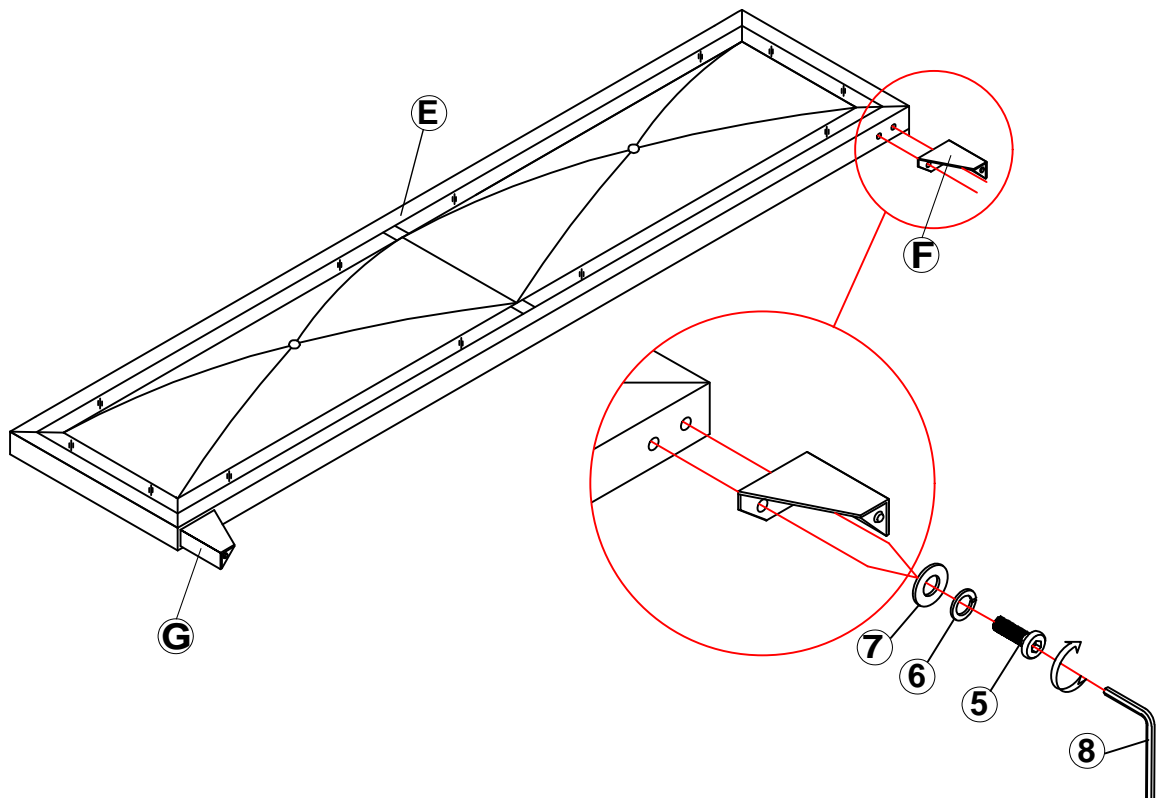

ITEM: 224491KE (B1-B3)

ASSEMBLY INSTRUCTIONS

STEP 3

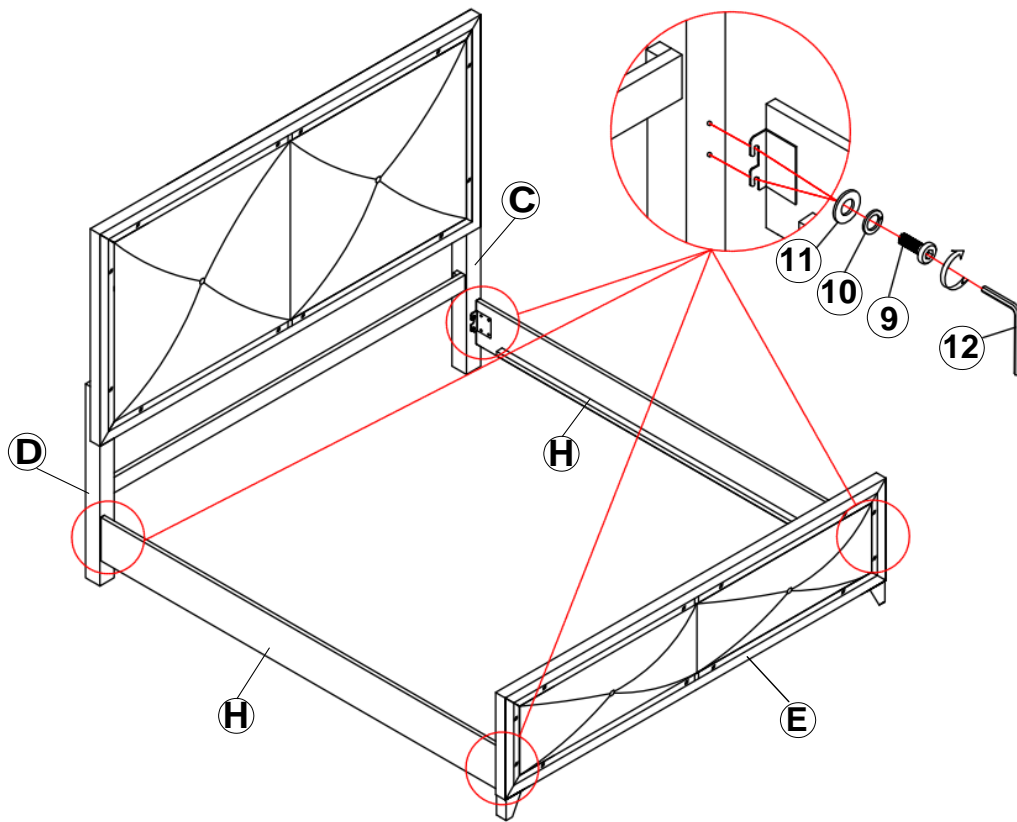

STEP 4

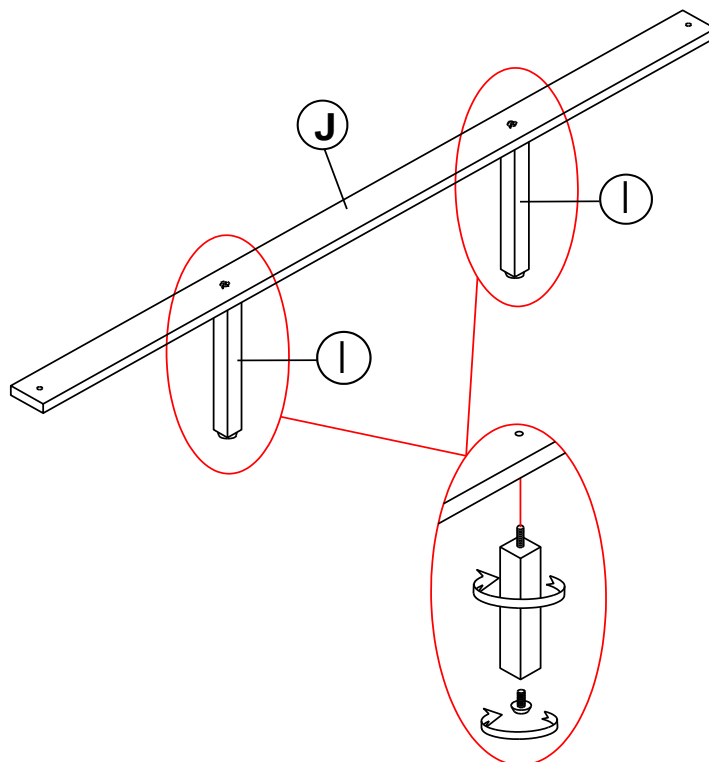

ITEM: **224491KE (B1-B3)**

ASSEMBLY INSTRUCTIONS

STEP 5

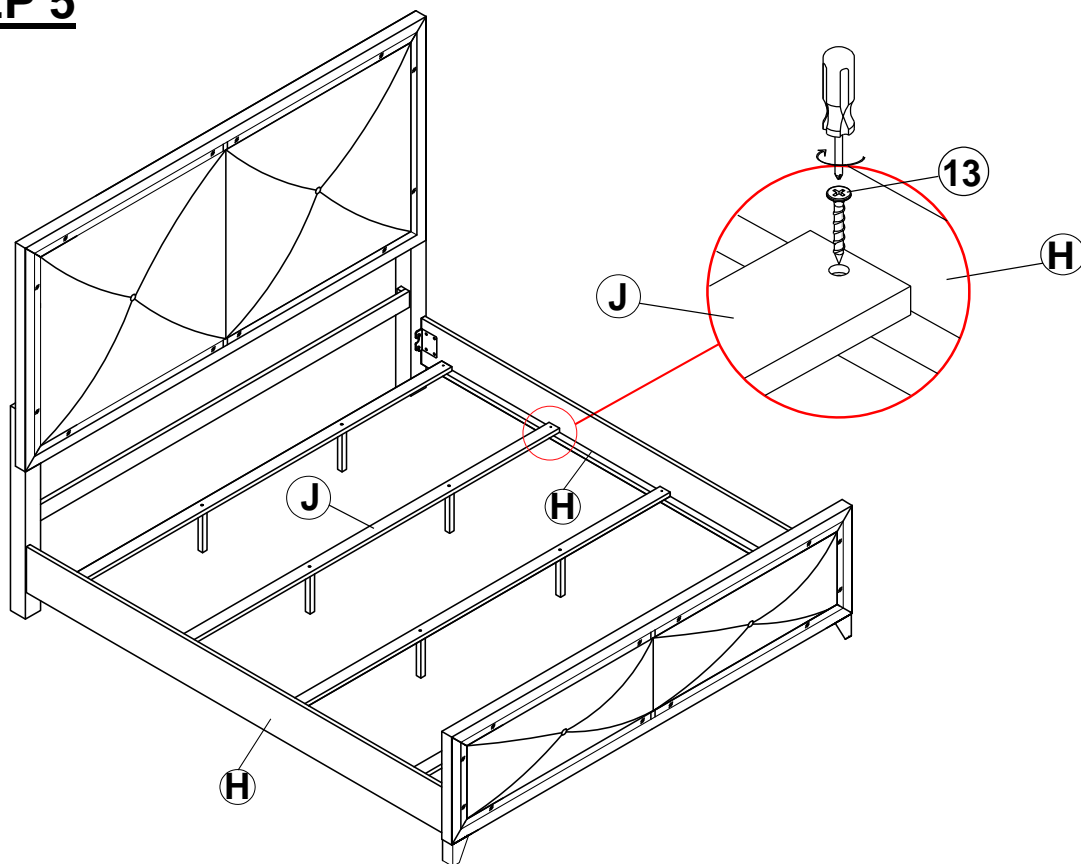

STEP 6
COMPLETE

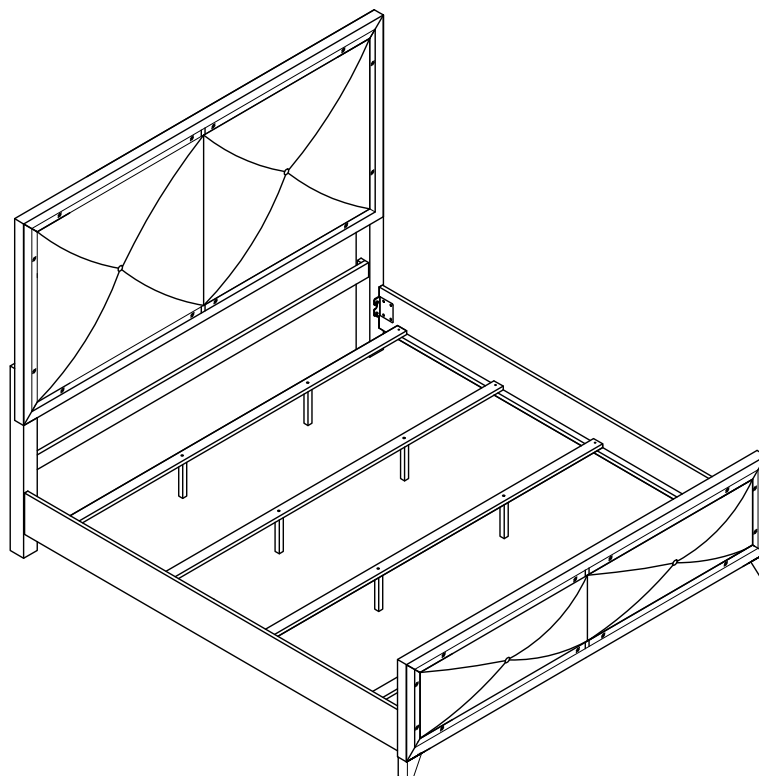

ITEM: 224491KE (B1-B3)



Inner Size : 81.50"W X 77.00"D

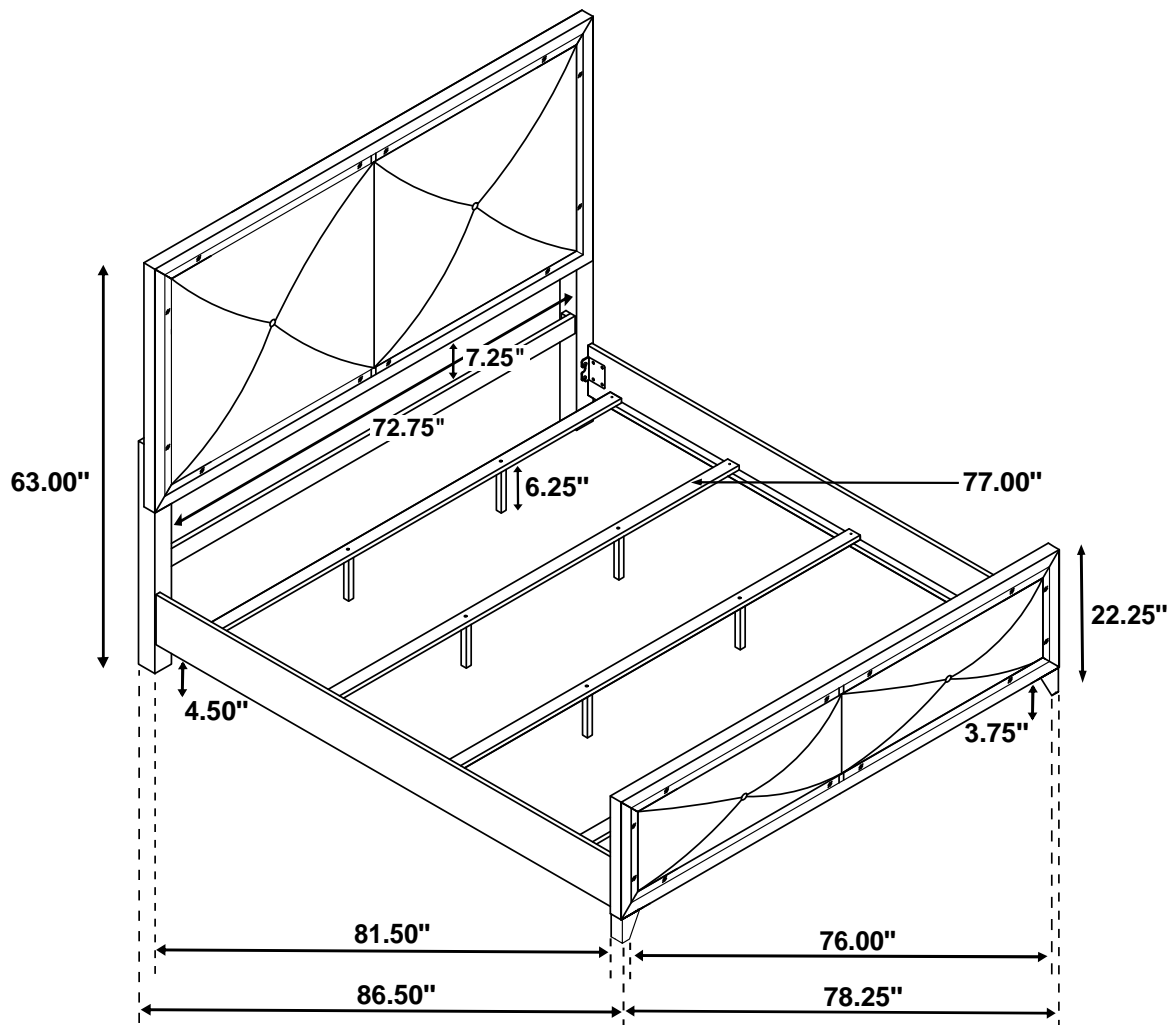

Note: Dimension tolerance $\pm 5\%$