

*ASSEMBLY INSTRUCTIONS*  
*COASTER FINE FURNITURE*



*Fine Furniture for every stage of life*

**107593**  
**Dining Bench**

ITEM: **107593**



## ASSEMBLY INSTRUCTIONS

### ASSEMBLY TIPS:

1. Remove hardware from box and sort by size.
2. Please check to see that all hardware and parts are present prior to start of assembly.
3. Please follow attached instructions in the same sequence as numbered to assure fast & easy assembly.



### WARNING!





1. Don't attempt to repair or modify parts that are broken or defective. Please contact the store immediately.
2. This product is for home use only and not intended for commercial establishments.

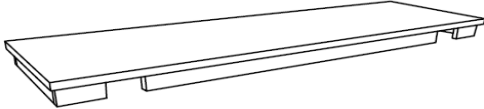

ASSEMBLY TIME

40 MINUTES

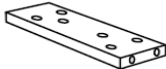
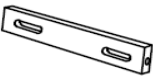
## PARTS IDENTIFICATION

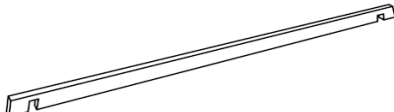
A	SEAT		1PC
B	LEG B		2PCS
C	LEG C		2PCS
D	MOUNTING PLATE		2PCS
E	SUPPORT BAR		2PCS
F	CROSSBAR		2PCS
G	TRESTLE BAR		1PC

ITEM: **107593**

## ASSEMBLY INSTRUCTIONS

### ASSEMBLY TIPS:









1. Remove hardware from box and sort by size.
2. Please check to see that all hardware and parts are present prior to start of assembly.
3. Please follow attached instructions in the same sequence as numbered to assure fast & easy assembly.



### WARNING!

1. Don't attempt to repair or modify parts that are broken or defective. Please contact the store immediately.
2. This product is for home use only and not intended for commercial establishments.

## HARDWARE IDENTIFICATION

1	<b>ALLEN WRENCH</b> (M4 - BLK)		1PC
2	<b>SHORT BOLT</b> (M6 x 35mm - BK)		12PCS
3	<b>MEDIUM BOLT</b> (M6 x 50mm - BK)		4PCS
4	<b>LONG BOLT</b> (M6 x 60mm - BK)		4PCS
5	<b>HALF ROUND NUT</b> (M6 - BLK)		4PCS
6	<b>LOCK WASHER</b> (M6 - BK)		16PCS
7	<b>FLAT WASHER</b> (M6 - BK)		12PCS
8	<b>PLASTIC DOWEL</b> (M8 x 30mm - BLK)		14PCS
9	<b>FLAT HEAD SCREW</b> (M4 x 38mm - RBW)		2PCS

### NOTE:

Phillips head screw driver is required in the assembly process; however, manufacturer does not provide this item.

ITEM: **107593**

**ASSEMBLY INSTRUCTIONS**

**STEP 1**

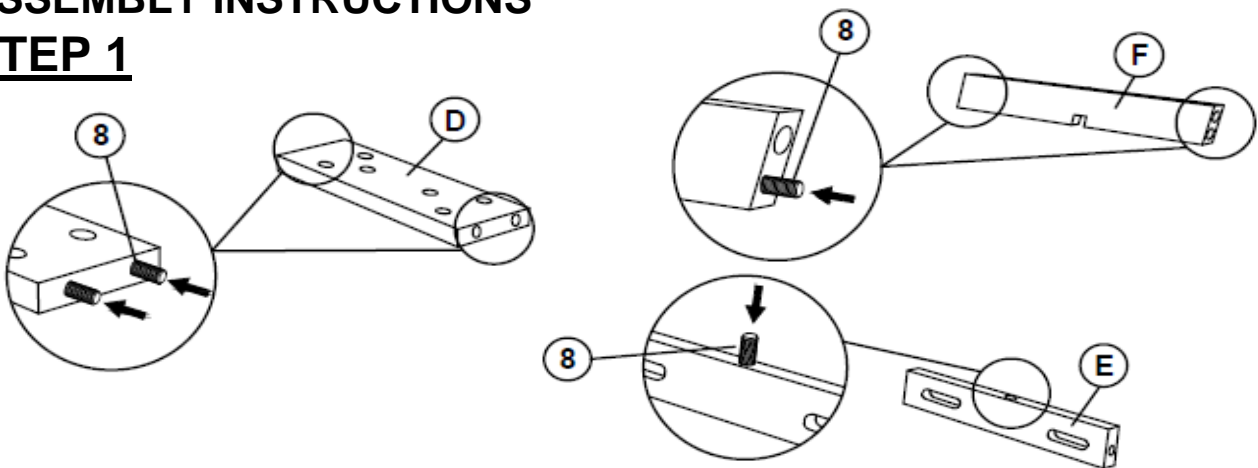

**STEP 2**

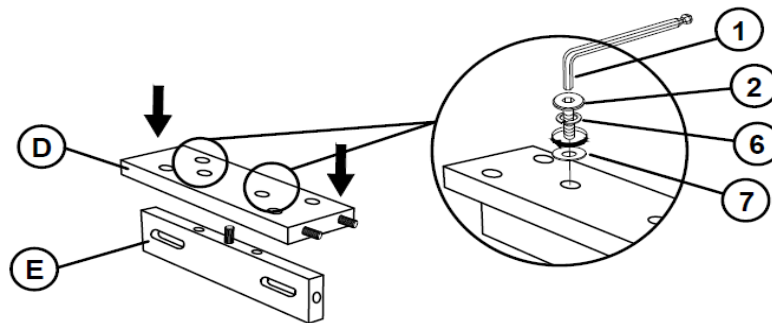

\*\*\* Do not fully tighten the bolt

**STEP 3**

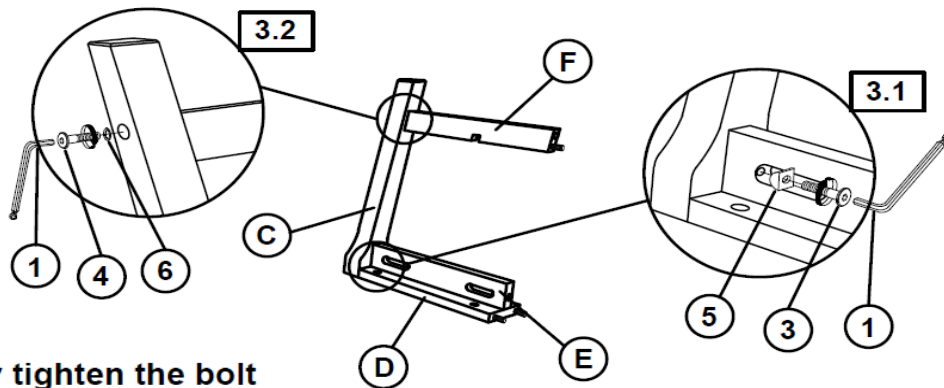

\*\*\* Do not fully tighten the bolt

**STEP 4**

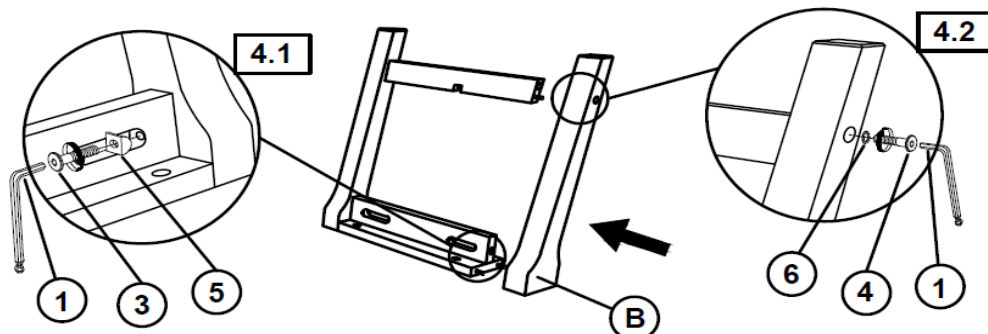

\*\*\* Please fully tighten all the bolts

ITEM: **107593**

**ASSEMBLY INSTRUCTIONS**

**STEP 5**

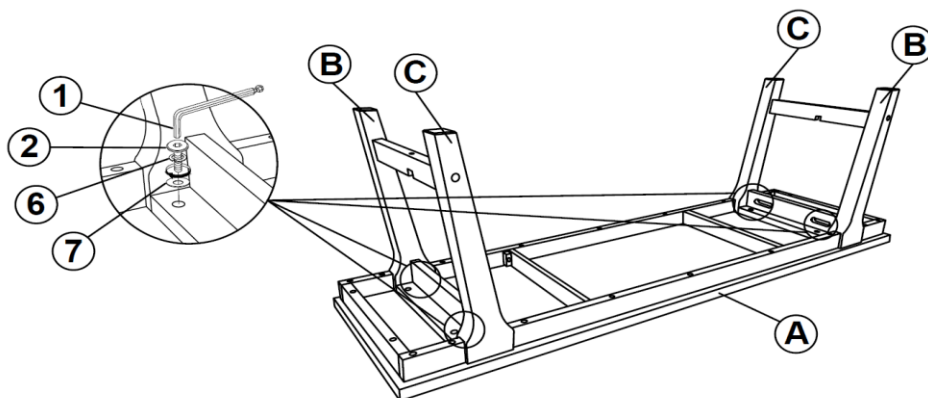

\*\*\* Do not fully tighten the bolt

**STEP 6**

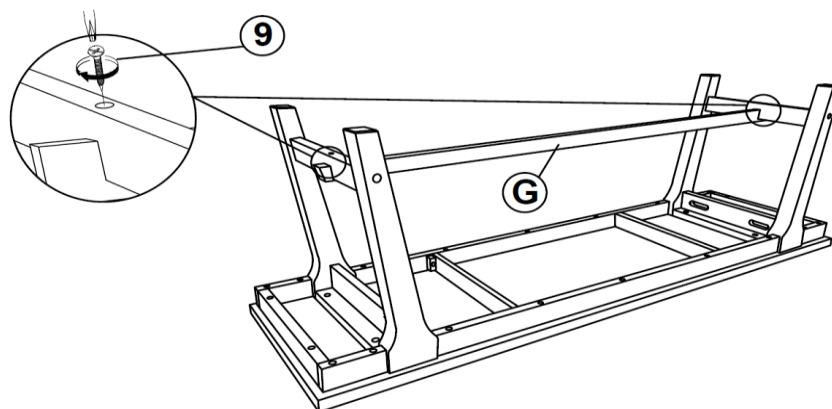

\*\*\* Please fully tighten all the bolts

**STEP 7**  
**COMPLETE**

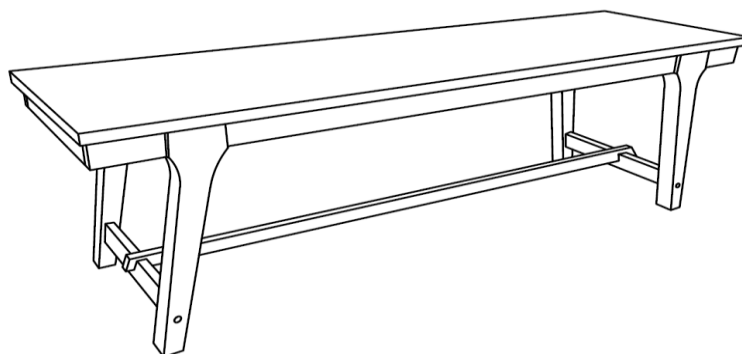

ITEM: **107593**

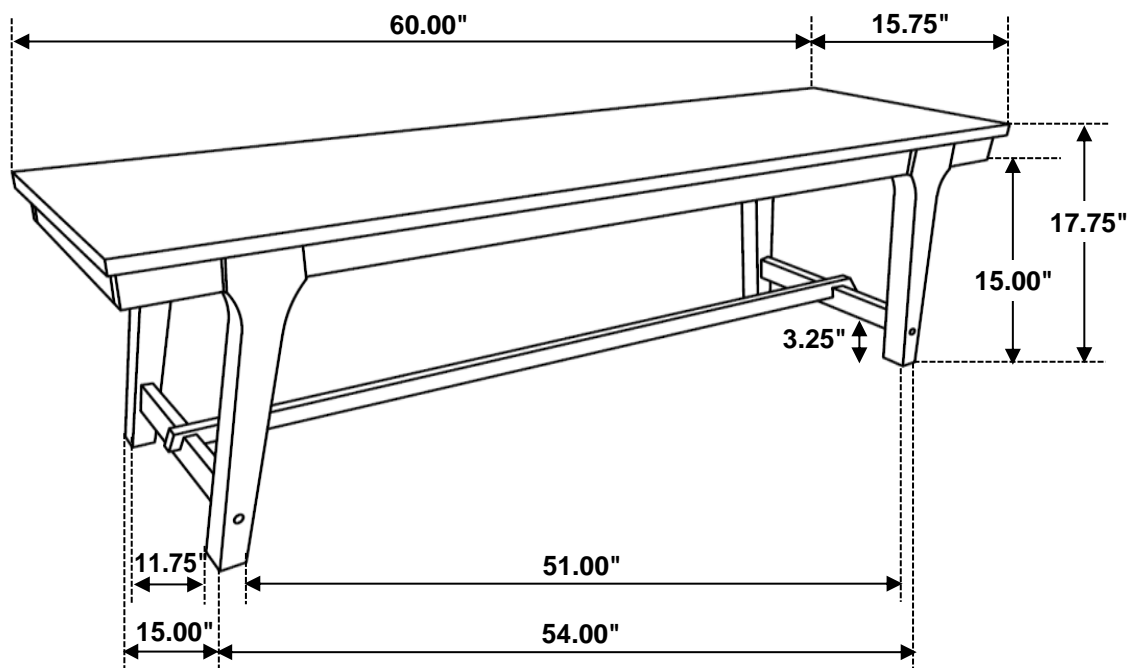

Note: Dimension tolerance  $\pm 5\%$