

ASSEMBLY INSTRUCTIONS
COASTER FINE FURNITURE



Fine Furniture for every stage of life

205101KW (B1-B3)
California King Bed

ITEM: 205101KW (B1-B3)



ASSEMBLY INSTRUCTIONS

ASSEMBLY TIPS:

1. Remove hardware from box and sort by size.
2. Please check to see that all hardware and parts are present prior to start of assembly.
3. Please follow attached instructions in the same sequence as numbered to assure fast & easy assembly.



WARNING!

1. Don't attempt to repair or modify parts that are broken or defective. Please contact the store immediately.
2. This product is for home use only and not intended for commercial establishments.





ASSEMBLY TIME



40 MINUTES

PARTS IDENTIFICATION





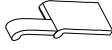





B1 (BOX 1)

A	HEADBOARD		1PC	C	HEADBOARD PANEL		1PC
B	HEADBOARD SUPPORT LEG		2PCS				

B2 (BOX 2)

D	RIGHT EAR PANEL		1PC	F	EAR PANEL SUPPORT		2PCS
E	LEFT EAR PANEL		1PC				

B3 (BOX 3)

G	FOOTBOARD		1PC	M	FOOTBOARD LEG		2PCS
H	LEFT BED RAIL		1PC	N	CENTER RAIL		2PCS
I	RIGHT BED RAIL		1PC	O	CENTER RAIL SUPPORT		2PCS
J	BED SLAT		10PCS	HB	205101KW (B1) FROM BOX 1 HEADBOARD COMPLETE		1PC
K	BED SLAT WITH HOLES		3PCS	ER	205101KW (B2) FROM BOX 2 LEFT AND RIGHT EAR PANEL COMPLETE		2PCS
L	BED SLAT SUPPORT		6PCS				

NOTE:

Phillips head screw driver is required in the assembly process; however, manufacturer does not provide this item.

ITEM: 205101KW (B1-B3)



ASSEMBLY INSTRUCTIONS

ASSEMBLY TIPS:

1. Remove hardware from box and sort by size.
2. Please check to see that all hardware and parts are present prior to start of assembly.
3. Please follow attached instructions in the same sequence as numbered to assure fast & easy assembly.















WARNING!

1. Don't attempt to repair or modify parts that are broken or defective. Please contact the store immediately.
2. This product is for home use only and not intended for commercial establishments.

HARDWARE IDENTIFICATION

Z-B3 (BOX 3) - HARDWARE PACK IS LOCATED IN 205101KW (B3)

1	ALLEN WRENCH (4MM - RBW)		1PC	7	MEDIUM PAN HEAD SCREW (#4 x 25mm - RBW)		4PCS
2	BOLT 1 (Ø1/4" x 30mm - RBW)		4PCS	8	LONG PAN HEAD SCREW (#4 x 38mm - RBW)		32PCS
3	BOLT 2 (Ø1/4" x 38mm - RBW)		10PCS	9	BIG FLAT WASHER (Ø1/4" X 25 X 1.5mm - RBW)		22PCS
4	BOLT 3 (Ø1/4" x 60mm - RBW)		10PCS	10	SMALL FLAT WASHER (Ø1/4" X 19 X 1.5mm - RBW)		22PCS
5	BOLT 4 (Ø1/4" x 90mm - RBW)		8PCS	11	LOCK WASHER (Ø1/4" - RBW)		22PCS
6	SHORT PAN HEAD SCREW (#4 x 20mm - RBW)		4PCS	12	LEVELER (Ø1/4" X 25mm - BLK)		6PCS

NOTE:

Phillips head screw driver is required in the assembly process; however, manufacturer does not provide this item.

ASSEMBLY INSTRUCTIONS

STEP 1

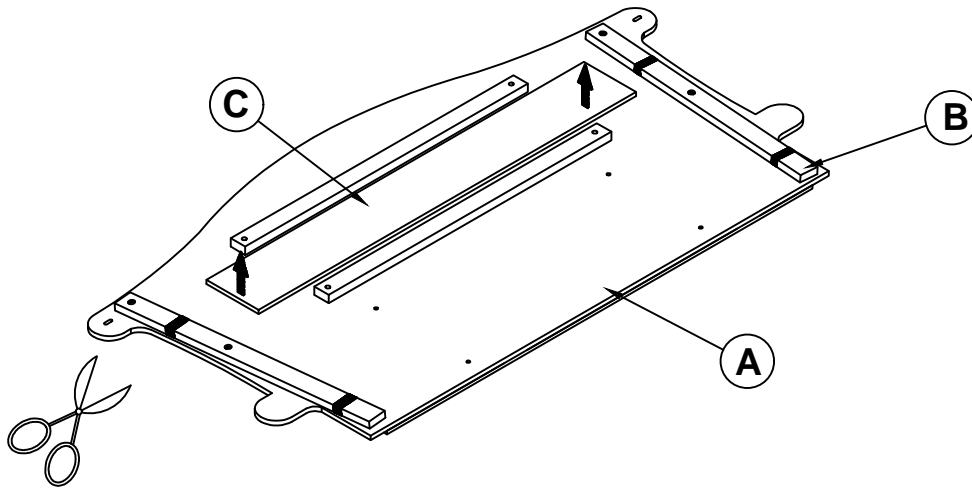

STEP 2

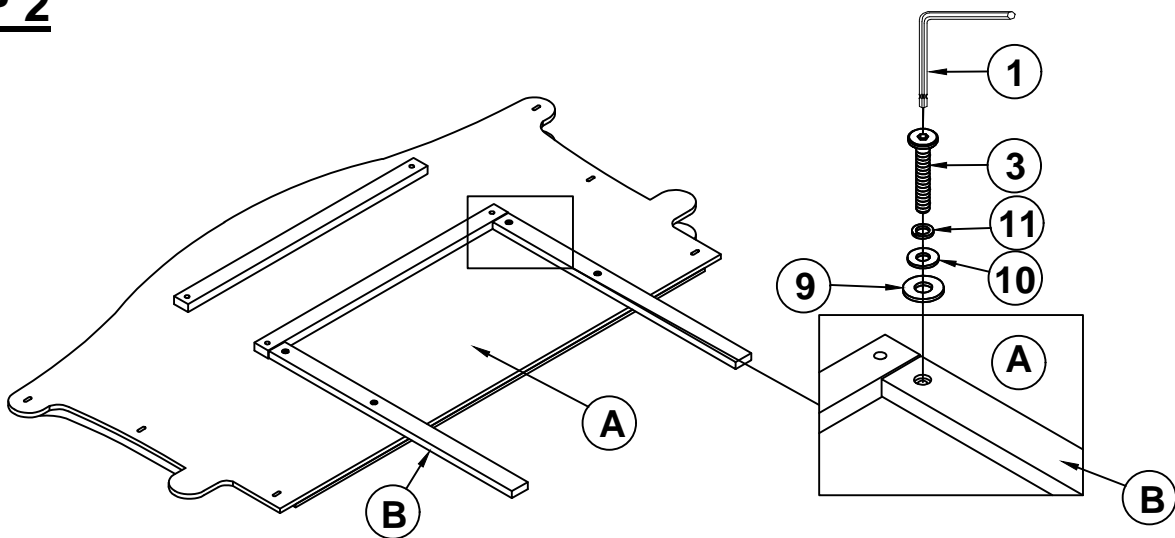

STEP 3

NOTE : THE EAR PANELSUPPORTS ARE TO LIFT UP THE BED RAILS

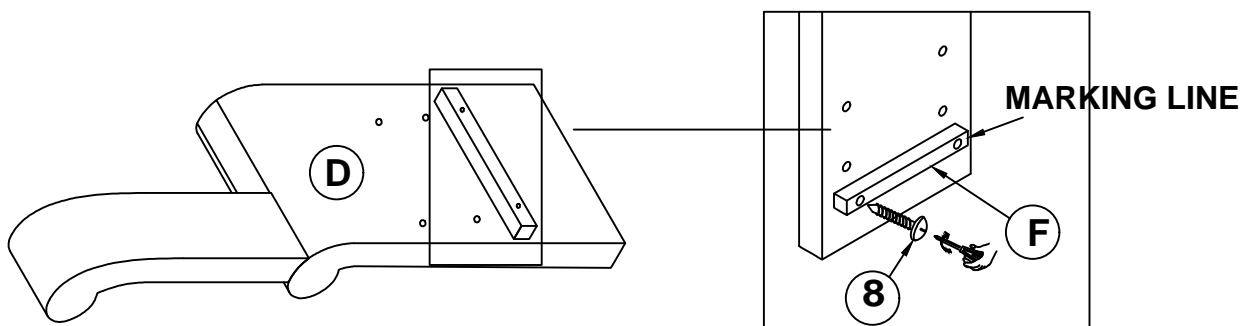

ASSEMBLY INSTRUCTIONS

STEP 4

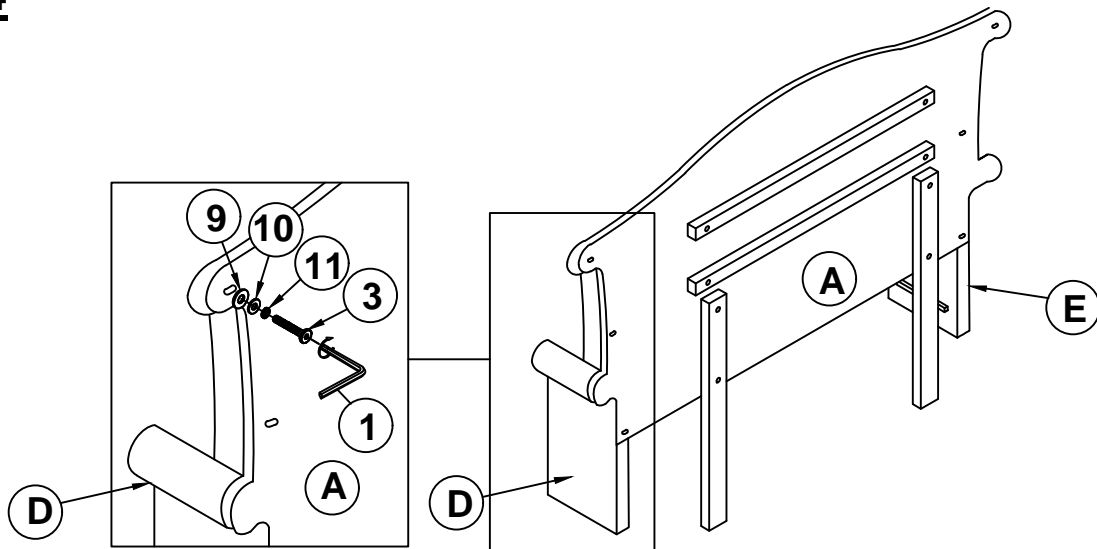

STEP 5

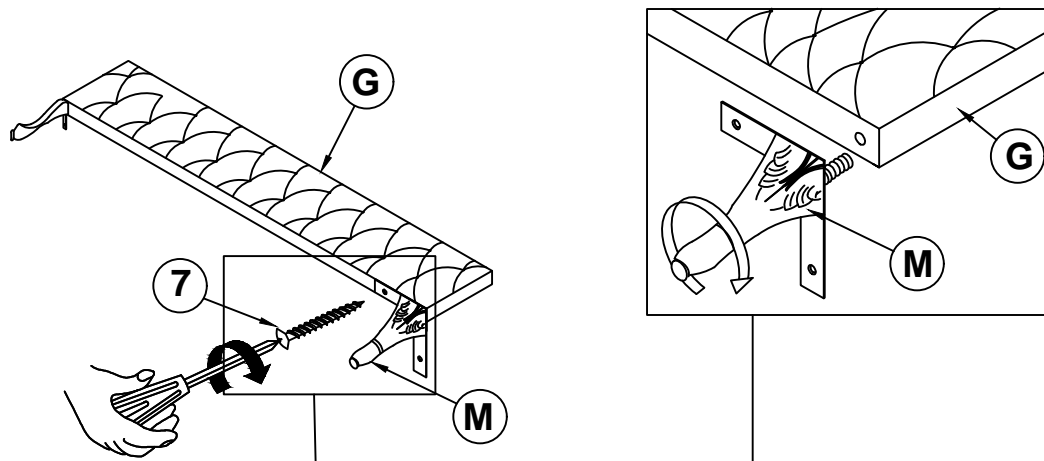

STEP 6

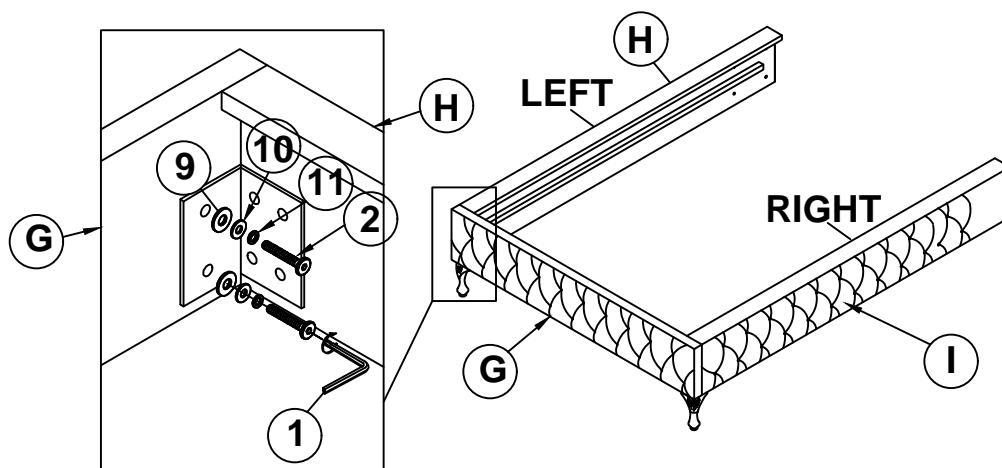

ASSEMBLY INSTRUCTIONS

STEP 7

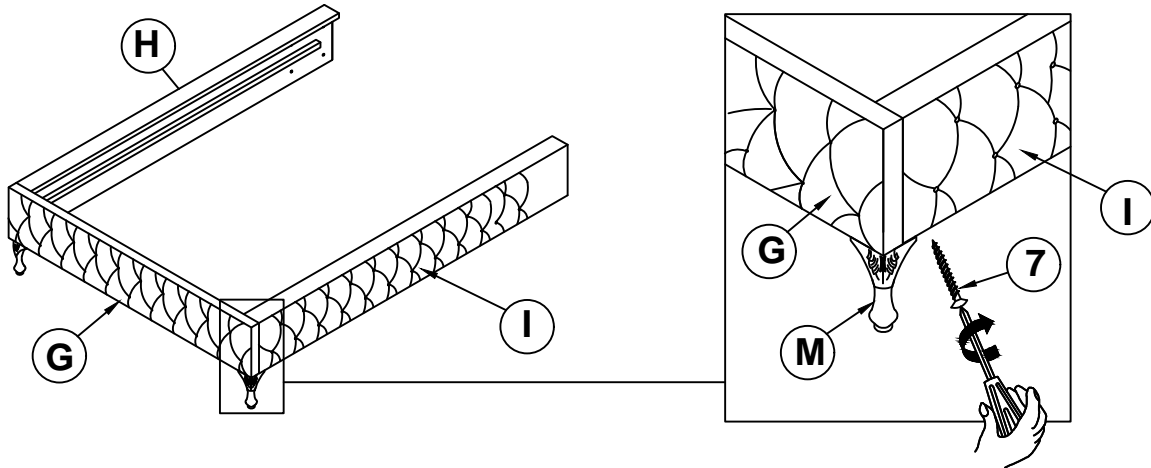

STEP 8

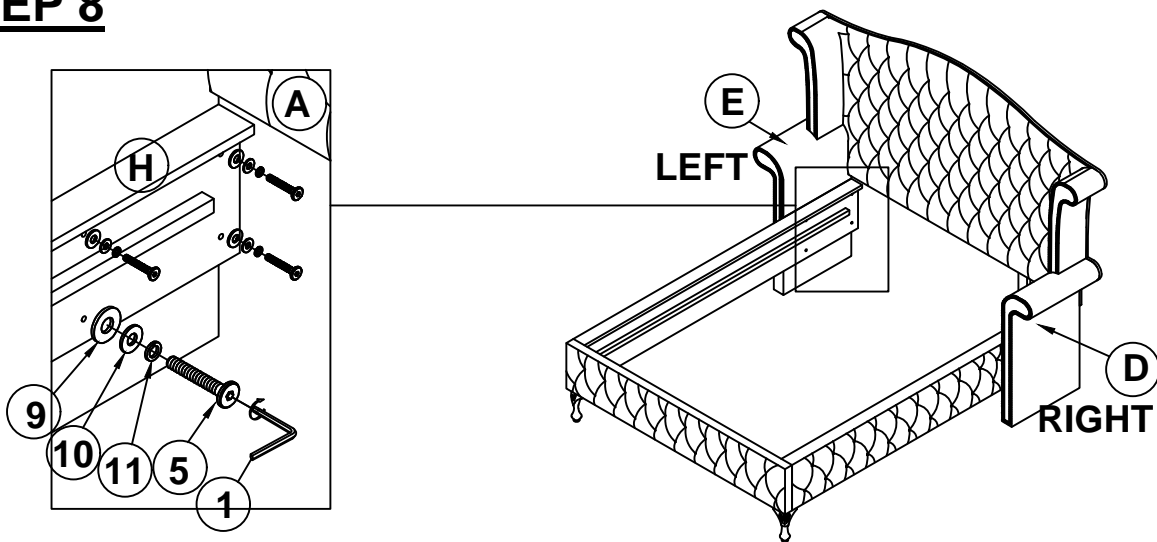

STEP 9

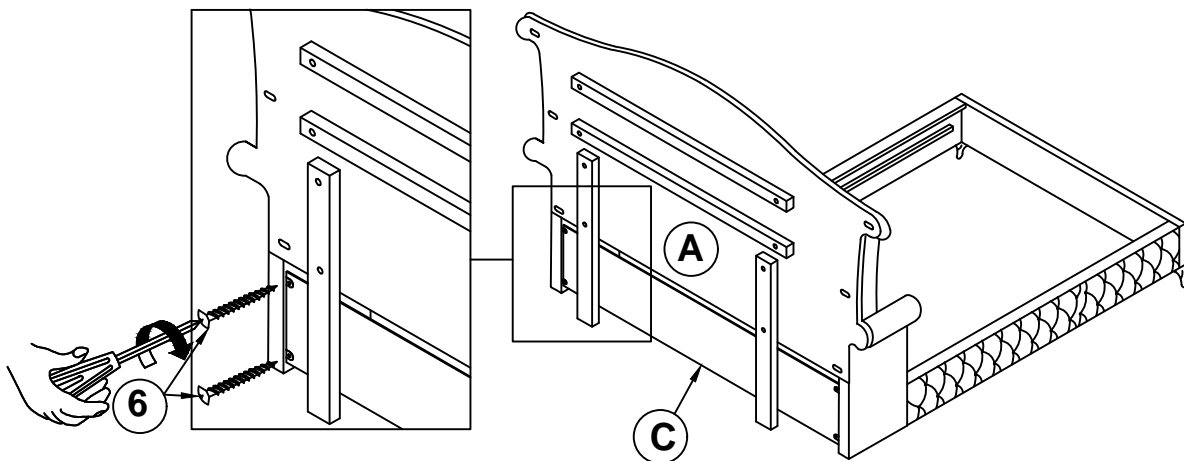

ASSEMBLY INSTRUCTIONS

STEP 10

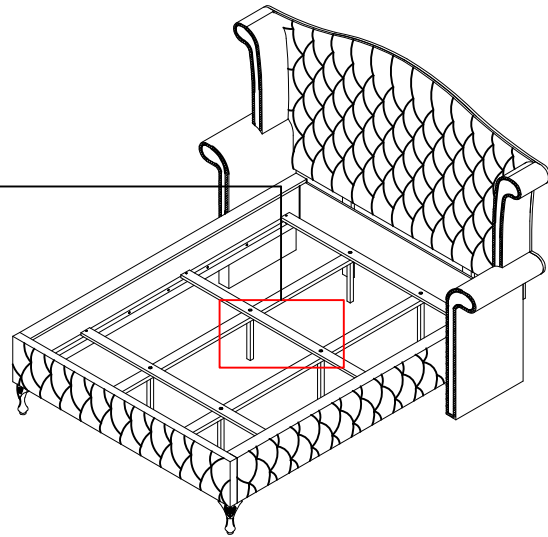
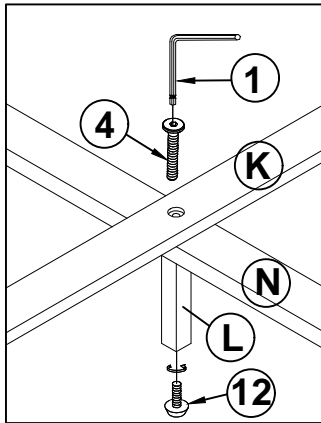

STEP 11

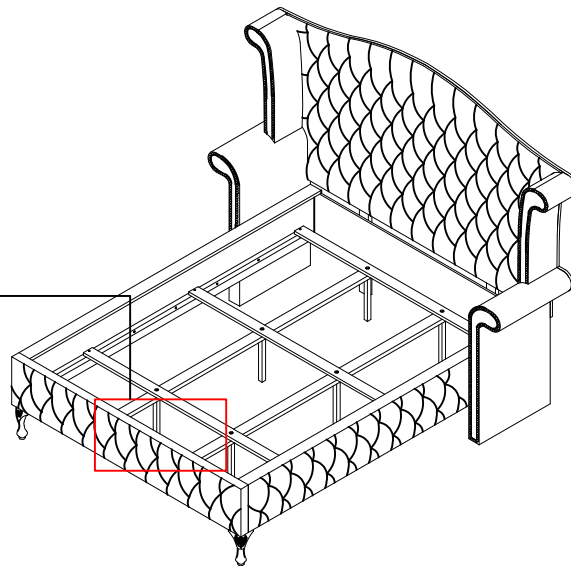
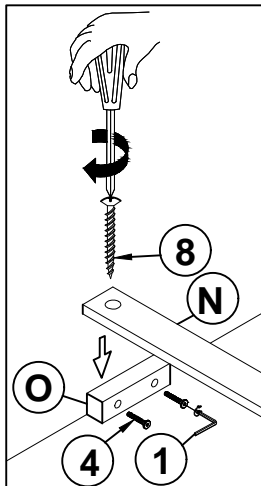

STEP 12

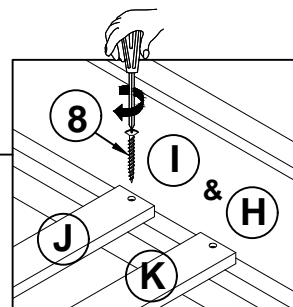
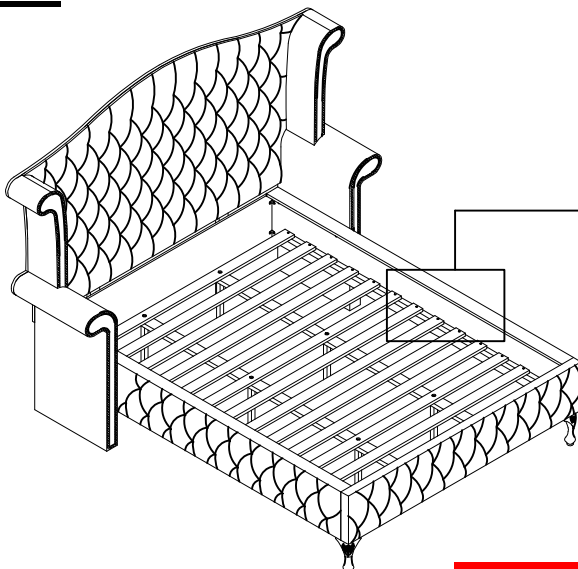

ITEM: **205101KW (B1-B3)**



ASSEMBLY INSTRUCTIONS

STEP 13

COMPLETE

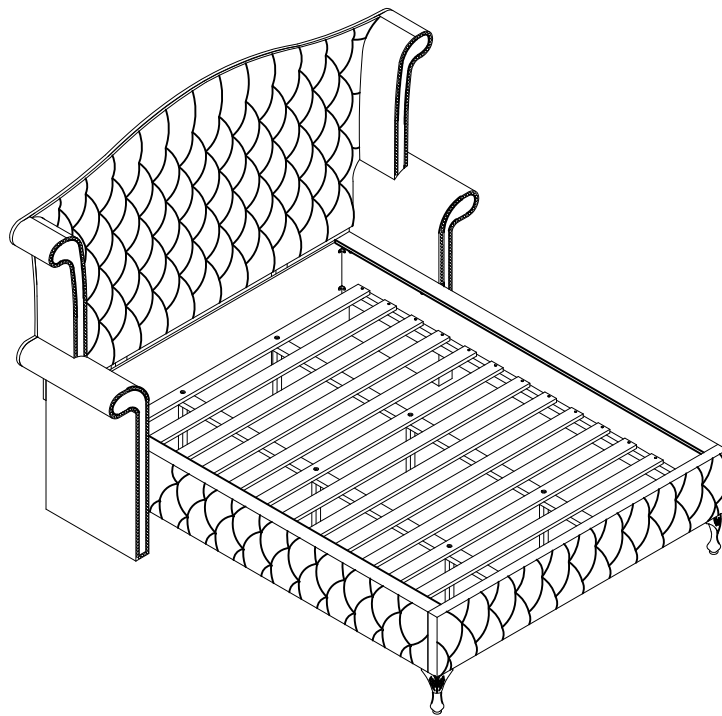

ITEM: 205101KW (B1-B3)



Inner Size: 73.50"W X 85.25"D

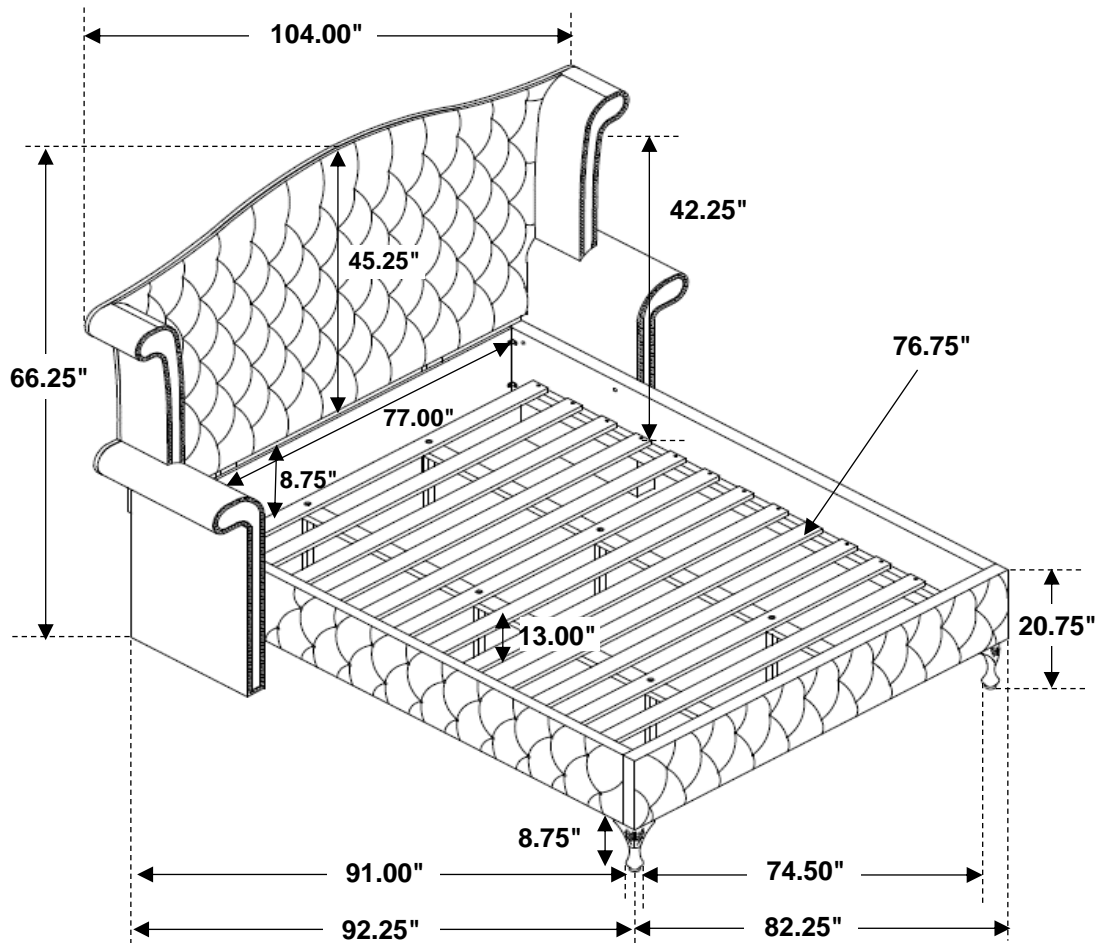

Note: Dimension tolerance $\pm 5\%$