

**ASSEMBLY INSTRUCTIONS**  
**COASTER FINE FURNITURE**



*Fine Furniture for every stage of life*

**206101KW (B1-B3)**  
***California King Bed***

# ITEM: 206101KW (B1-B3)



## ASSEMBLY INSTRUCTIONS

### ASSEMBLY TIPS:

1. Remove hardware from box and sort by size.
2. Please check to see that all hardware and parts are present prior to start of assembly.
3. Please follow attached instructions in the same sequence as numbered to assure fast & easy assembly.



### WARNING!

1. Don't attempt to repair or modify parts that are broken or defective. Please contact the store immediately.
2. This product is for home use only and not intended for commercial establishments.





**ASSEMBLY TIME**

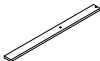

**40 MINUTES**

## PARTS IDENTIFICATION





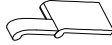





### B1 ( BOX 1 )

<p><b>A HEADBOARD</b>  <b>1PC</b></p> <p><b>B HEADBOARD SUPPORT LEG</b>  <b>2PCS</b></p>	<p><b>C HEADBOARD PANEL</b>  <b>1PC</b></p>
--	--

### B2 ( BOX 2 )

<p><b>D RIGHT EAR PANEL</b>  <b>1PC</b></p> <p><b>E LEFT EAR PANEL</b>  <b>1PC</b></p>	<p><b>F EAR PANEL SUPPORT</b>  <b>2PCS</b></p>
--	---

### B3 ( BOX 3 )

<p><b>G FOOTBOARD</b>  <b>1PC</b></p> <p><b>H LEFT BED RAIL</b>  <b>1PC</b></p> <p><b>I RIGHT BED RAIL</b>  <b>1PC</b></p> <p><b>J BED SLAT</b>  <b>10PCS</b></p> <p><b>K BED SLAT WITH HOLES</b>  <b>3PCS</b></p> <p><b>L BED SLAT SUPPORT</b>  <b>6PCS</b></p>	<p><b>M FOOTBOARD LEG</b>  <b>2PCS</b></p> <p><b>N CENTER RAIL</b>  <b>2PCS</b></p> <p><b>O CENTER RAIL SUPPORT</b>  <b>2PCS</b></p> <p><b>HB 206101KW (B1) FROM BOX 1 HEADBOARD COMPLETE</b>  <b>1PC</b></p> <p><b>ER 206101KW (B2) FROM BOX 2 LEFT AND RIGHT EAR PANEL COMPLETE</b>  <b>2PCS</b></p>
--	---

### NOTE:

Phillips head screw driver is required in the assembly process; however, manufacturer does not provide this item.

# ITEM: 206101KW (B1-B3)



## ASSEMBLY INSTRUCTIONS

### ASSEMBLY TIPS:

1. Remove hardware from box and sort by size.
2. Please check to see that all hardware and parts are present prior to start of assembly.
3. Please follow attached instructions in the same sequence as numbered to assure fast & easy assembly.















### WARNING!

1. Don't attempt to repair or modify parts that are broken or defective. Please contact the store immediately.
2. This product is for home use only and not intended for commercial establishments.

## HARDWARE IDENTIFICATION

### Z-B3 (BOX 3) - HARDWARE PACK IS LOCATED IN 206101KW (B3)

1	<b>ALLEN WRENCH</b> (4MM - RBW)		1PC	7	<b>MEDIUM PAN HEAD SCREW</b> (#4 x 25mm - RBW)		4PCS
2	<b>BOLT 1</b> (Ø1/4" x 30mm - RBW)		4PCS	8	<b>LONG PAN HEAD SCREW</b> (#4 x 38mm - RBW)		32PCS
3	<b>BOLT 2</b> (Ø1/4" x 38mm - RBW)		10PCS	9	<b>BIG FLAT WASHER</b> (Ø1/4" X 25 X 1.5mm - RBW)		22PCS
4	<b>BOLT 3</b> (Ø1/4" x 60mm - RBW)		10PCS	10	<b>SMALL FLAT WASHER</b> (Ø1/4" X 19 X 1.5mm - RBW)		22PCS
5	<b>BOLT 4</b> (Ø1/4" x 90mm - RBW)		8PCS	11	<b>LOCK WASHER</b> (Ø1/4" - RBW)		22PCS
6	<b>SHORT PAN HEAD SCREW</b> (#4 x 20mm - RBW)		4PCS	12	<b>LEVELER</b> (Ø1/4" X 25mm - BLK)		6PCS

### NOTE:

Phillips head screw driver is required in the assembly process; however, manufacturer does not provide this item.

**ASSEMBLY INSTRUCTIONS**

**STEP 1**

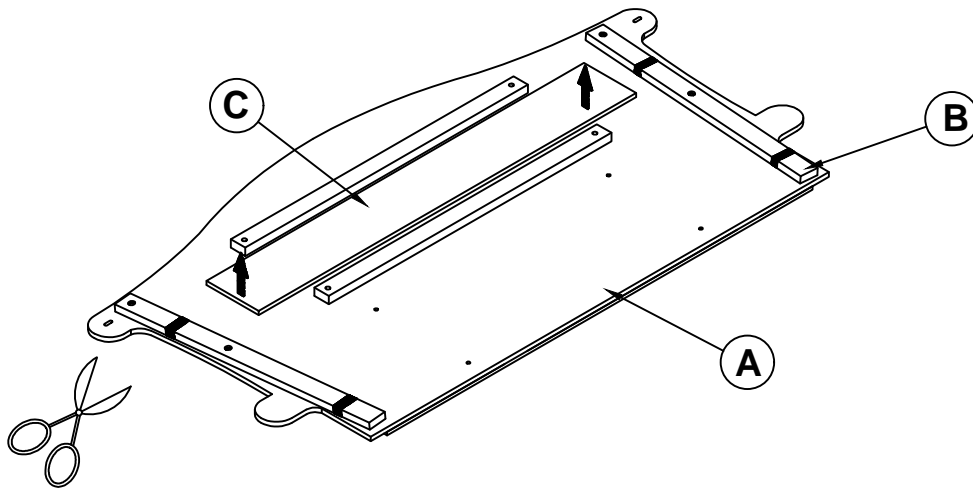

**STEP 2**

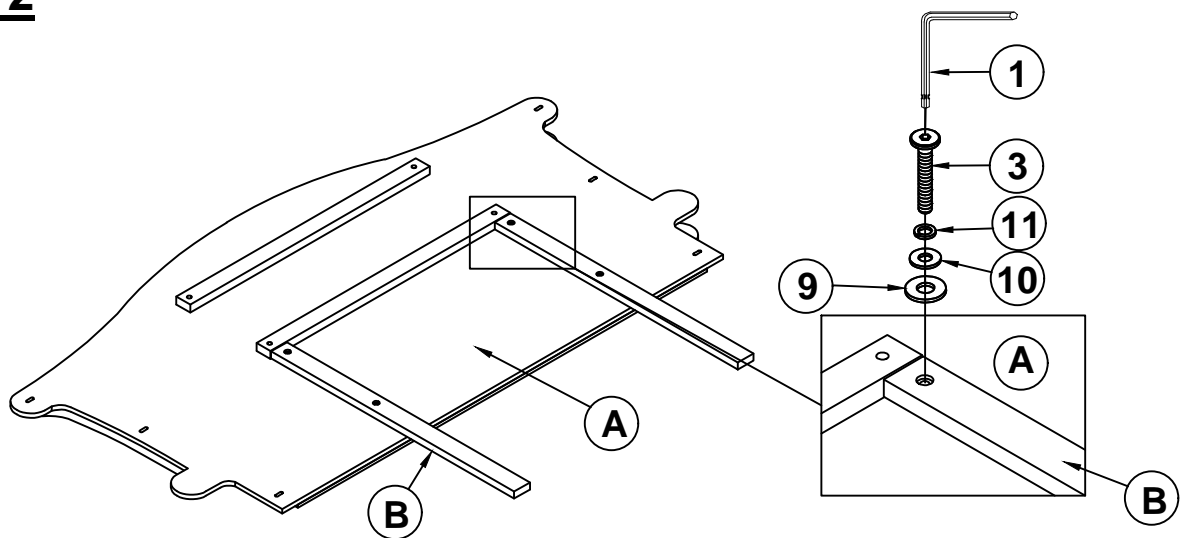

**STEP 3**

**NOTE : THE EAR PANELSUPPORTS ARE TO LIFT UP THE BED RAILS**

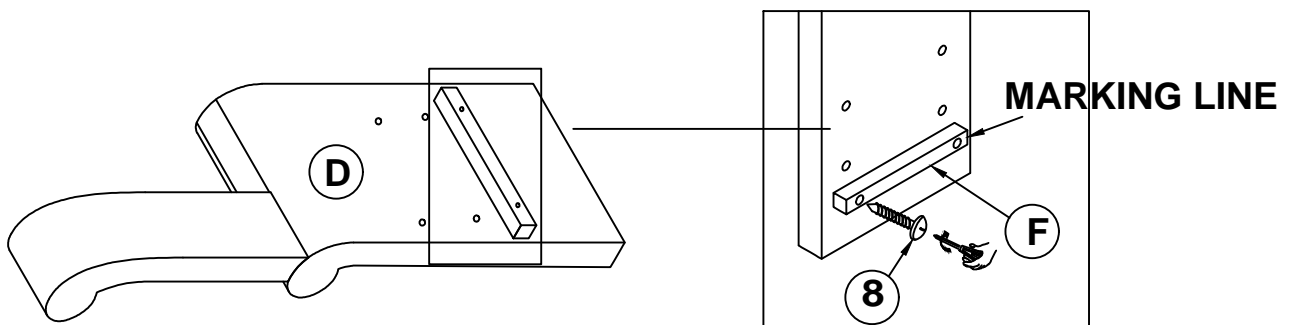

**ASSEMBLY INSTRUCTIONS**

**STEP 4**

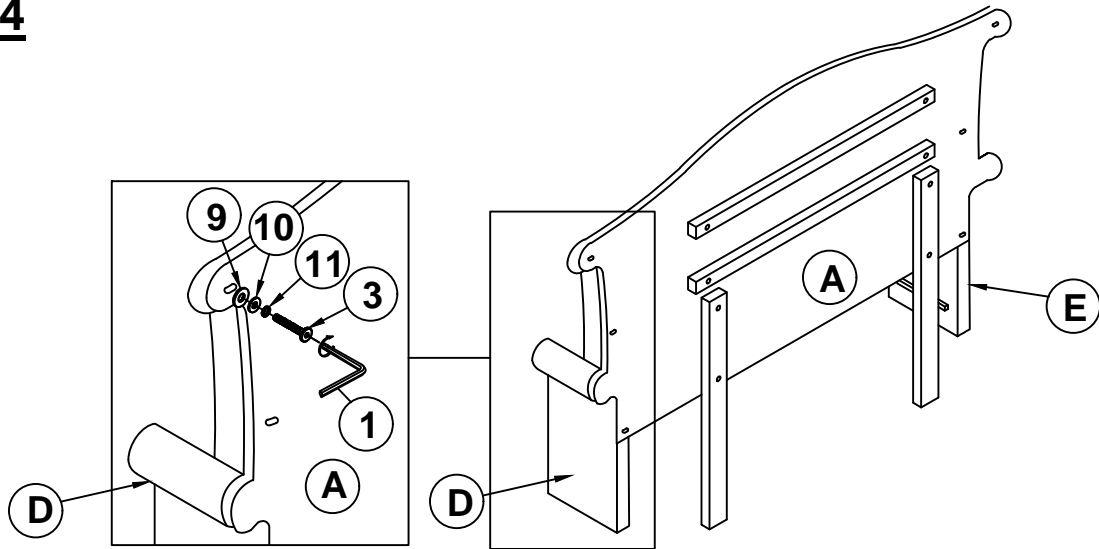

**STEP 5**

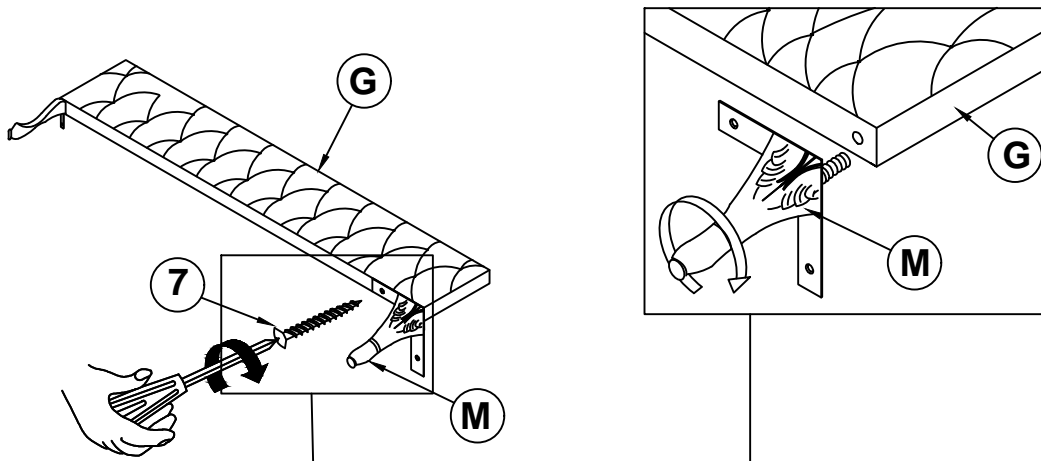

**STEP 6**

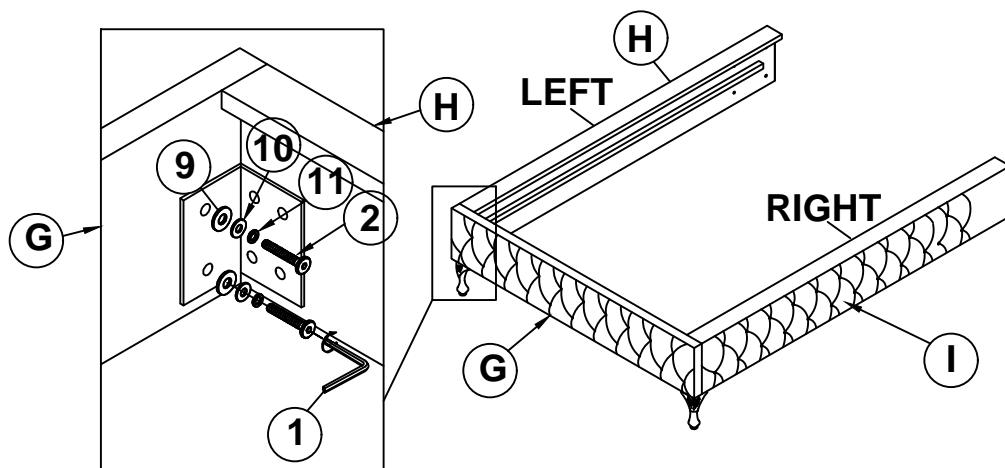

**ASSEMBLY INSTRUCTIONS**

**STEP 7**

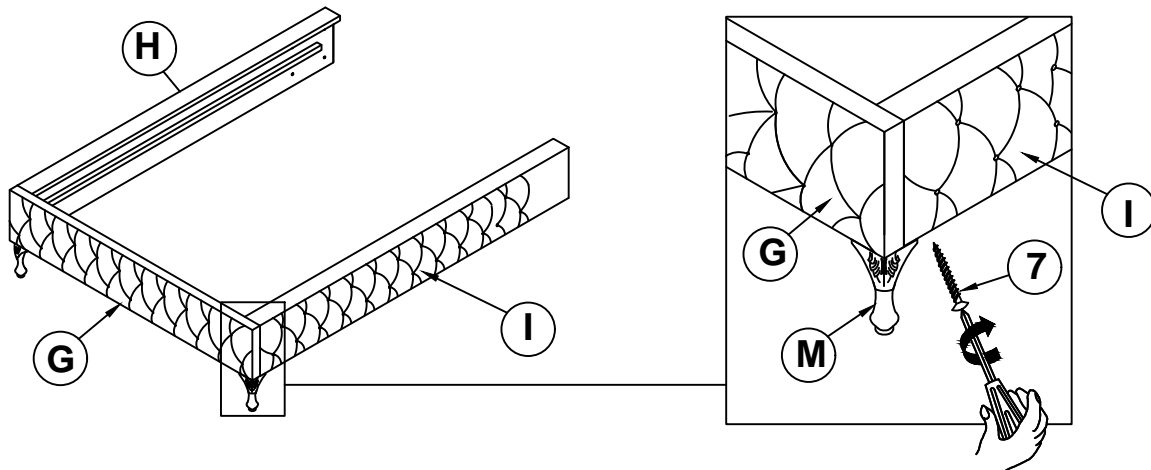

**STEP 8**

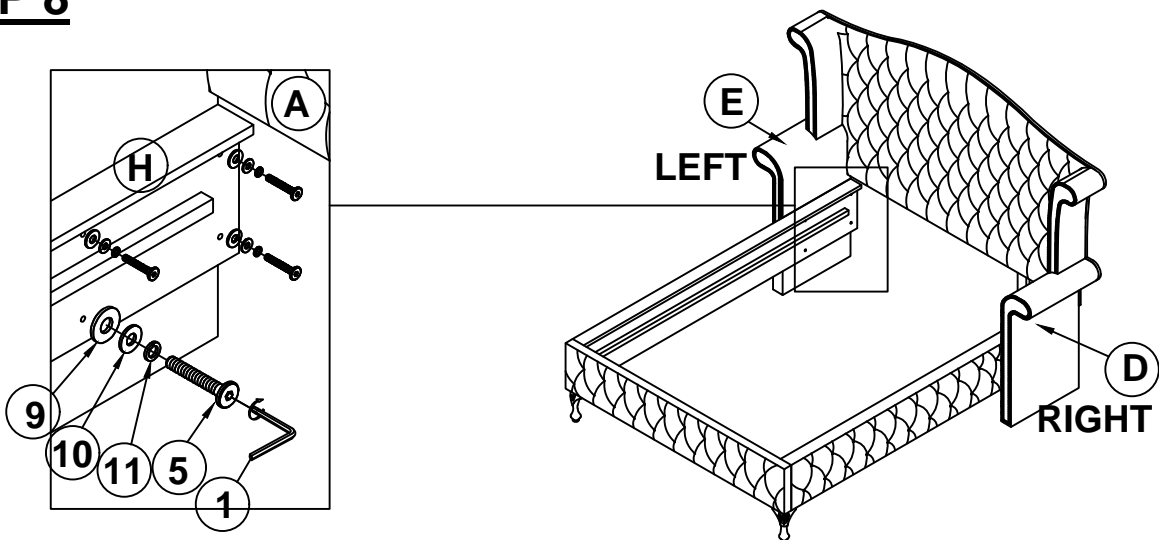

**STEP 9**

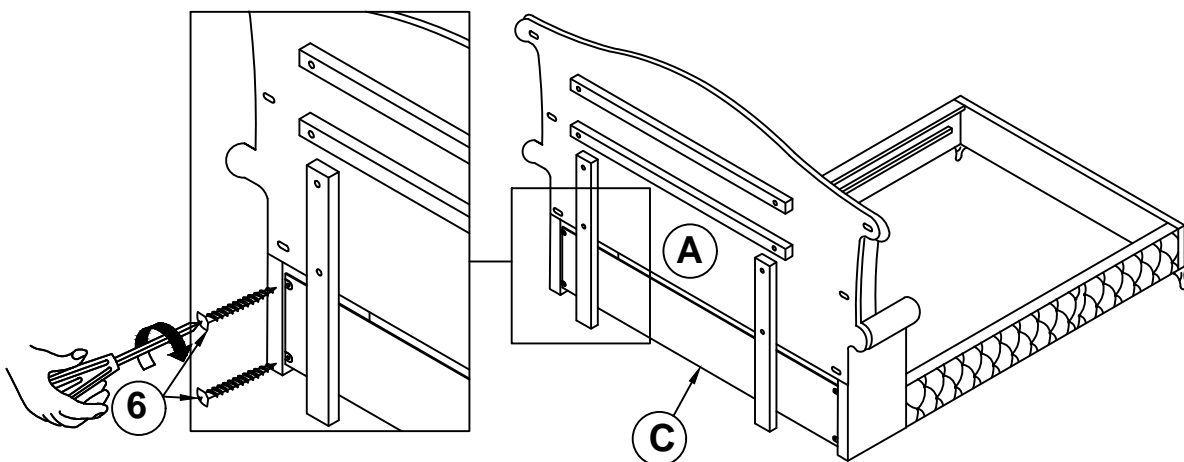

**ASSEMBLY INSTRUCTIONS**

**STEP 10**

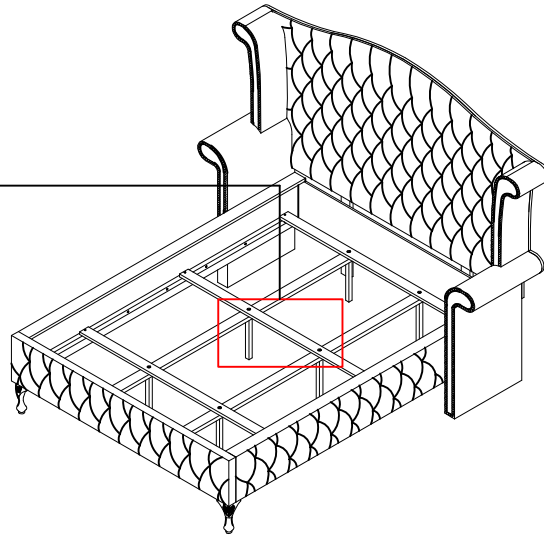
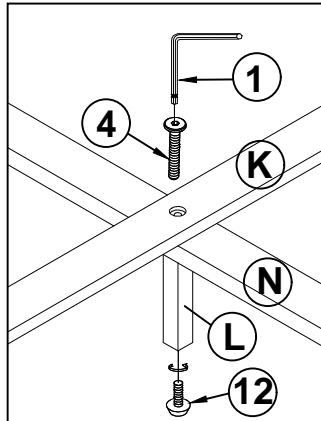

**STEP 11**

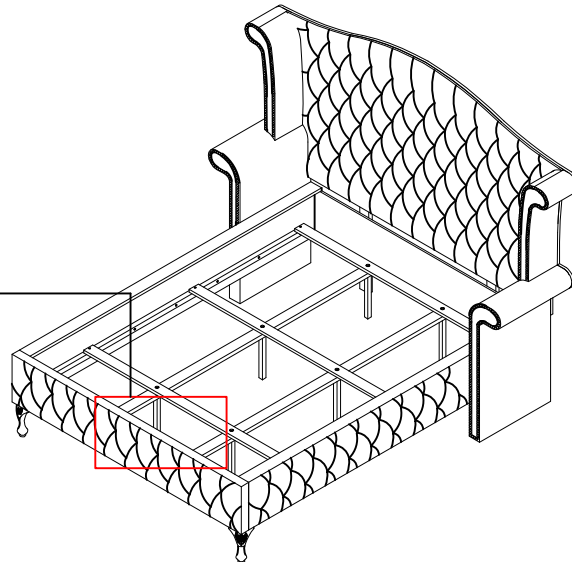
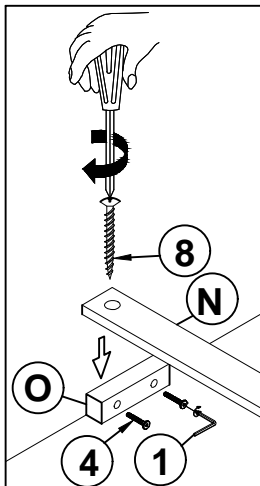

**STEP 12**

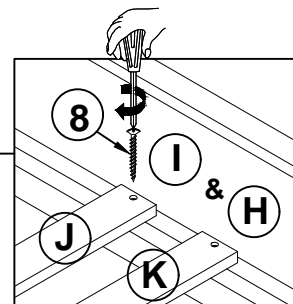
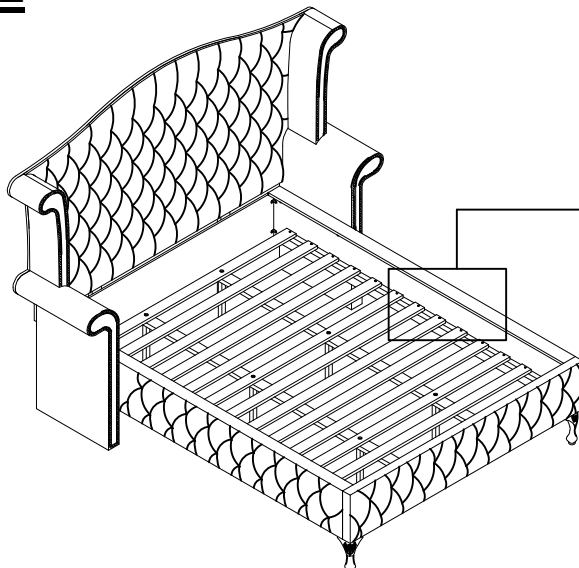

ITEM: **206101KW (B1-B3)**



**ASSEMBLY INSTRUCTIONS**

**STEP 13**

**COMPLETE**

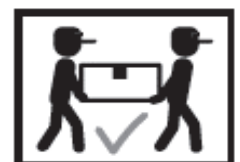
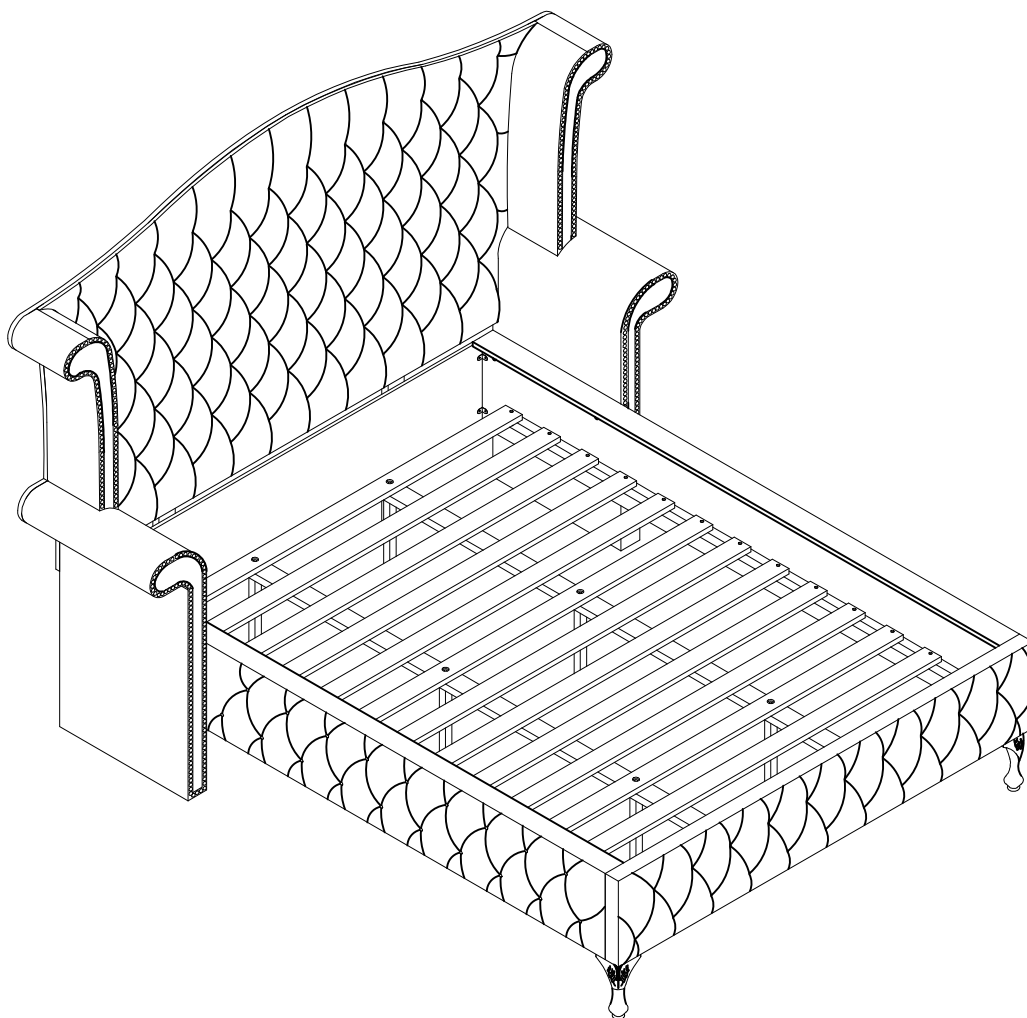



# ITEM: 206101KW (B1-B3)



Inner Size: 73.50"W X 85.25"D

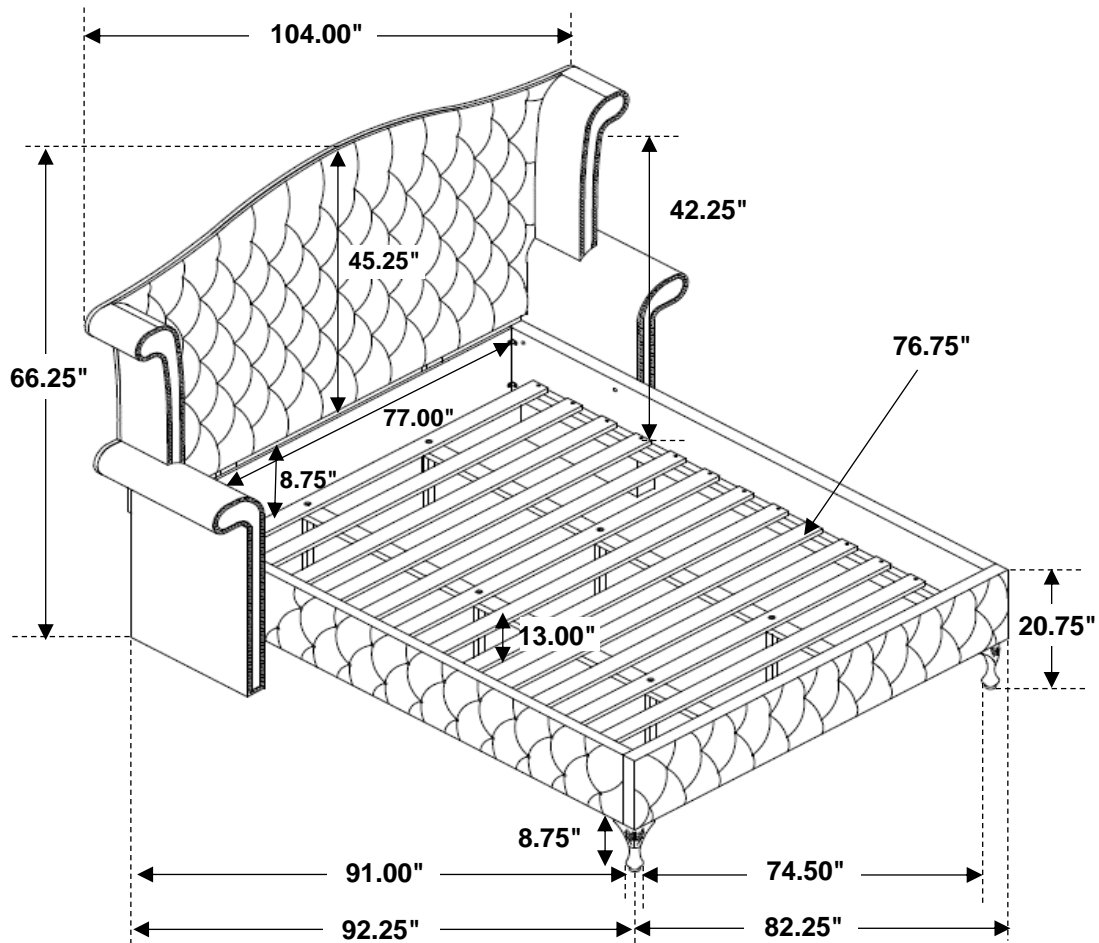

Note: Dimension tolerance  $\pm 5\%$