

**ASSEMBLY INSTRUCTIONS**  
**COASTER FINE FURNITURE**

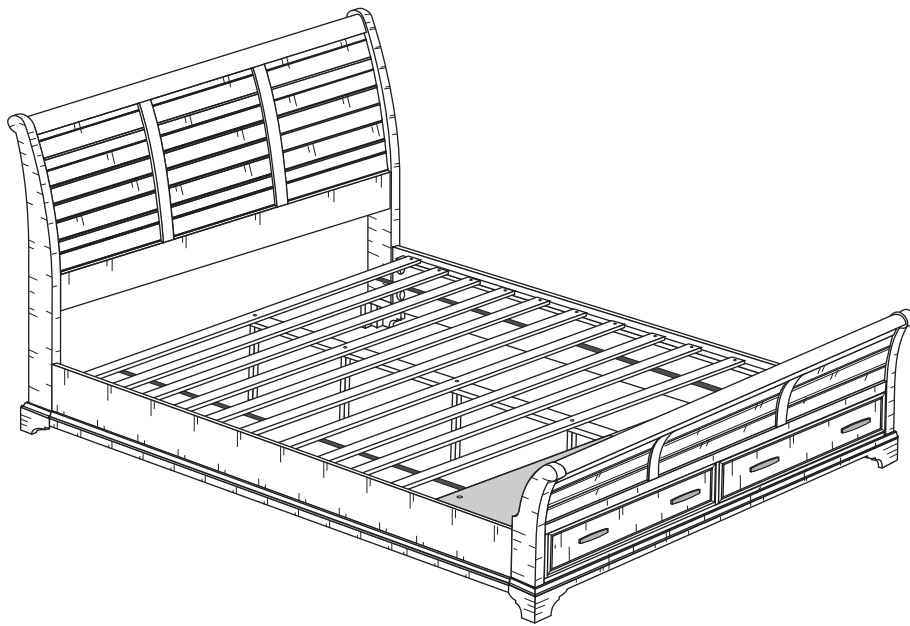

*Fine Furniture for every stage of life*

**203891Q (B1-B3)**  
**Queen Storage Bed**

REVISION 0: 12/30/2014  
REVISION 1: 03/19/2015  
REVISION 2: 10/16/2017  
REVISION 3: 08/23/2018  
REVISION 4: 01/03/2020  
REVISION 5: 05/25/2022

COASTERFURNITURE.COM

# ITEM: 203891Q (B1-B3)

## ASSEMBLY INSTRUCTIONS



### ASSEMBLY TIPS:

- 1 . Remove hardware from box and sort by size.
- 2 . Please check to see that all hardware and parts are present prior to start of assembly.
- 3 . Please follow attached instructions in the same sequence as numbered to assure fast & easy assembly.



### WARNING!

- 1 . Don't attempt to repair or modify parts that are broken or defective. Please contact the store immediately.
- 2 . This product is for home use only and not intended for commercial establishments.

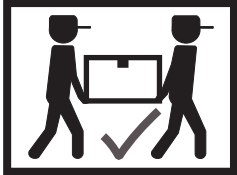

ASSEMBLY TIME

20 MINUTES

## PARTS IDENTIFICATION

### B1 (BOX 1)

A HEADBOARD

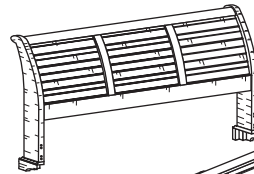

1PC

### B2 (BOX 2)

B STORAGE FOOTBOARD

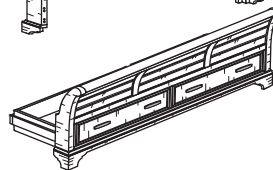

1PC

H FOOTBOARD SUPPORT LEG WITH LEVELER



2PCS

### B3 (BOX 3)

C BED RAIL



2PCS

D ROLL SLAT (6PCS)



2SETS

E CENTER RAIL



1PC

F CENTER RAIL SUPPORT WITH LEVELER



4PCS

G SHORT CENTER RAIL SUPPORT



1PC

I CONCEAL PANEL



2PCS

A 203891Q (B1) FROM BOX 1 HEADBOARD

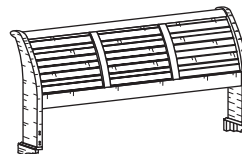

1PC

FB 203891Q (B2) FROM BOX 2 STORAGE FOOTBOARD COMPLETE

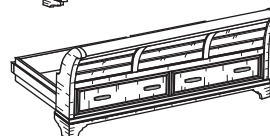

1PC

# ITEM: 203891Q (B1-B3)



## ASSEMBLY INSTRUCTIONS

### ASSEMBLY TIPS:

- 1 . Remove hardware from box and sort by size.
- 2 . Please check to see that all hardware and parts are present prior to start of assembly.
- 3 . Please follow attached instructions in the same sequence as numbered to assure fast & easy assembly.















### WARNING!

- 1 . Don't attempt to repair or modify parts that are broken or defective. Please contact the store immediately.
- 2 . This product is for home use only and not intended for commercial establishments.

## HARDWARE IDENTIFICATION

### Z-B3 (BOX 3) - HARDWARE PACK IS LOCATED IN 203891Q (B3)

1	<b>THREADED BOLT</b> (M6 x 70mm - RBW)		8PCS
2	<b>WOOD DOWEL</b> (Ø 10 x 30mm)		8PCS
3	<b>HALF ROUND NUT</b> (7 x 15mm- BLK)		8PCS
4	<b>SMALL FLAT WASHER</b> (M6 x 13mm - RBW)		8PCS
5	<b>HEX NUT</b> (M6 x 10mm - RBW)		8PCS
6	<b>WRENCH</b> (10 x 85mm - RBW)		1PC
7	<b>LONG FLAT HEAD SCREW</b> (M4 x 30mm - BLK)		24PCS
8	<b>SHORT FLAT HEAD SCREW</b> (M4 x 16mm - RBW)		8PCS
9	<b>LONG BOLT</b> (M6 x 60mm - RBW)		4PCS
10	<b>SHORT BOLT</b> (M6 x 40mm - RBW)		2PCS
11	<b>ALLEN WRENCH</b> (M4 x 58mm- BLK)		1PC
12	<b>BIG FLAT WASHER</b> (M6 x 19mm - RBW)		2PCS
13	<b>LOCK WASHER</b> (M6 x 13mm - RBW)		2PCS

### NOTE :

Phillips head screw driver is required in the assembly process; however, manufacturer does not provide this item.

# ITEM: 203891Q (B1-B3)

## ASSEMBLY INSTRUCTIONS



### STEP 1

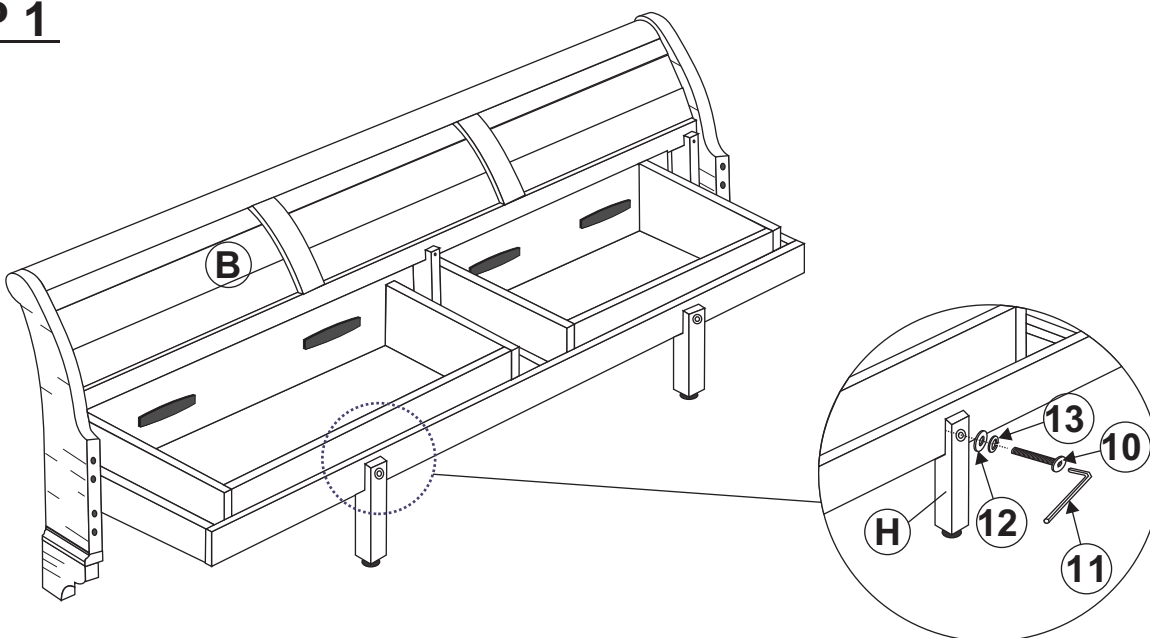

### STEP 2

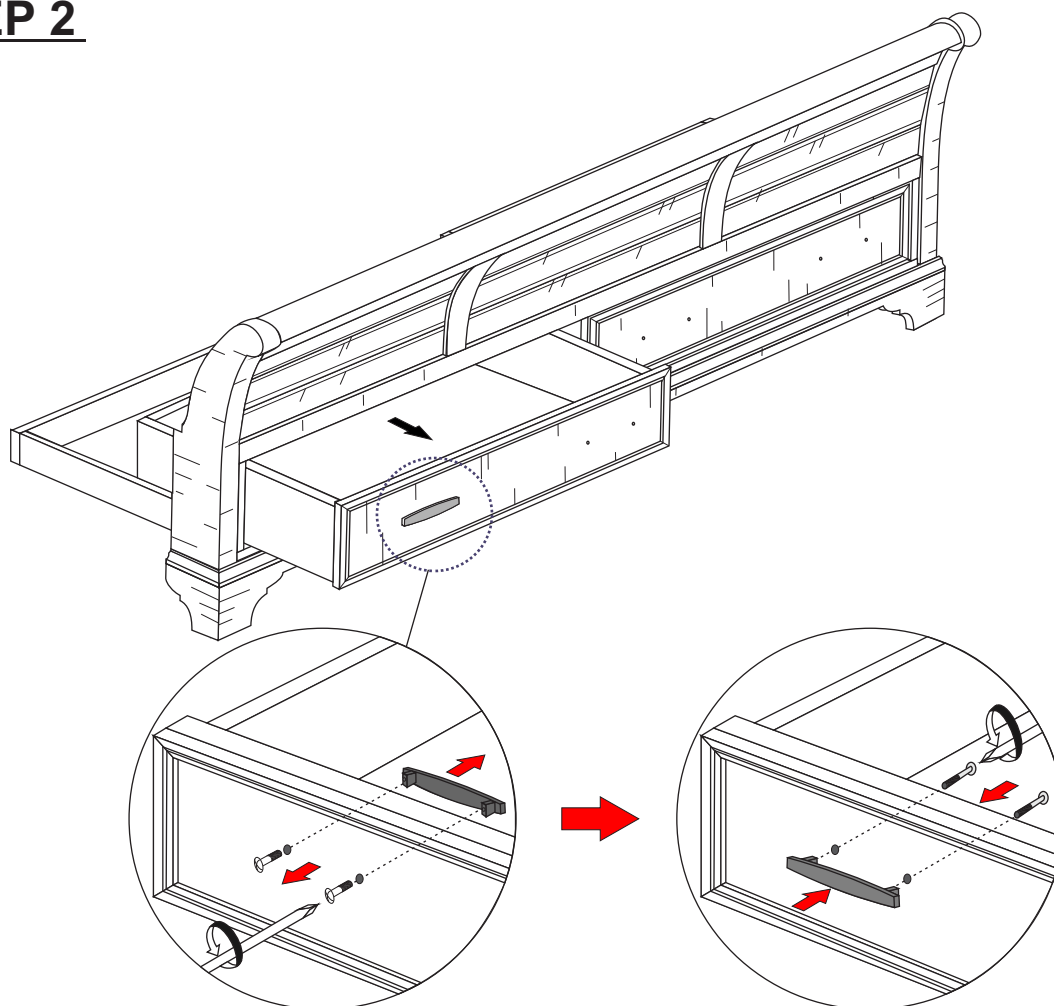

# ITEM: 203891Q (B1-B3)

## ASSEMBLY INSTRUCTIONS



### STEP 3

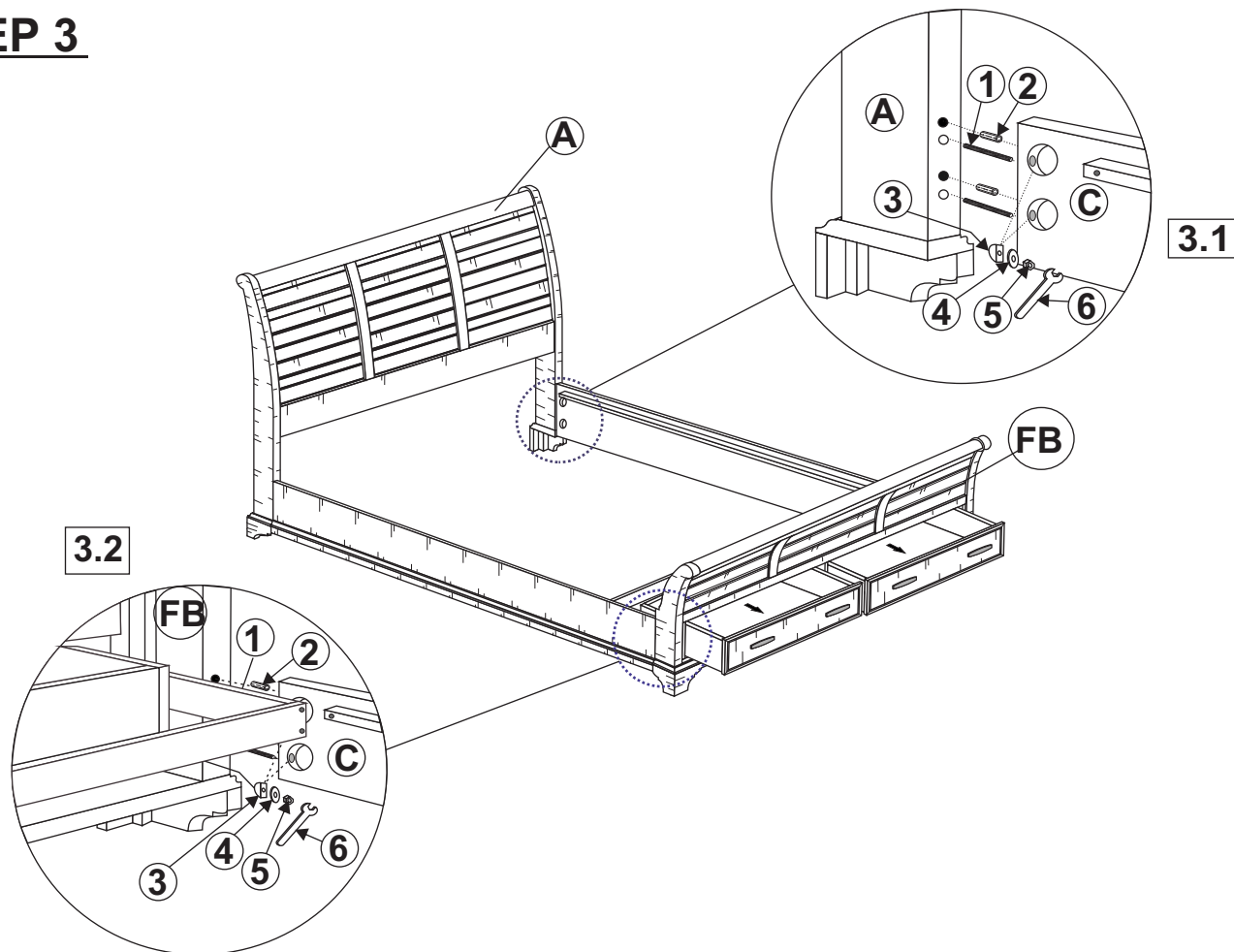

### STEP 4

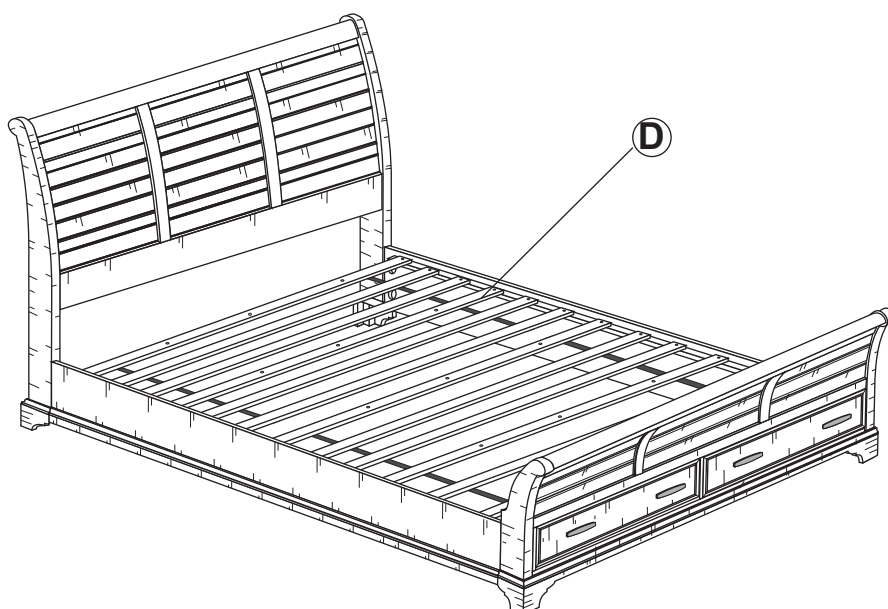

# ITEM: 203891Q (B1-B3)

## ASSEMBLY INSTRUCTIONS



### STEP 5

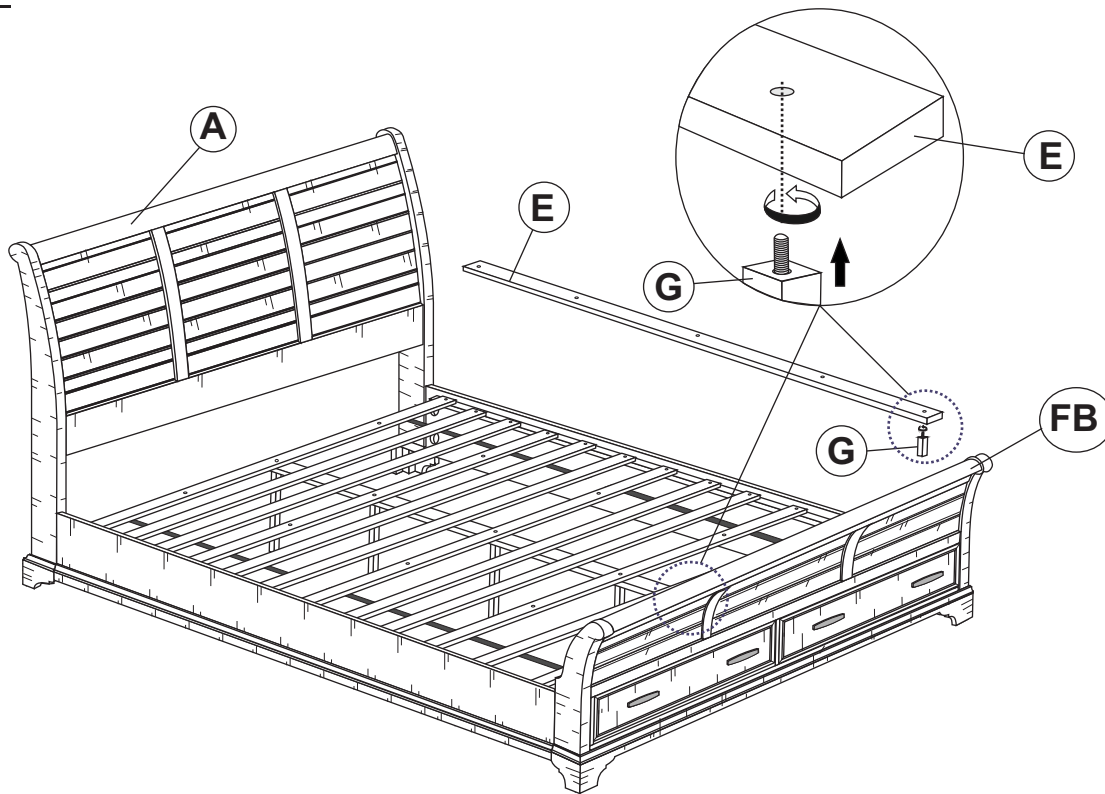

### STEP 6

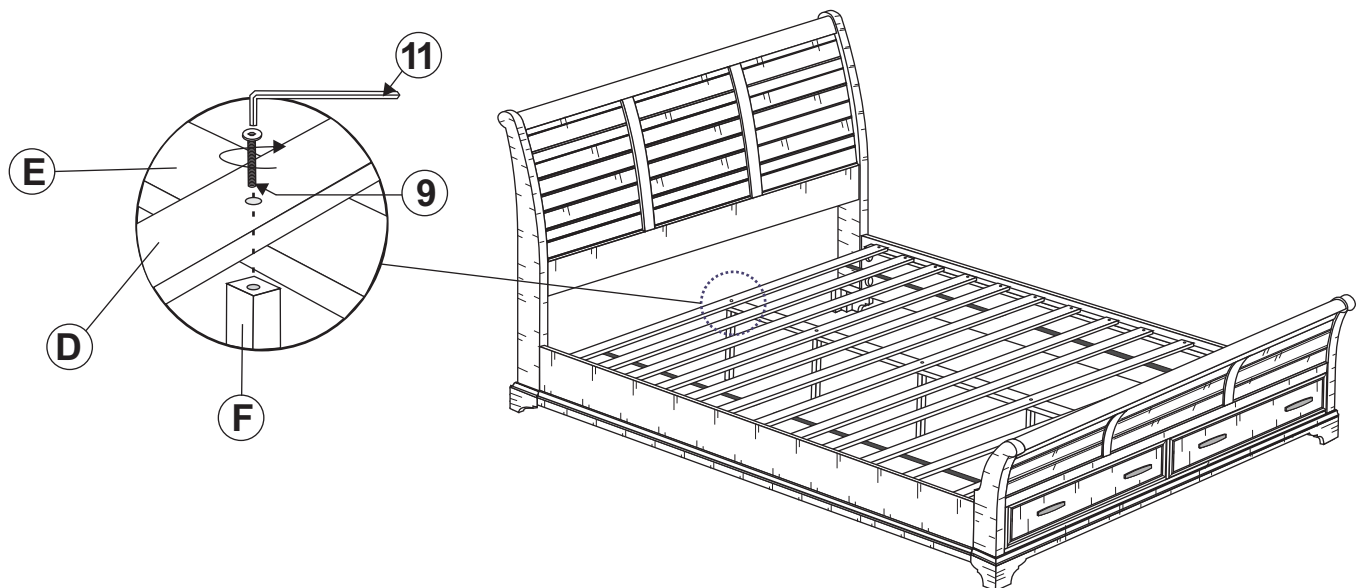



ITEM: **203891Q (B1-B3)**

**ASSEMBLY INSTRUCTIONS**



**STEP 7**

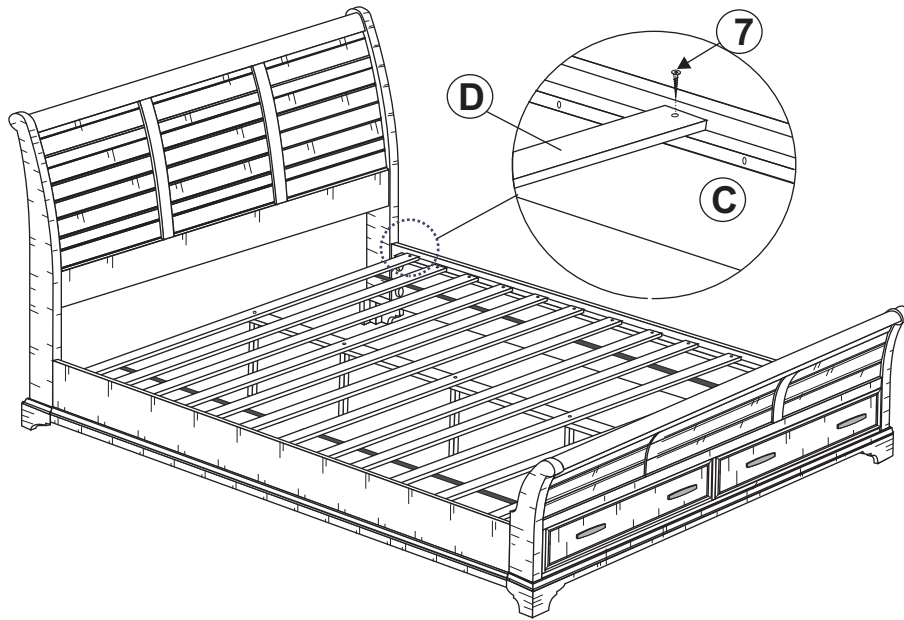

**STEP 8**

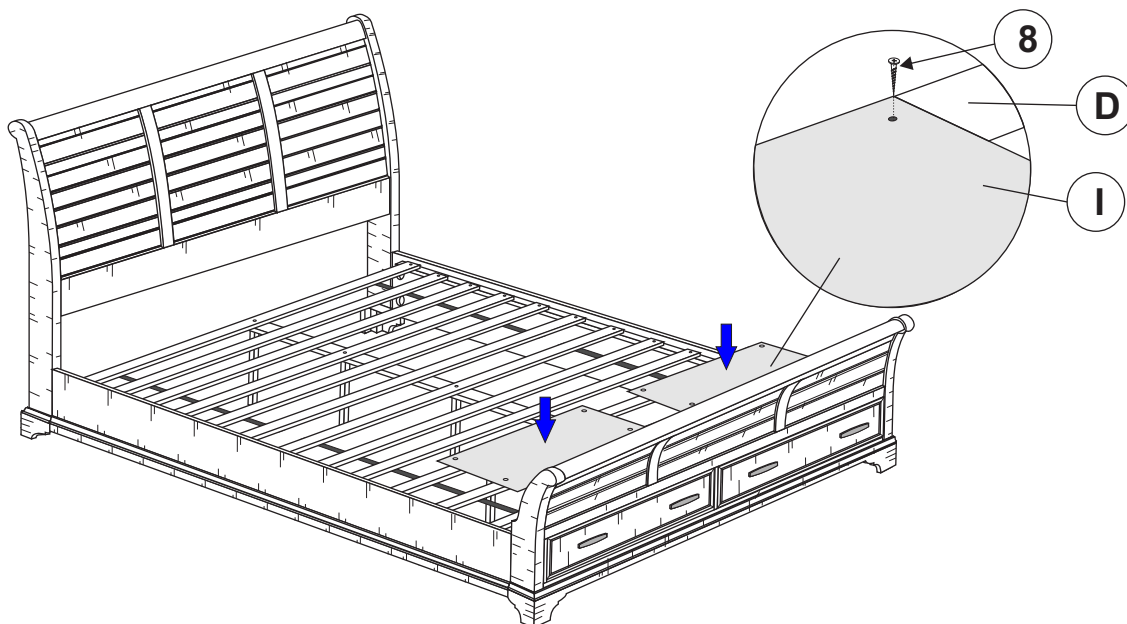

ITEM: **203891Q (B1-B3)**

**ASSEMBLY INSTRUCTIONS**



**STEP 9**

**COMPLETE**

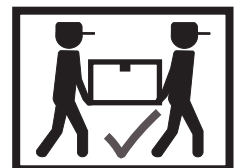
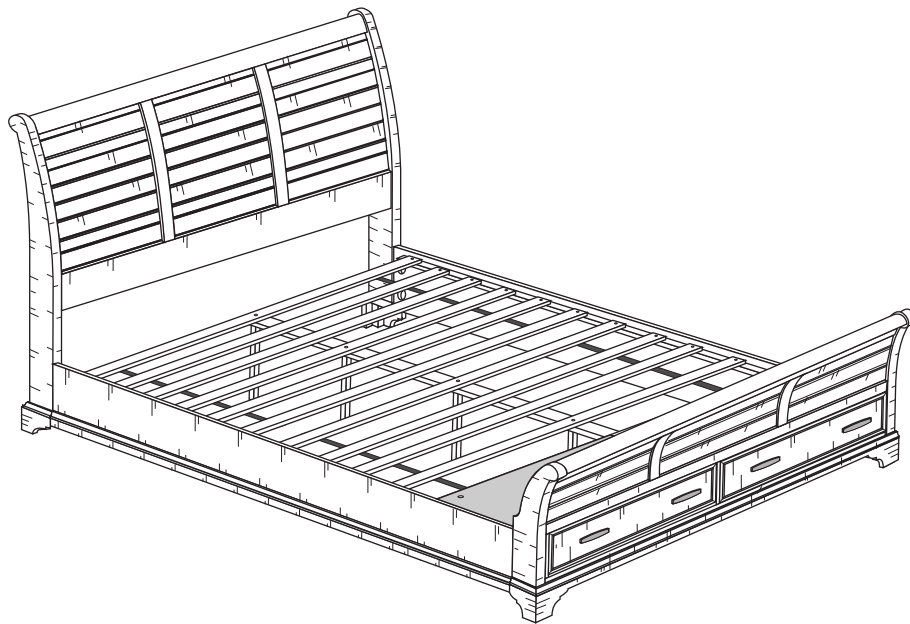



# ITEM: 203891Q (B1-B3)



Inner Size : 60.50"W X 81.00"D

Inner Size of Drawer : 25.00"W X 14.50"D X 6.50"H X 0.50"T

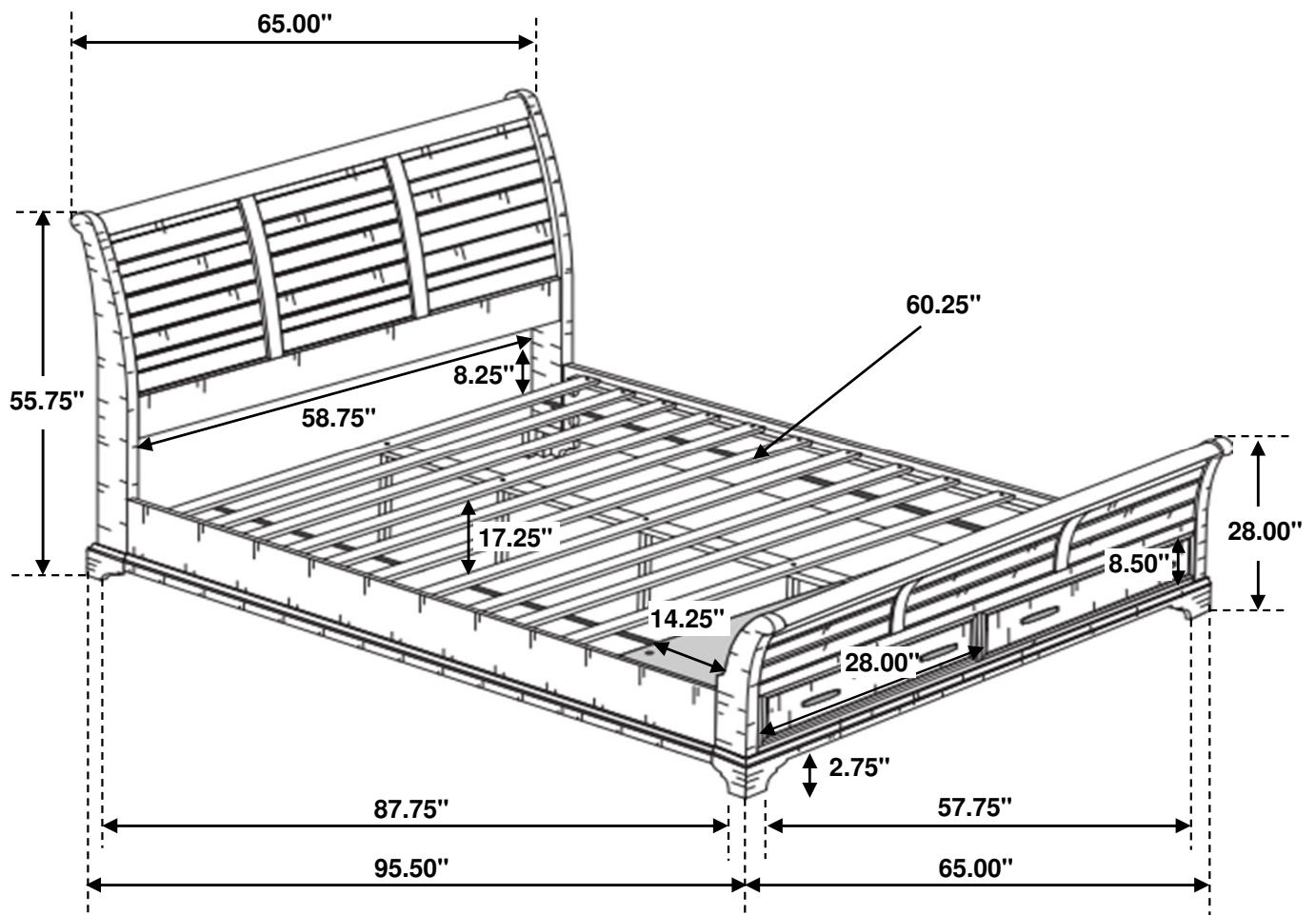

Note : Dimension tolerance  $\pm 5\%$