



ASSEMBLY INSTRUCTIONS

COASTER FINE FURNITURE



Fine Furniture for every stage of life

609455
Rocking Chair

ITEM: **609455**



ASSEMBLY INSTRUCTIONS

ASSEMBLY TIPS:

1. Remove hardware from box and sort by size.
2. Please check to see that all hardware and parts are present prior to start of assembly.
3. Please follow attached instructions in the same sequence as numbered to assure fast & easy assembly.



WARNING!









1. Don't attempt to repair or modify parts that are broken or defective. Please contact the store immediately.
2. This product is for home use only and not intended for commercial establishments.

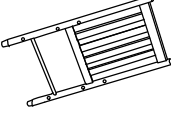





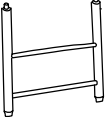

ASSEMBLY TIME

20 MINUTES

PARTS IDENTIFICATION

AN	BACK FRAME		1PC	EN	ROCKER		2PCS
BN	UPPER SIDE STRETCHER		2PCS	FN	SEAT		1PC
CN	LOWER SIDE STRETCHER		2PCS	GN	LEFT ARMREST		1PC
DN	FRONT LEG FRAME		1PC	HN	RIGHT ARMREST		1PC

HARDWARE IDENTIFICATION

1	PAN HEAD SCREW 4 (5x50mm - RBW)		2PCS	4	PAN HEAD SCREW 1 (4x20mm - RBW)		8PCS
2	PAN HEAD SCREW 3 (4x50mm - RBW)		4PCS	5	L BRACKET (15x15mm - RBW)		4PCS
3	PAN HEAD SCREW 2 (4x35mm - RBW)		14PCS	6	GLUE		1PC

NOTE:

Phillips head screw driver is required in the assembly process; however, manufacturer does not provide this item.

ITEM: **609455**

ASSEMBLY INSTRUCTIONS

STEP 1

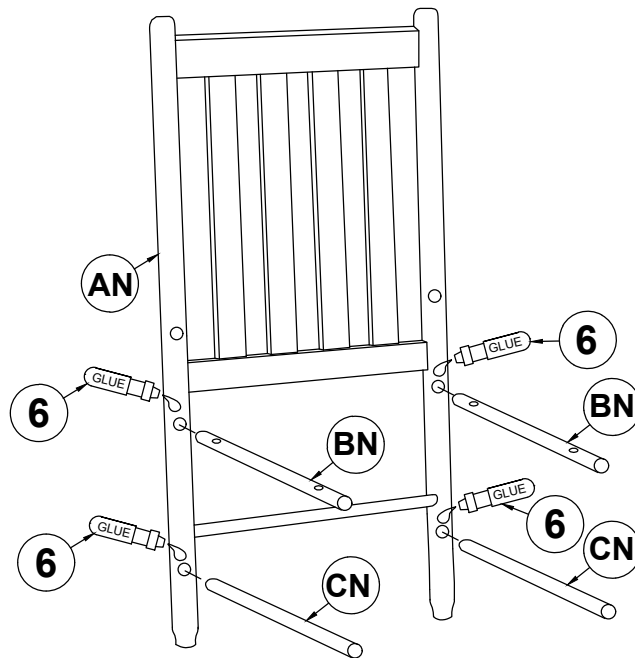

STEP 2

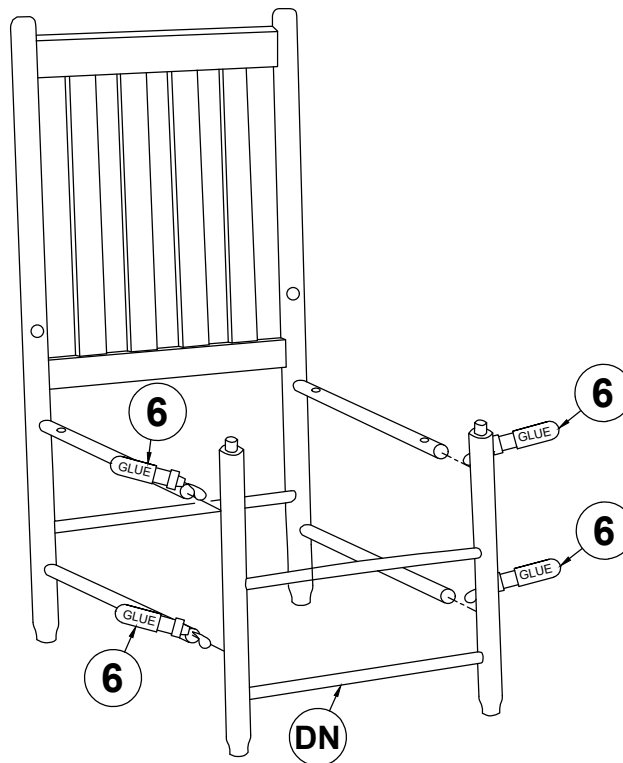

ITEM: **609455**

ASSEMBLY INSTRUCTIONS

STEP 3

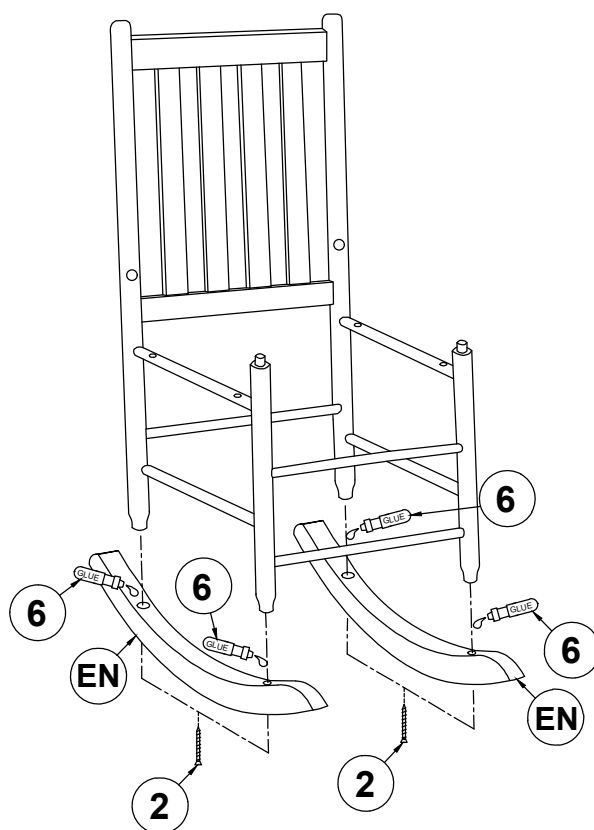

STEP 4

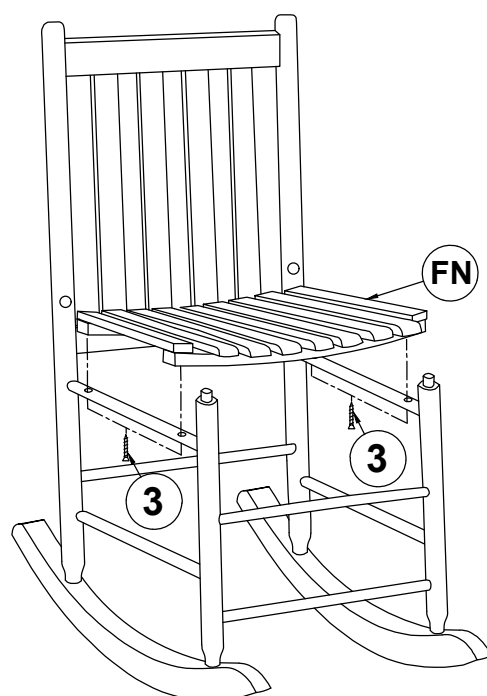

ITEM: **609455**



ASSEMBLY INSTRUCTIONS
STEP 5

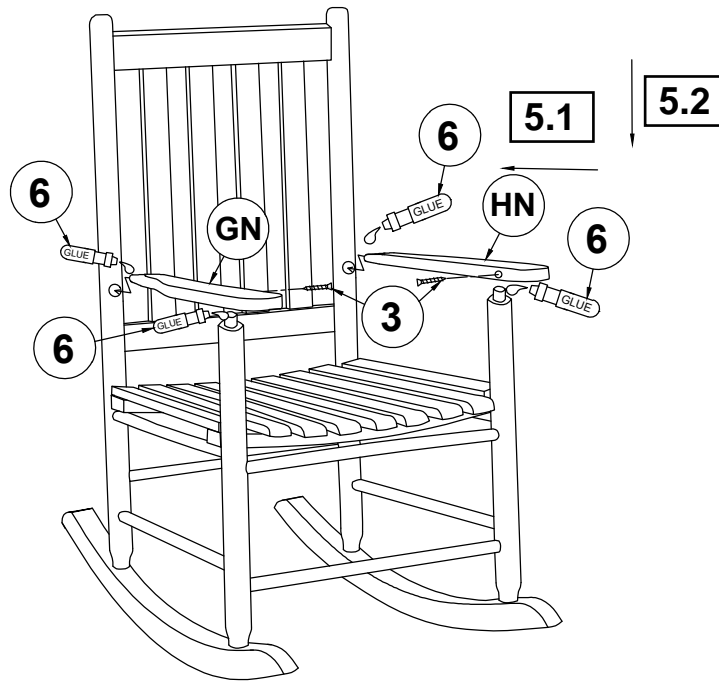

STEP 6

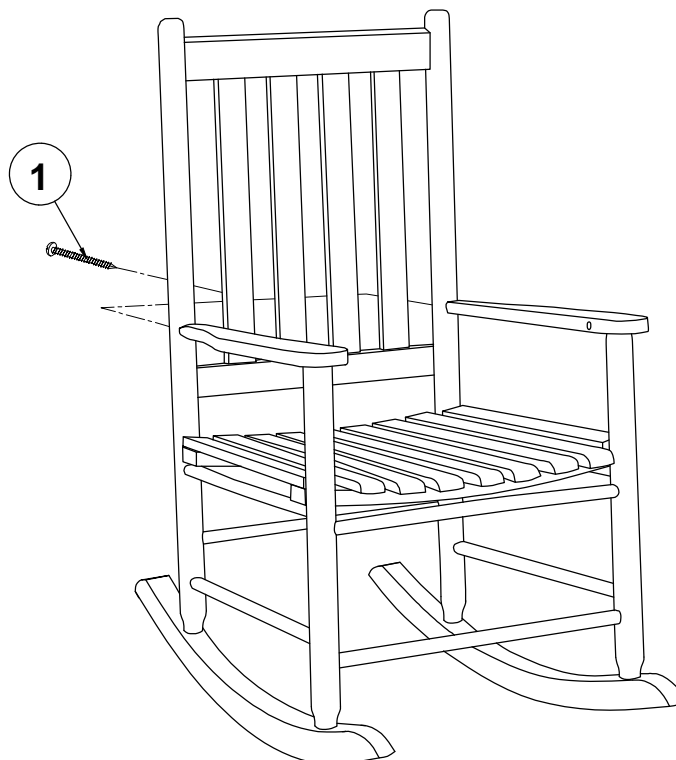

ITEM: **609455**



ASSEMBLY INSTRUCTIONS

STEP 7

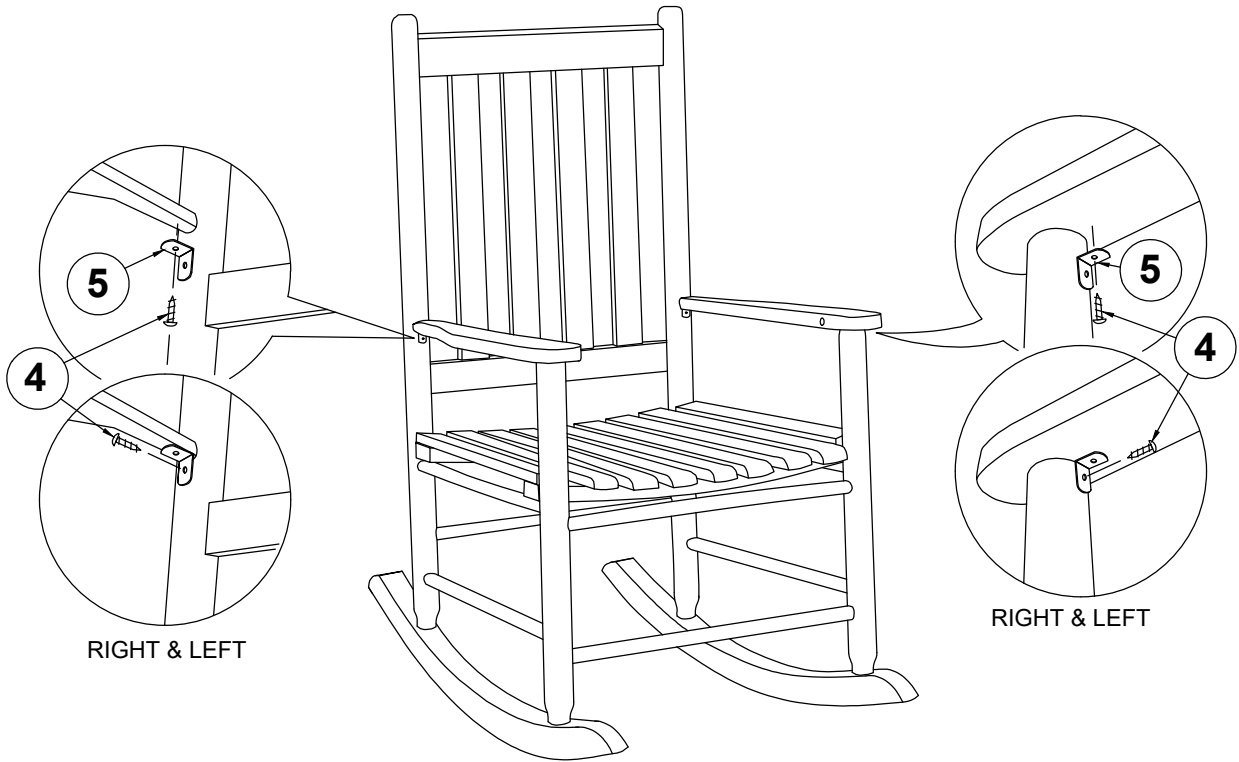

STEP 8
COMPLETE

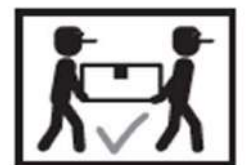
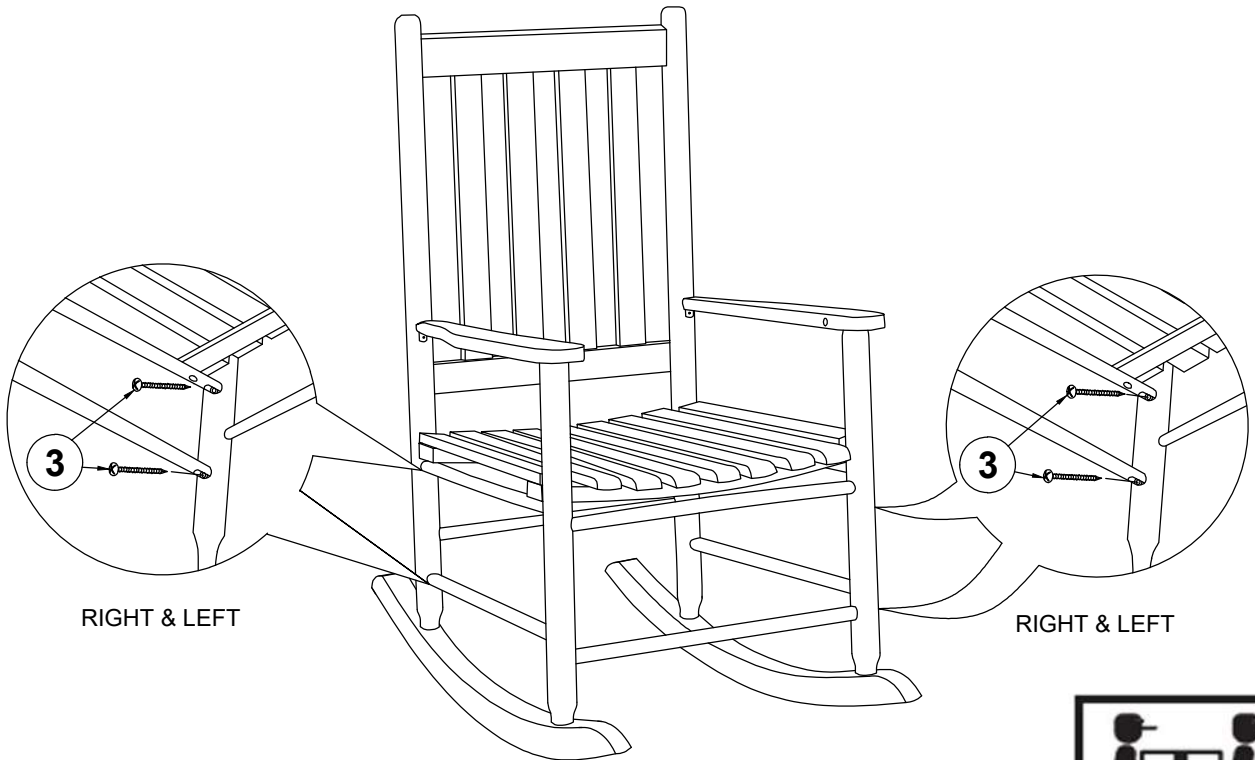

ITEM: 609455

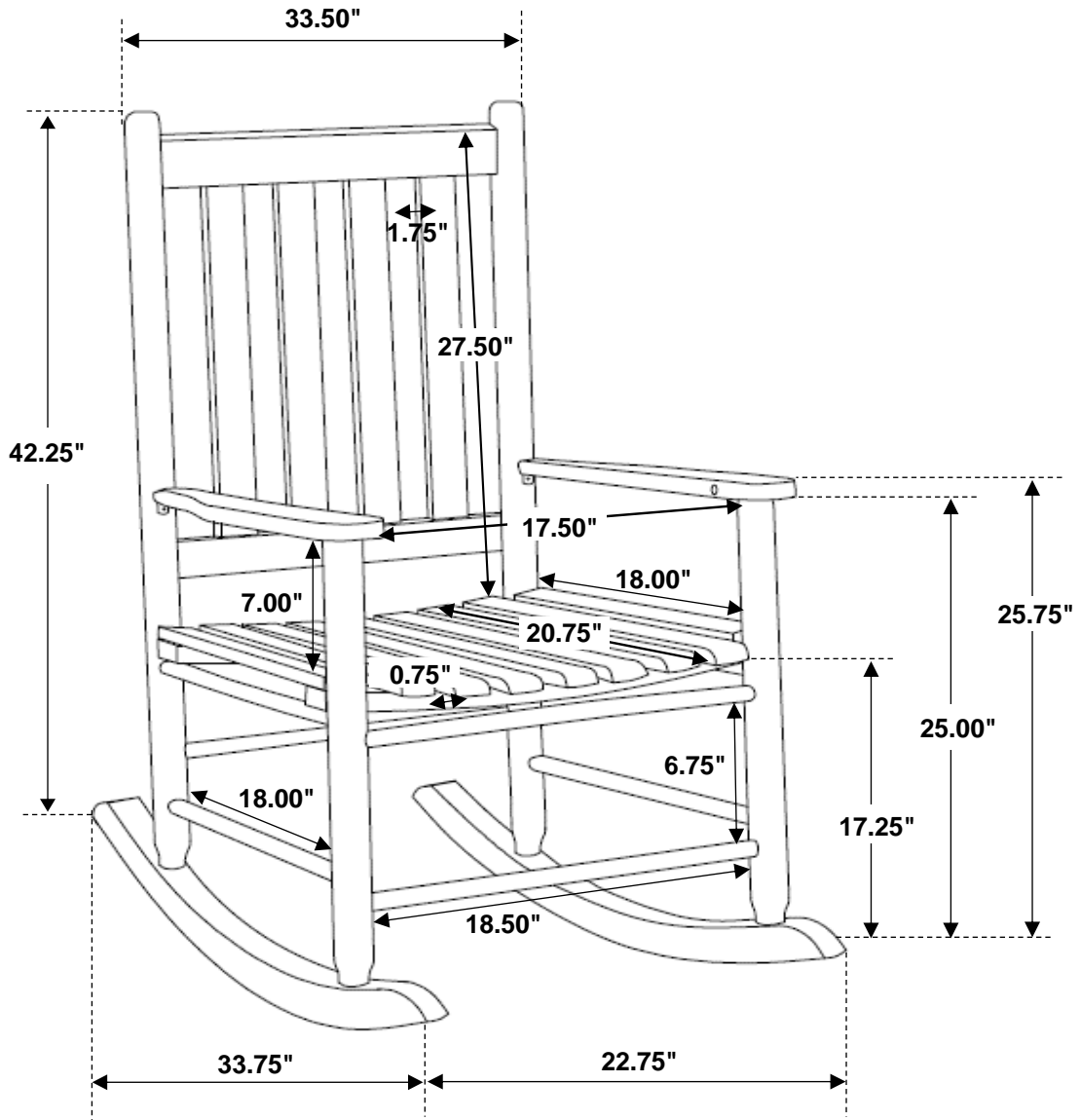

Note: Dimension tolerance $\pm 5\%$