



ASSEMBLY INSTRUCTIONS COASTER FINE FURNITURE



Fine Furniture for every stage of life

204191KW (B1&B2) **California King Bed**

REVISION 0 : 02/26/2017
REVISION 1 : 12/17/2017
REVISION 2 : 06/04/2019

ITEM: 204191KW(B1&B2)



ASSEMBLY INSTRUCTIONS

ASSEMBLY TIPS:

- 1 . Remove hardware from box and sort by size.
- 2 . Please check to see that all hardware and parts are present prior to start of assembly.
- 3 . Please follow attached instructions in the same sequence as numbered to assure fast & easy assembly.



WARNING !

- 1 . Don't attempt to repair or modify parts that are broken or defective. Please contact the store immediately.
- 2 . This product is for home use only and not intended for commercial establishment.



ASSEMBLY TIME

30 MINUTES

PARTS IDENTIFICATION

B1 (BOX 1)

A HEADBOARD PANEL

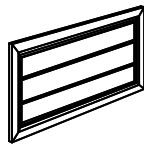

1PC

B RIGHT HEADBOARD LEG



1PC

C LEFT HEADBOARD LEG

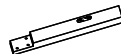

1PC

D FOOTBOARD

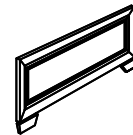

1PC

E BED SLAT



4PCS

F BED SLAT SUPPORT WITH LEVELER

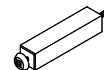

8PCS

B2 (BOX 2)

G BED RAIL



2PCS

HB 204191KW (B1)
(FROM BOX 1)
HEADBOARD COMPLETE

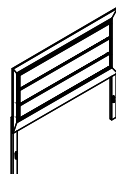

1PC

D 204191KW (B1)
(FROM BOX 1)
FOOTBOARD

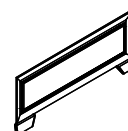

1PC

ITEM: 204191KW(B1&B2)



ASSEMBLY INSTRUCTIONS

ASSEMBLY TIPS:

- 1 . Remove hardware from box and sort by size.
- 2 . Please check to see that all hardware and parts are present prior to start of assembly.
- 3 . Please follow attached instructions in the same sequence as numbered to assure fast & easy assembly.



WARNING !

- 1 . Don't attempt to repair or modify parts that are broken or defective. Please contact the store immediately.
- 2 . This product is for home use only and not intended for commercial establishment.



ASSEMBLY TIME

30 MINUTES

HARDWARE IDENTIFICATION

Z-B1 (BOX1) - HARDWARE PACK IS LOCATED IN 204191KW (B1)

1 BOLT
(M6 x30mm - BLK)

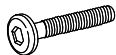

6PCS

4 FLAT HEAD SCREW
(M4 x 32mm - RBW)



8PCS

2 LOCK WASHER
(1/4" - BLK)



6PCS

5 SMALL ALLEN
WRENCH
(M4 x 65mm - BLK)



1PC

3 FLAT WASHER
(1/4" x13mm - BLK)



6PCS

6 BIG ALLEN
WRENCH
(M5 x 65mm - BLK)



1PC

NOTE:

Philips head screw driver in the assembly process ; however, manufacturer does not provide the item

ITEM: **204191KW(B1&B2)**
ASSEMBLY INSTRUCTIONS



STEP 1

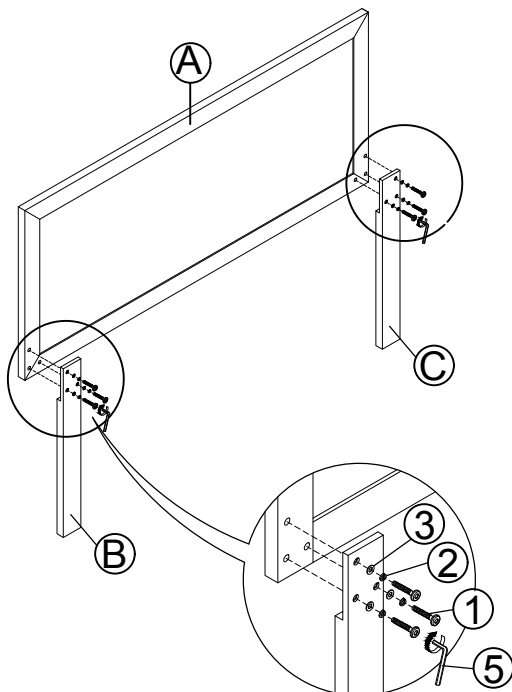

STEP 2

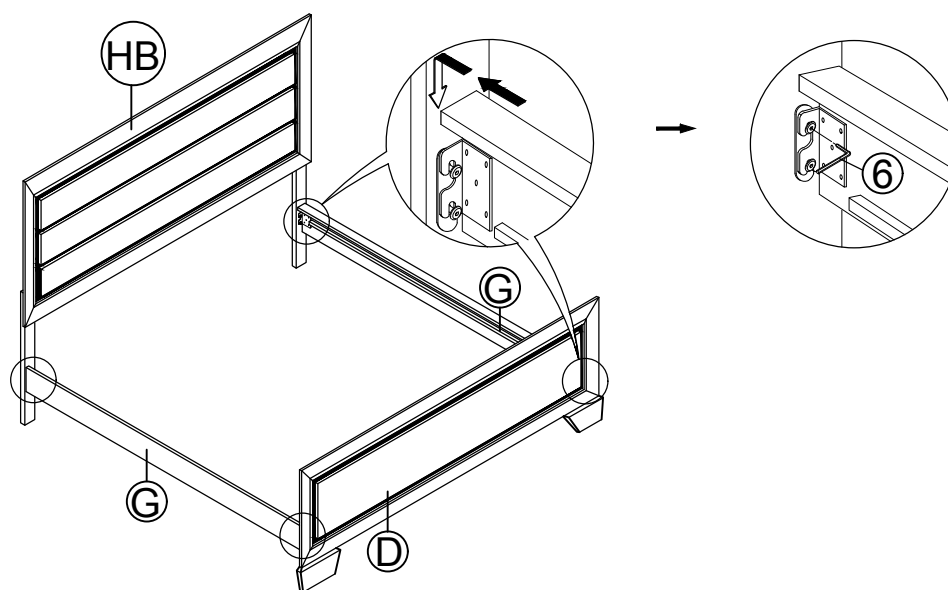

ITEM: **204191KW(B1&B2)**
ASSEMBLY INSTRUCTIONS



STEP 3

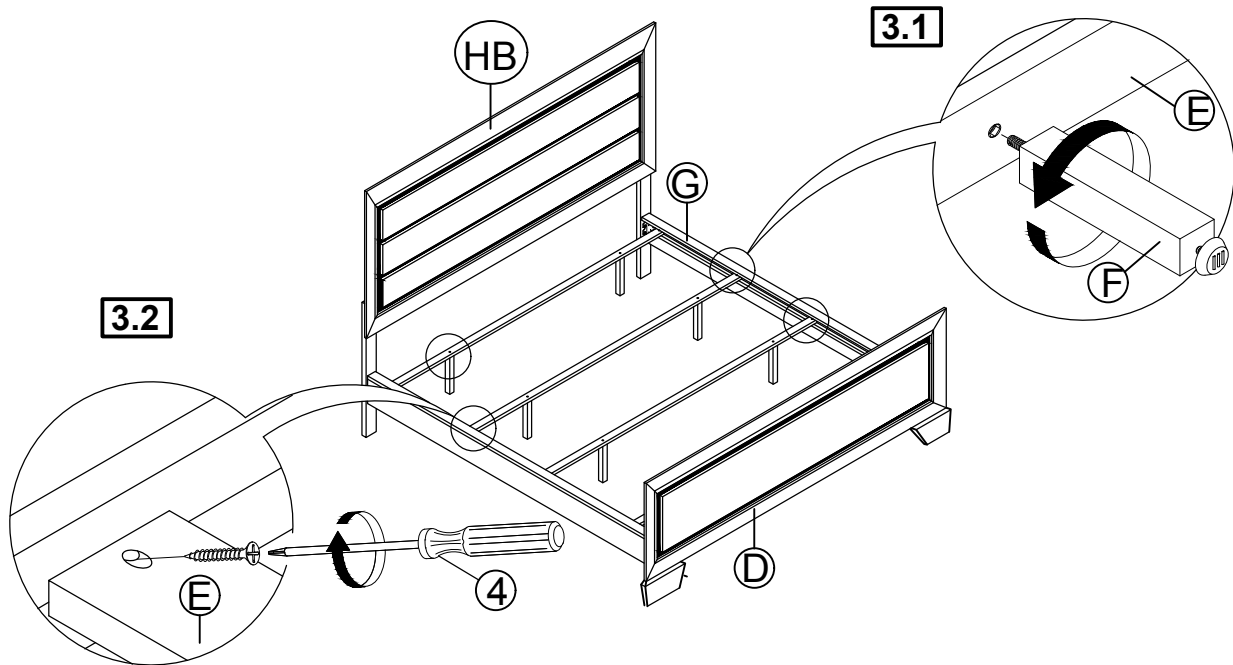

STEP 4
COMPLETE

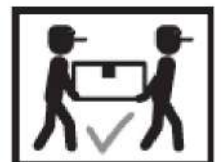
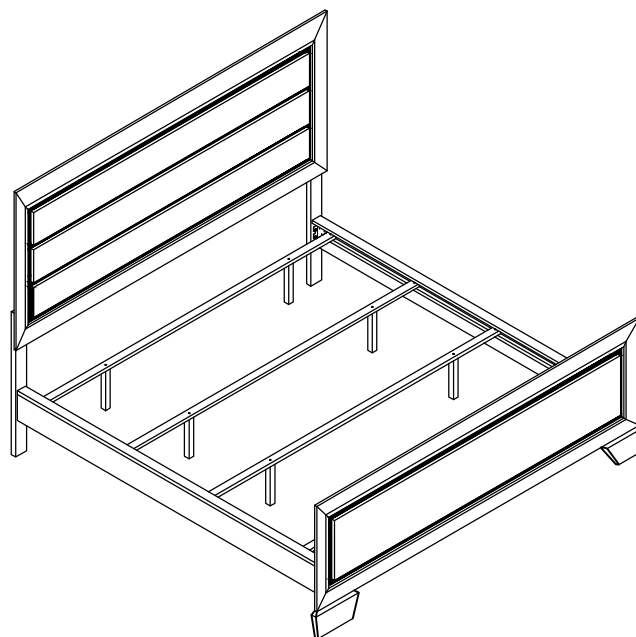

ITEM: **204191KW(B1&B2)**



Inner Size : 72.75"W X 86.50"D

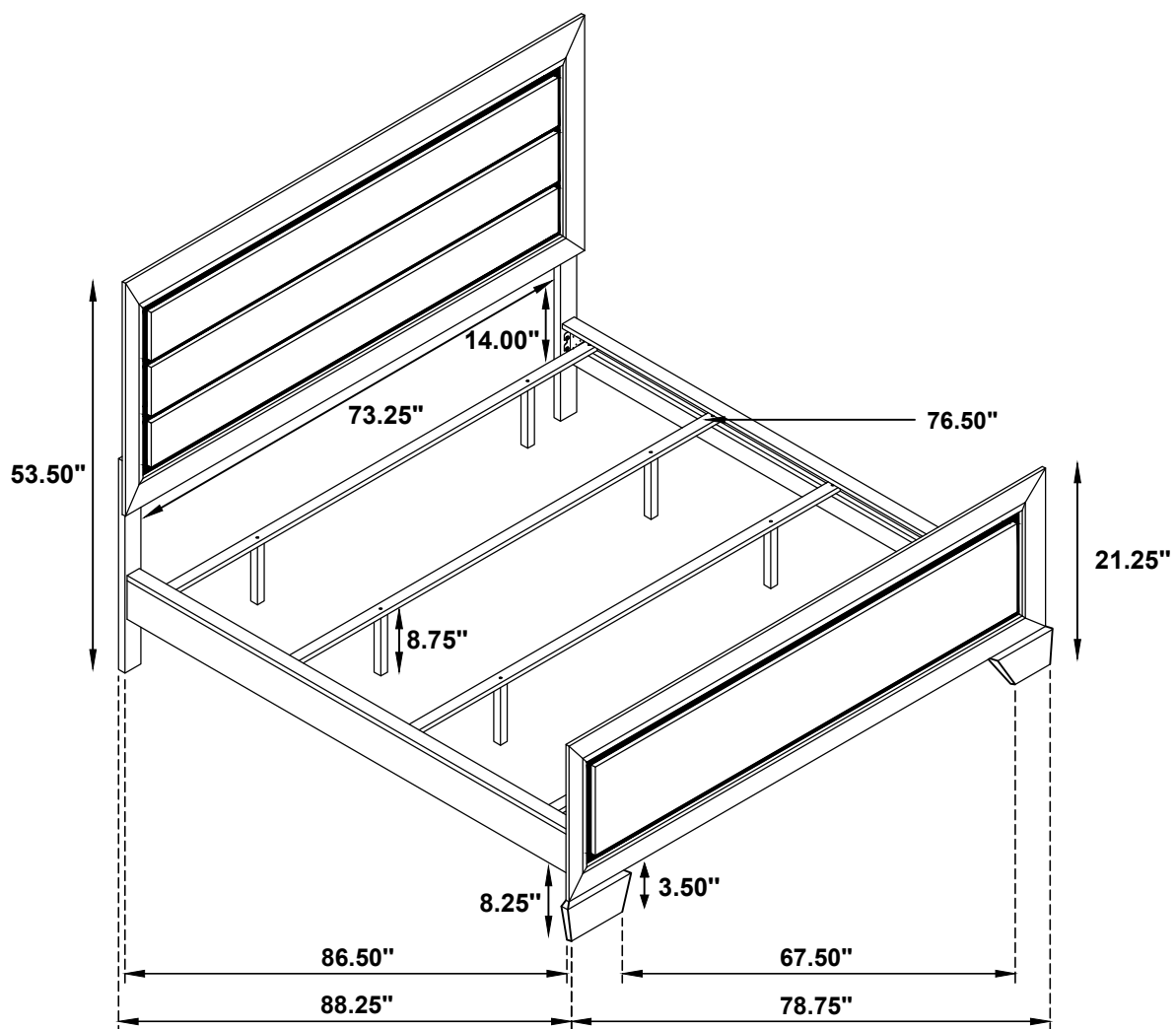

Note : Dimension tolerance $\pm 5\%$