

ASSEMBLY INSTRUCTIONS
COASTER FINE FURNITURE

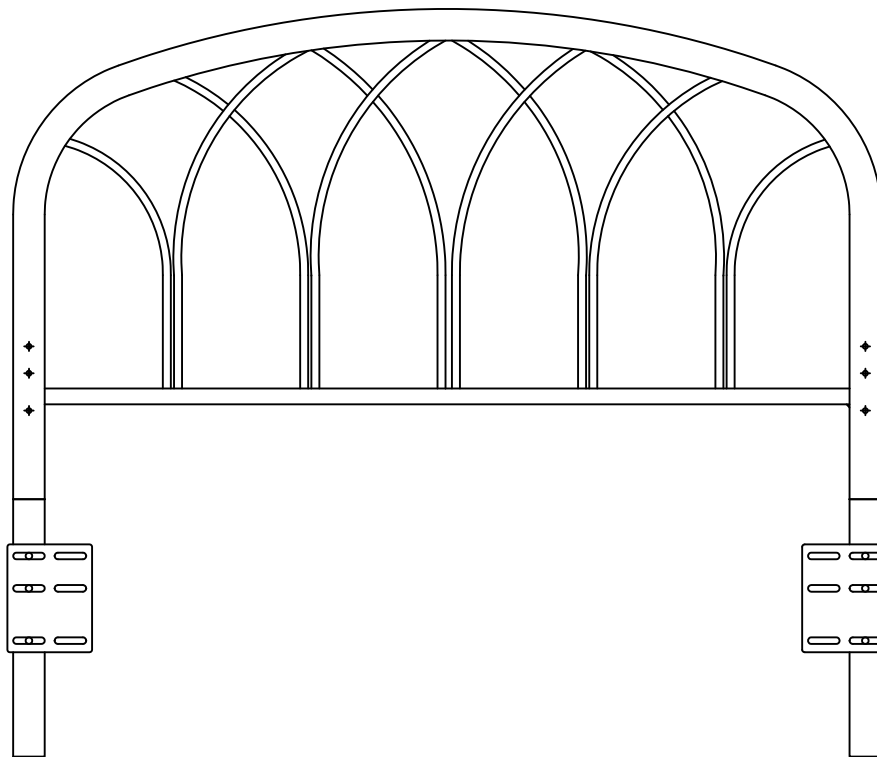

Fine Furniture for every stage of life

300184QF
Queen & Full Universal
Size Headboard Only

ITEM:300184QF



ASSEMBLY INSTRUCTIONS

ASSEMBLY TIPS:

1. Remove hardware from box and sort by size.
2. Please check to see that all hardware and parts are present prior to start of assembly.
3. Please follow attached instructions in the same sequence as numbered to assure fast & easy assembly.



WARNING !

1. Don't attempt to repair or modify parts that are broken or defective. Please contact the store immediately.
2. This product is for home use only and not intended for commercial establishment.

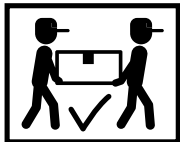

ASSEMBLY TIME

20 MINUTE

PARTS IDENTIFICATION

A HEADBOARD

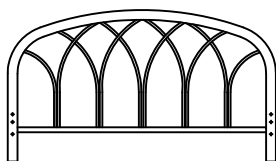

1PC

C ADJUSTING PLATE



2PCS

B SUPPORT LEG



2PCS

HARDWARE IDENTIFICATION

1 BOLT
(1/4"x2-3/4" - BLK)



4PCS

5 NUT
(ϕ 1/4"x8mm - BLK)



8PCS

2 BOLT
(1/4"x7/8" - BLK)



4PCS

6 PLASTIC END CAP
(ϕ 1-1/2" - BLK)



2PCS

3 WASHER
(ϕ 5/8" - BLK)



12PCS

7 ALLEN KEY
(4x22X60mm - BLK)



1PC

4 PLASTIC WASHER
(ϕ 1" - BLK)



8PCS

8 WRENCH
(11.3x12.5X55mm - WHT)



1PC

NOTE:

Phillips head screw driver is required in the assembly process; however, manufacturer does not provide this item.

ITEM: **300184QF**



ASSEMBLY INSTRUCTIONS

ASSEMBLY

Do not fully tighten all bolts until assembly is complete.
This will help all parts to assemble properly.

STEP 1:

60" ASSEMBLY INSTRUCTIONS

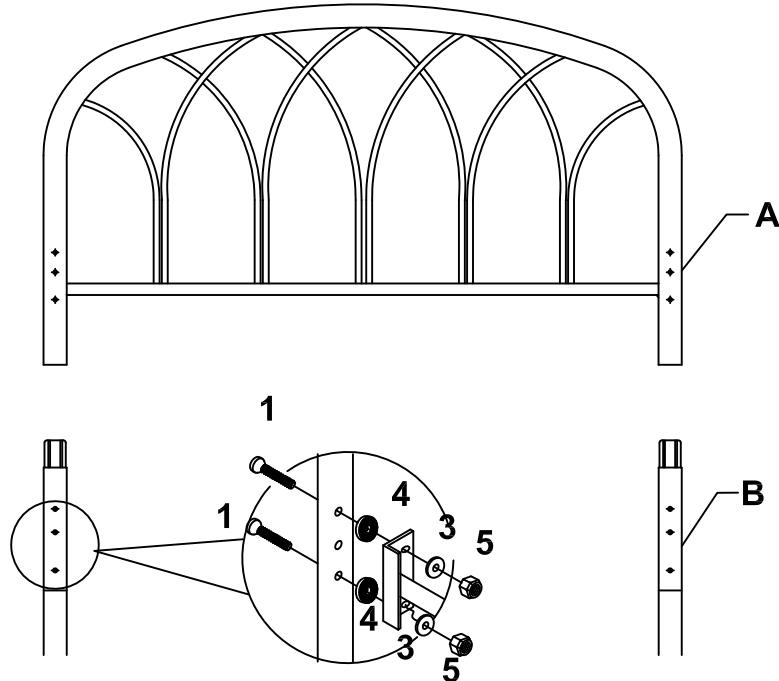

STEP 2:

54" ASSEMBLY INSTRUCTIONS

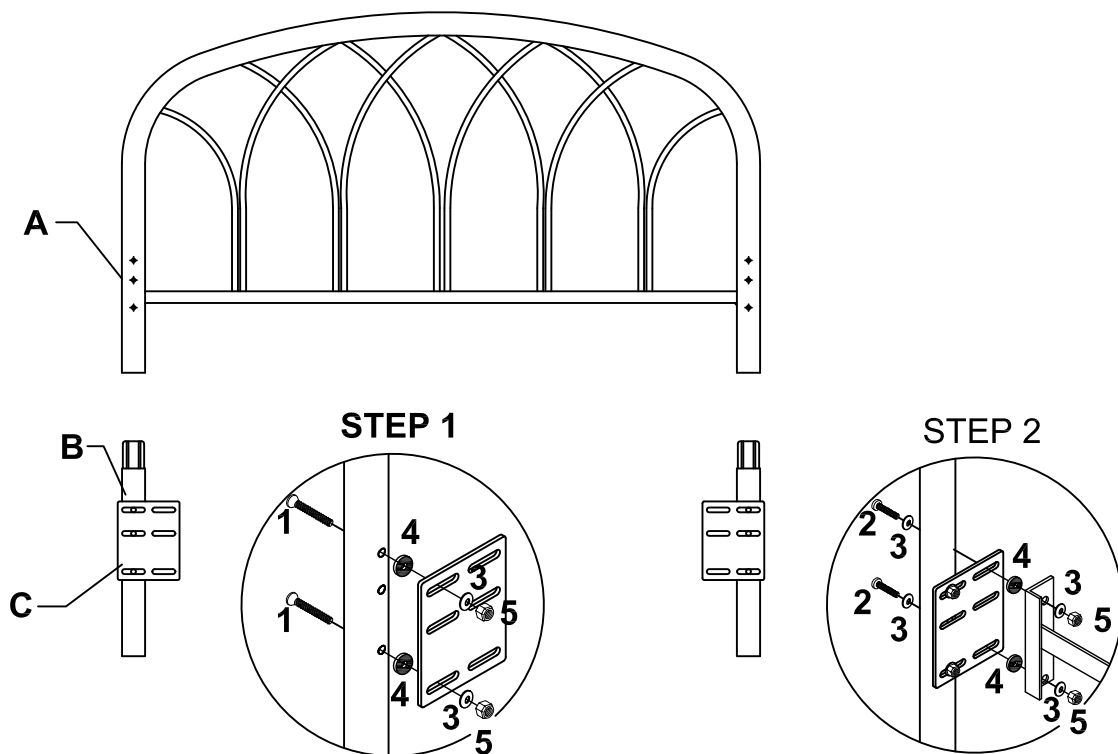

ITEM: **300184QF**

ASSEMBLY INSTRUCTIONS

STEP 3:

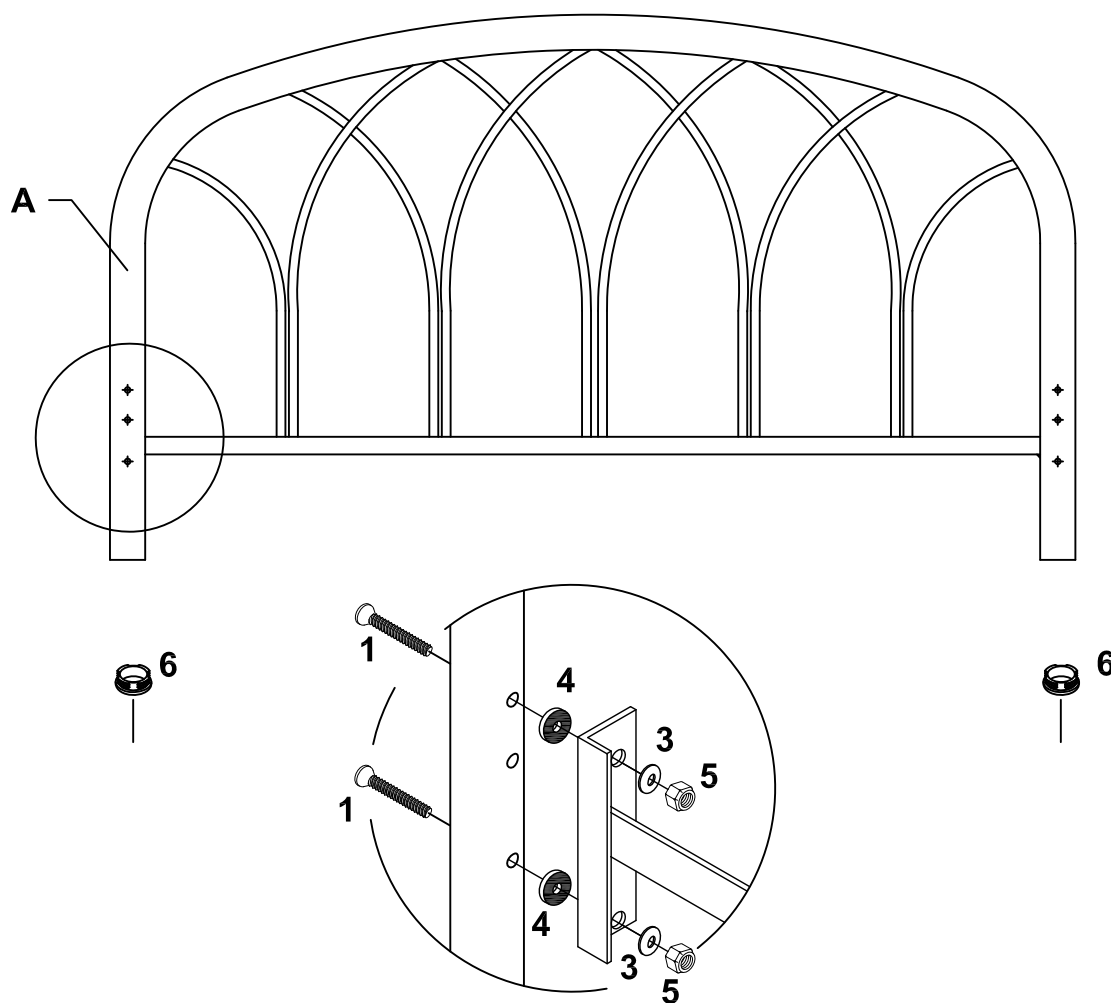

ITEM:300184QF

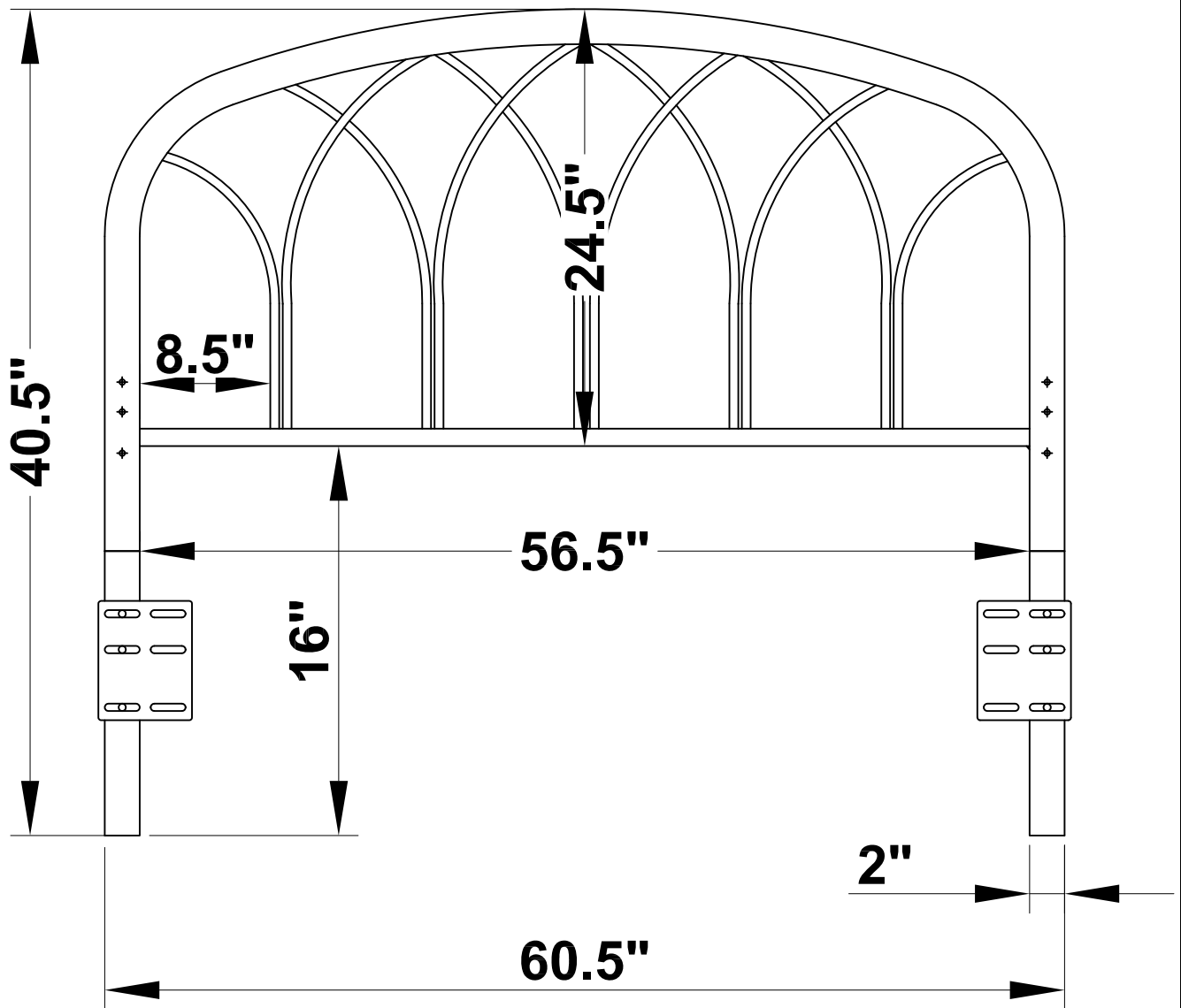

Note : Dimension tolerance $\pm 5\%$