

ASSEMBLY INSTRUCTIONS
COASTER FINE FURNITURE



Fine Furniture for every stage of life

902589
SERVING CART

REVISION 0 : 09/25/2017
REVISION 1 : 07/25/2019
REVISION 2 : 09/05/2022

ITEM:902589



ASSEMBLY INSTRUCTIONS

ASSEMBLY TIPS:

1. Remove hardware from box and sort by size.
2. Please check to see that all hardware and parts are present prior to start of assembly.
3. Please follow attached instructions in the same sequence as numbered to assure fast & easy assembly.



WARNING!

1. Don't attempt to repair or modify parts that are broken or defective. Please contact the store immediately.
2. This product is for home use only and not intended for commercial establishments.

ASSEMBLY TIME 45 MINUTES

PARTS IDENTIFICATION

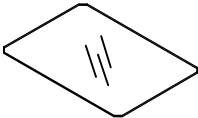
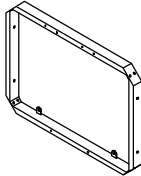
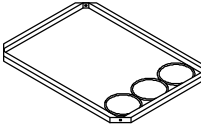
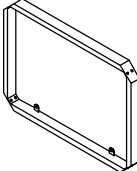
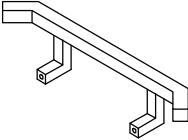
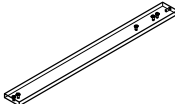
A	SHELF GLASS		2PCS
B	TOP FRAME		1PC
C	WINE FRAME		1PC
D	BOTTOM FRAME		1PC
E	HANDLE		2PCS
F	SUPPORT PANEL		4PCS

ITEM:902589









ASSEMBLY INSTRUCTIONS

PARTS IDENTIFICATION

G	WINE GLASS RACK		2CPS
---	-----------------	---	------

HARDWARE IDENTIFICATION

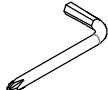
1	SHORT BOLT (1/4" x 12mm SR)		20PCS
2	LONG BOLT (1/4" x 38mm SR)		4PCS
3	SCREW (3/16" x 12mm)		6PCS
4	NUT (1/4")		20PCS
5	SUCTION CUP (Ø19 x 9mm)		8PCS
6	WHEEL-LOCK (1/4" x 15mm)		2PCS
7	WHEEL (1/4" x 15mm)		2PCS
8	ALLEN WRENCH (4mm)		1PC

ITEM:902589



ASSEMBLY INSTRUCTIONS

STEP 1 Do not tighten until each step is completed or instructed.

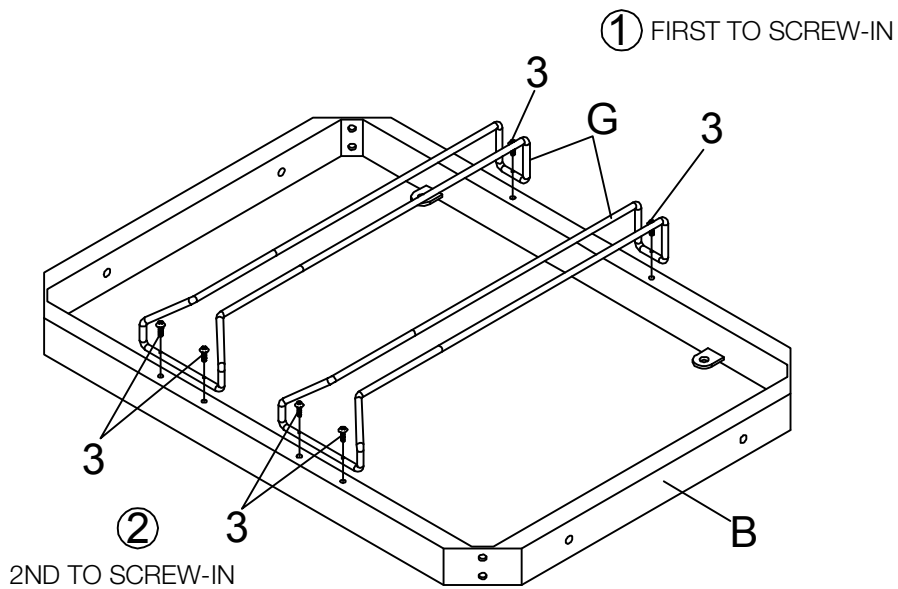

NOTE: STEP #① AND THEN STEP # ②
DO NOT FULLY TIGHTEN THE SCREWS
UNTIL ALL IN

ITEM: 902589

ASSEMBLY INSTRUCTIONS

STEP 2

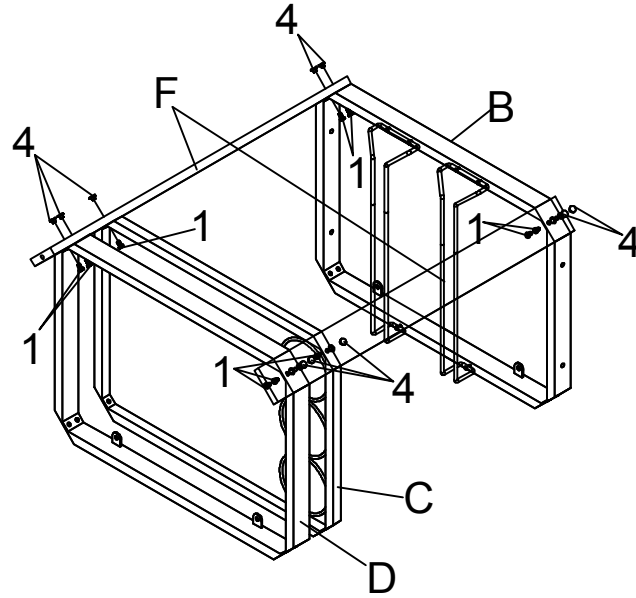

STEP 3

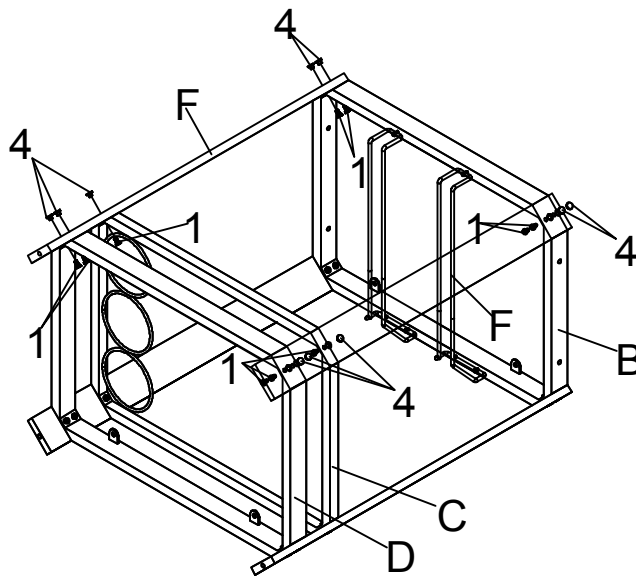

ITEM: 902589

ASSEMBLY INSTRUCTIONS

STEP 4

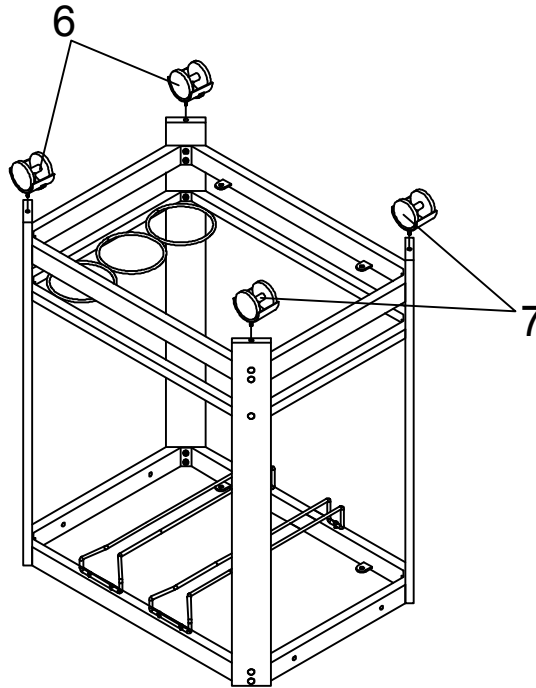

STEP 5

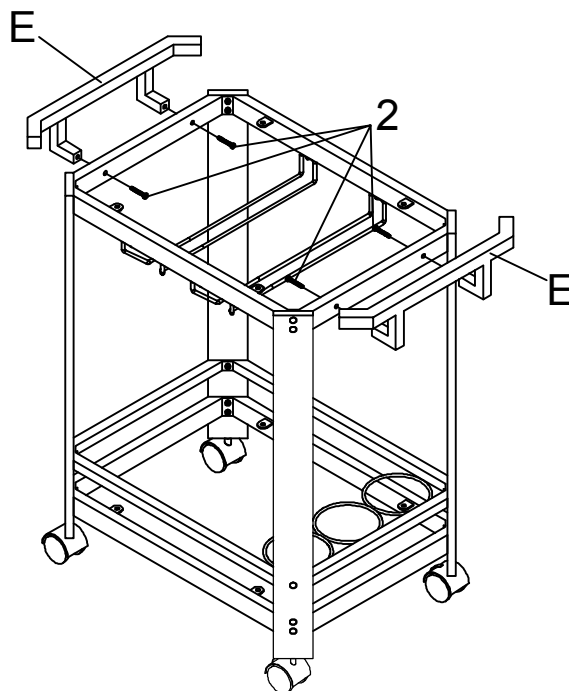

ITEM: 902589

ASSEMBLY INSTRUCTIONS

STEP 6

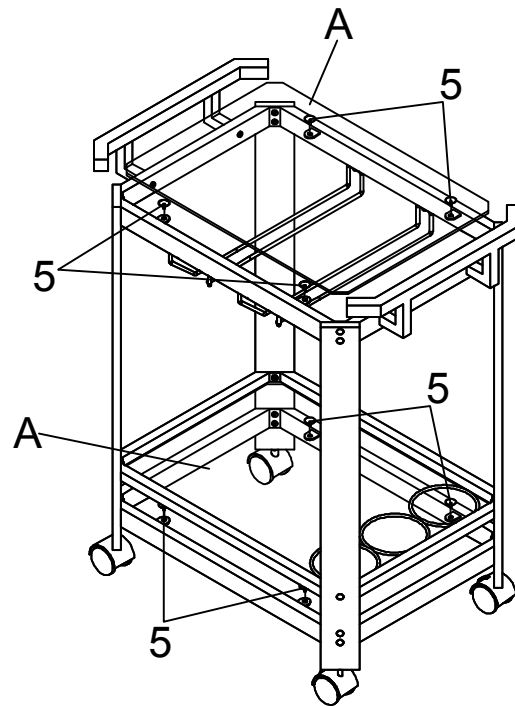

STEP 7 COMPLETE

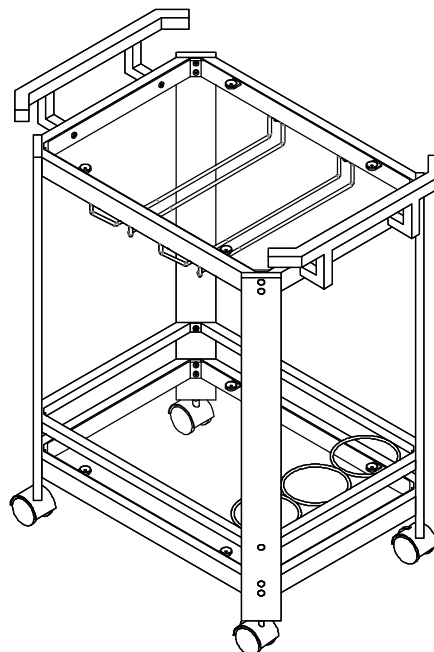

How to clean Acrylic product:
Using a dry soft microfiber cloth, lightly brush off any dust.
For additional care, dampen the cloth with warm water.
For deepest cleaning, use an Acrylic cleaner.

ITEM:902589

ASSEMBLY INSTRUCTIONS



Product Size : 723 X 438 X 889 H (MM)

Product Size : 28 1/2" X 17 1/4" X 35"

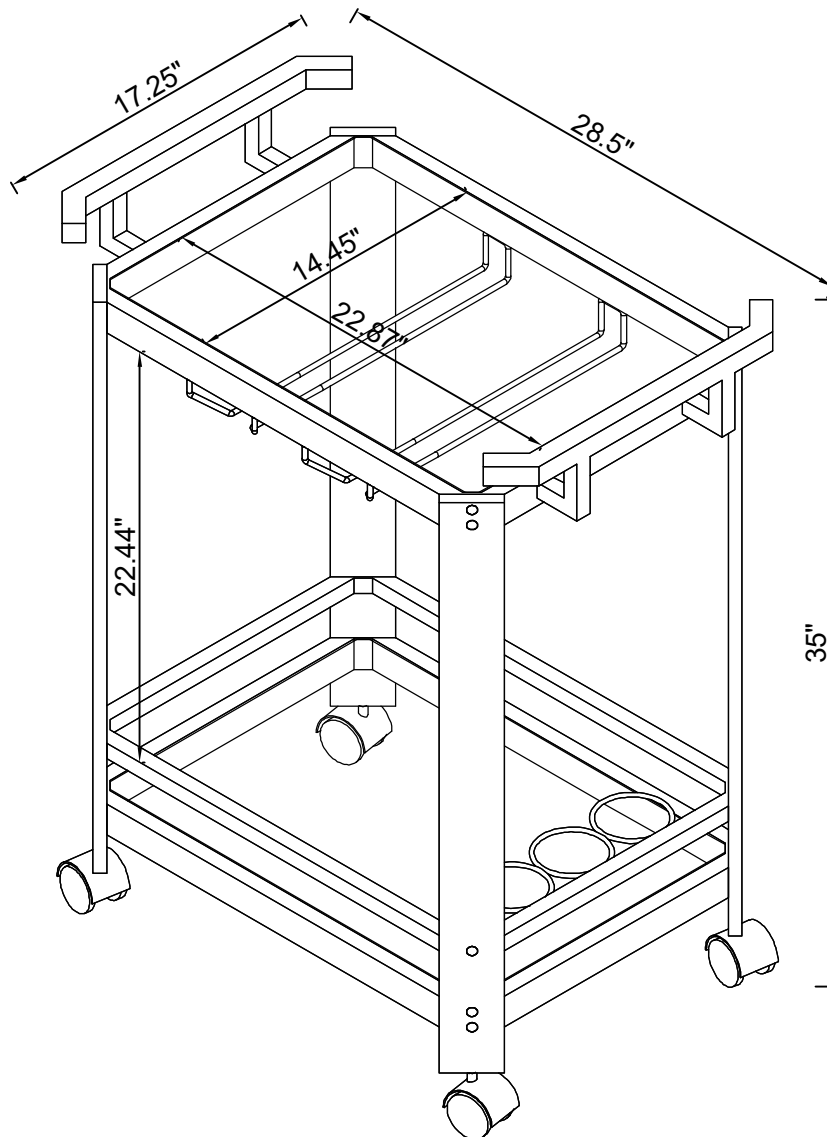

Note : Dimension tolerance $\pm 5\%$