

ASSEMBLY INSTRUCTIONS
COASTER FINE FURNITURE



Fine Furniture for every stage of life

722968
Nesting Coffee Table

REVISION 0 : 05/18/2020
REVISION 0 : 09/05/2023

ITEM: 722968 (B1-B2)



ASSEMBLY INSTRUCTIONS

ASSEMBLY TIPS:

1. Remove hardware from box and sort by size.
2. Please check to see that all hardware and parts are present prior to start of assembly.
3. Please follow attached instructions in the same sequence as numbered to assure fast & easy assembly.



WARNING!

1. Don't attempt to repair or modify parts that are broken or defective. Please contact the store immediately.
2. This product is for home use only and not intended for commercial establishments.



ASSEMBLY TIME

30 MINUTES

PARTS IDENTIFICATION

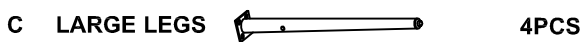
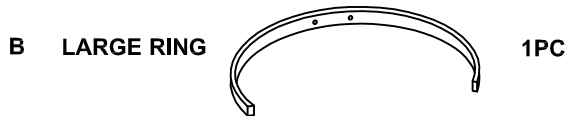
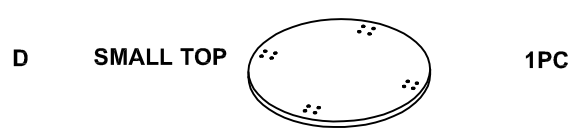
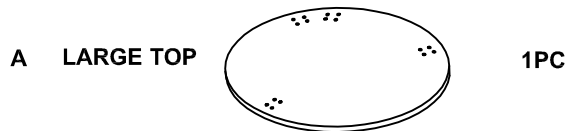

HARDWARE IDENTIFICATION

Z-B1 (BOX1) - HARDWARE PACK IS LOCATED IN 722968 (B1)

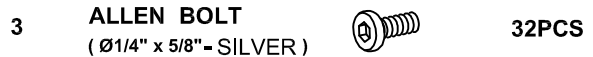

ITEM: 722968 (B1-B2)



ASSEMBLY INSTRUCTIONS

STEP 1

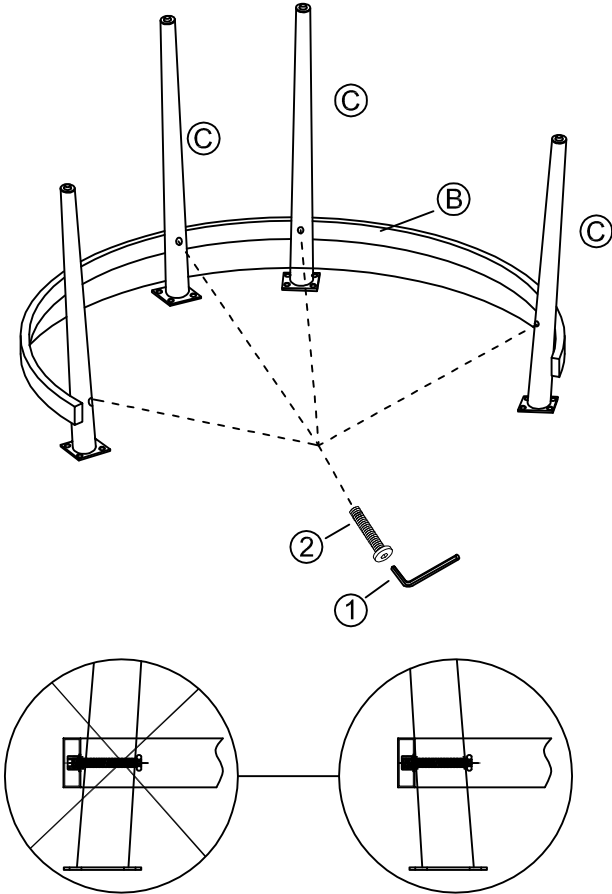

STEP 2

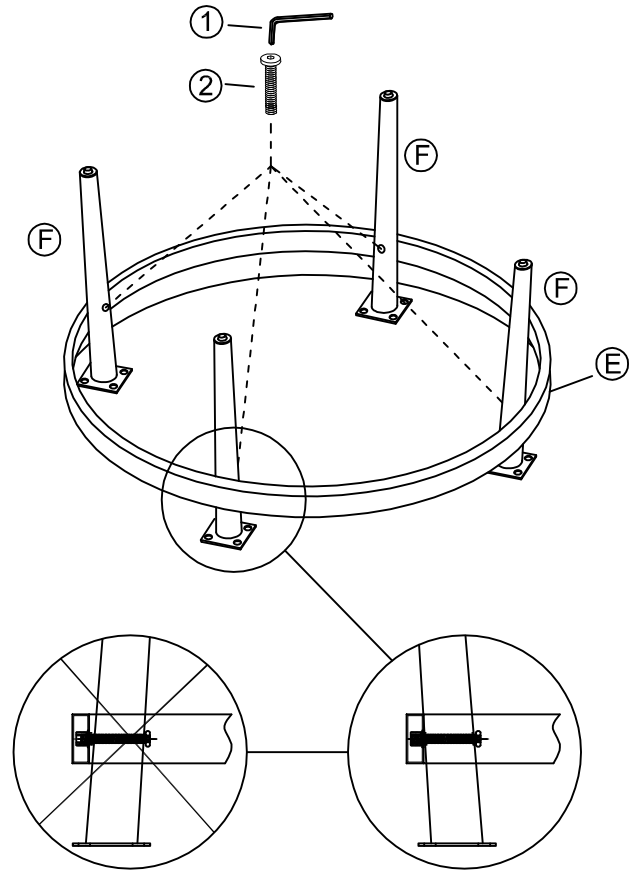

STEP 3

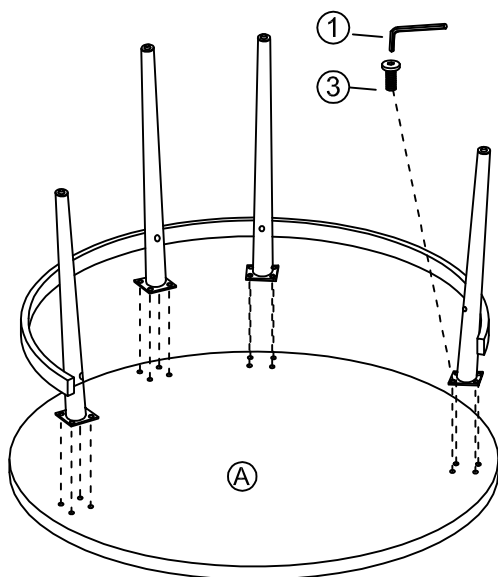

STEP 4

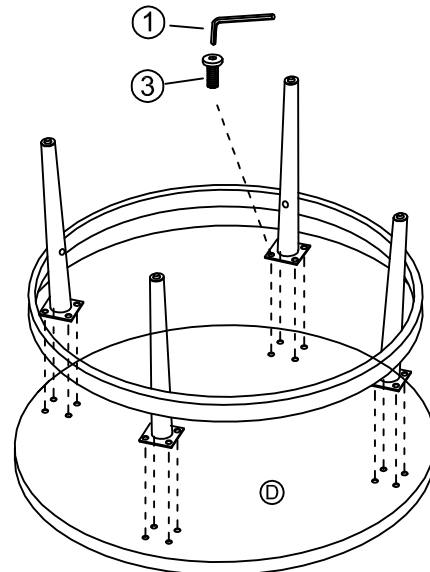

ITEM: **722968 (B1-B2)**



ASSEMBLY INSTRUCTIONS

STEP 5

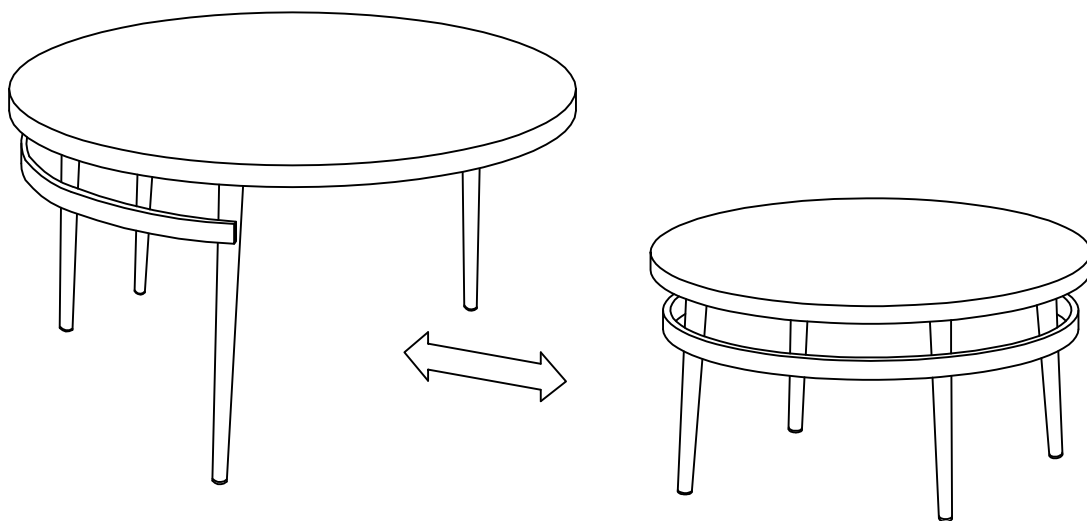

STEP 6
COMPLETE

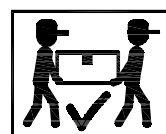
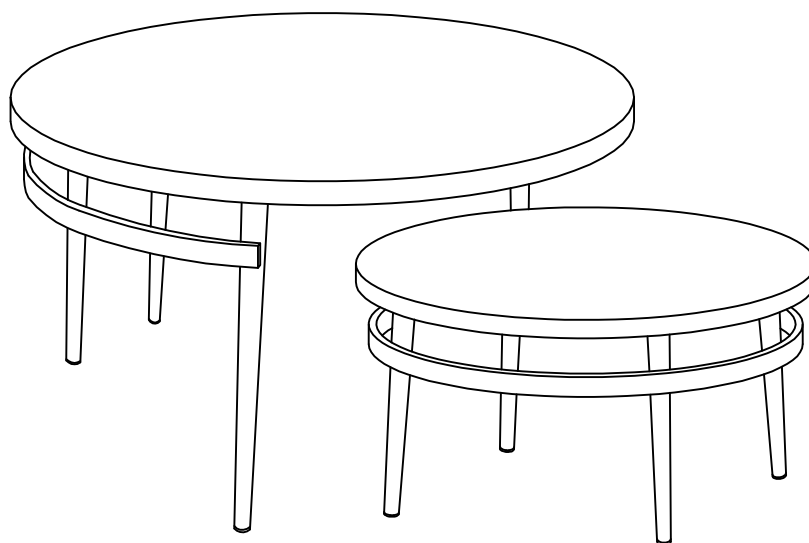

ITEM: 722968 (B1-B2)

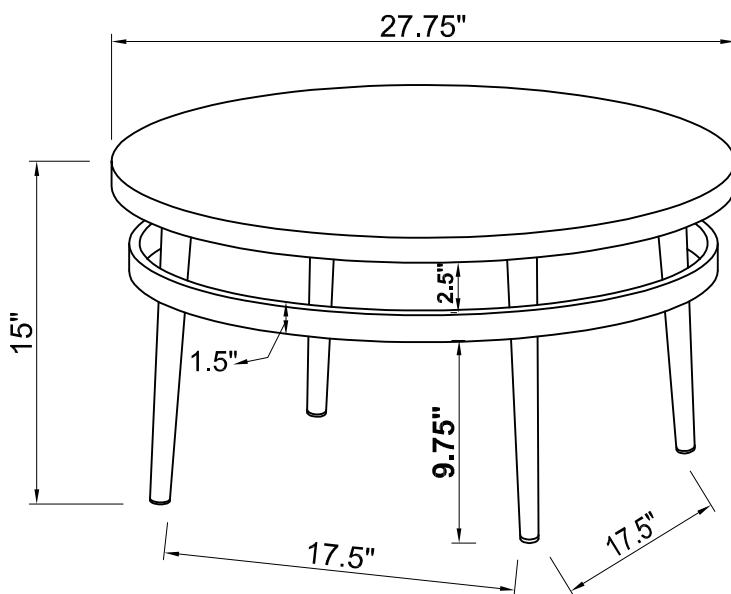
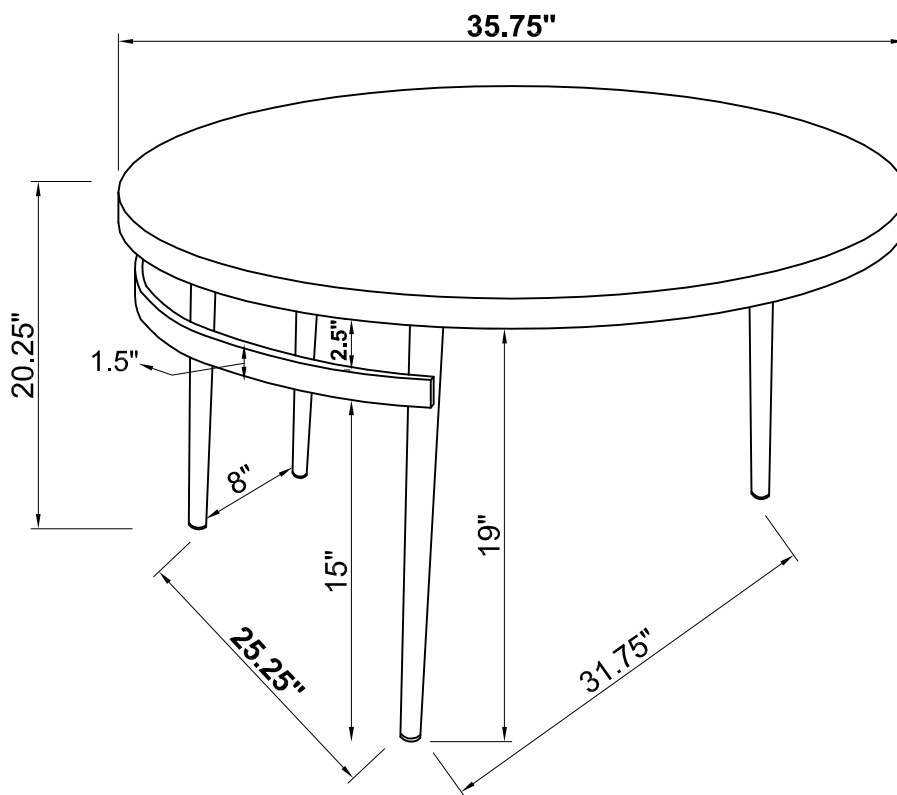

Note : Dimension tolerance $\pm 5\%$