

ASSEMBLY INSTRUCTIONS
COASTER FINE FURNITURE



Fine Furniture for every stage of life

192090
4Pc Counter Height Set

ITEM: 192090



ASSEMBLY INSTRUCTIONS

ASSEMBLY TIPS :

1. Remove hardware from box and sort by size.
2. Please check to see that all hardware and parts are present prior to start of assembly.
3. Please follow attached instructions in the same sequence as numbered to assure fast & easy assembly.



WARNING !



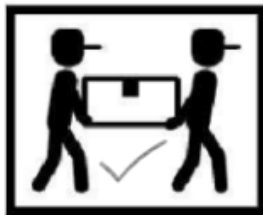





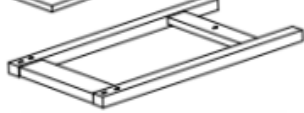

1. Don't attempt to repair or modify parts that are broken or defective. Please contact the store immediately.
2. This product is for home use only and not intended for commercial establishments.

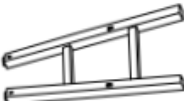

ASSEMBLY TIME

50 MINUTES

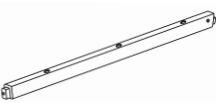
PARTS IDENTIFICATION

A	TABLE TOP		1PC
B	TABLE LEG FRAME		2PCS
C	TABLE APRON		2PCS
D	TABLE TRESTLE BAR		1PC
E	STOOL SEAT		2PCS
F	STOOL LEG FRAME		4PCS
G	STOOL FRONT & BACK LOWER STRETCHER		4PCS
H	BENCH SEAT		1PC
I	BENCH LEG FRAME		2PCS
J	BENCH FRONT & BACK STRETCHER		2PCS
K	BENCH FRONT & BACK LOWER STRETCHER		2PCS

ITEM: 192090



ASSEMBLY INSTRUCTIONS

ASSEMBLY TIPS :

1. Remove hardware from box and sort by size.
2. Please check to see that all hardware and parts are present prior to start of assembly.
3. Please follow attached instructions in the same sequence as numbered to assure fast & easy assembly.





WARNING !

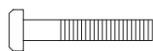

1. Don't attempt to repair or modify parts that are broken or defective. Please contact the store immediately.
2. This product is for home use only and not intended for commercial establishments.

HARDWARE IDENTIFICATION



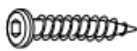

TABLE

1	ALLEN WRENCH (M4 x 110MM - BLK)		1PC
2	BOLT (M6 x 50MM - RBW)		16PCS
3	LOCK WASHER (1/4" - BLK)		16PCS
4	FLAT WASHER (M6 x 13MM - RBW)		16PCS

STOOL

5	HEX HEAD SCREW (M7 x 35MM - RBW)		8PCS
6	PAN HEAD SCREW (#8 x 1 1/2" -BLK)		8PCS
7	WOOD PLUG (Ø14.5 x9MM)		8PCS

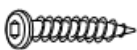
BENCH

8	BOLT (M6 x 50MM - RBW)		6PCS
9	LOCK WASHER (1/4" - BLK)		6PCS
10	FLAT WASHER (M6 x 13MM - RBW)		6PCS
11	HEX HEAD SCREW (M7 x 35MM - RBW)		8PCS
12	WOOD PLUG (Ø14.5 x9MM)		8PCS

ITEM: **192090**

ASSEMBLY INSTRUCTIONS
COUNTER TABLE



STEP 1

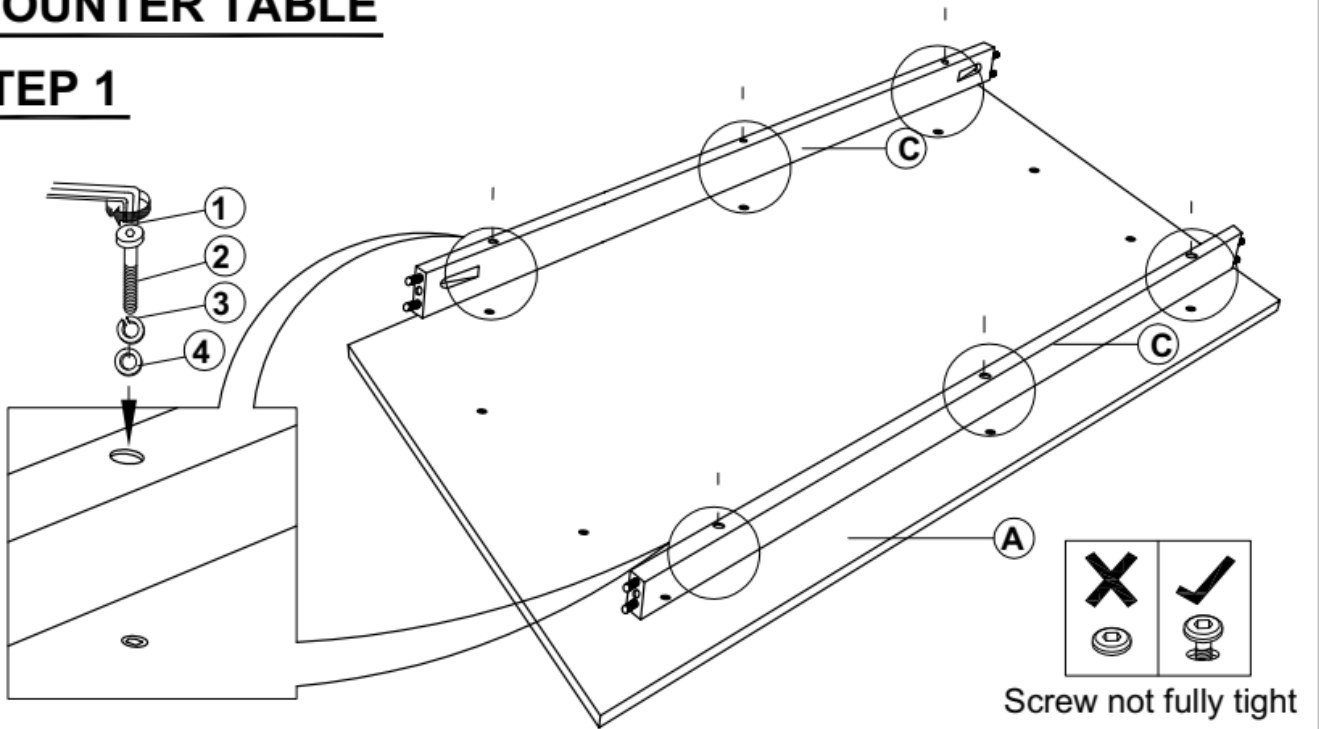

STEP 2

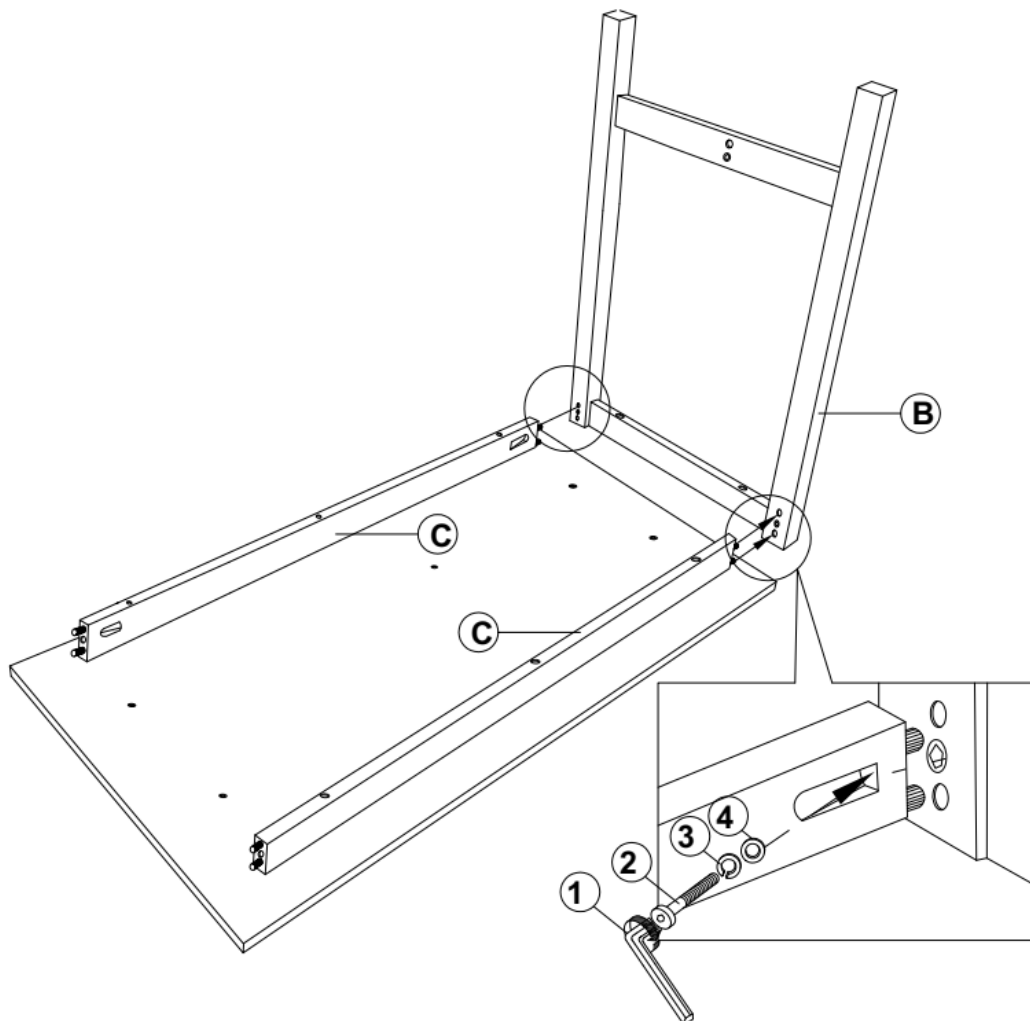

ITEM: **192090**

ASSEMBLY INSTRUCTIONS



STEP 3

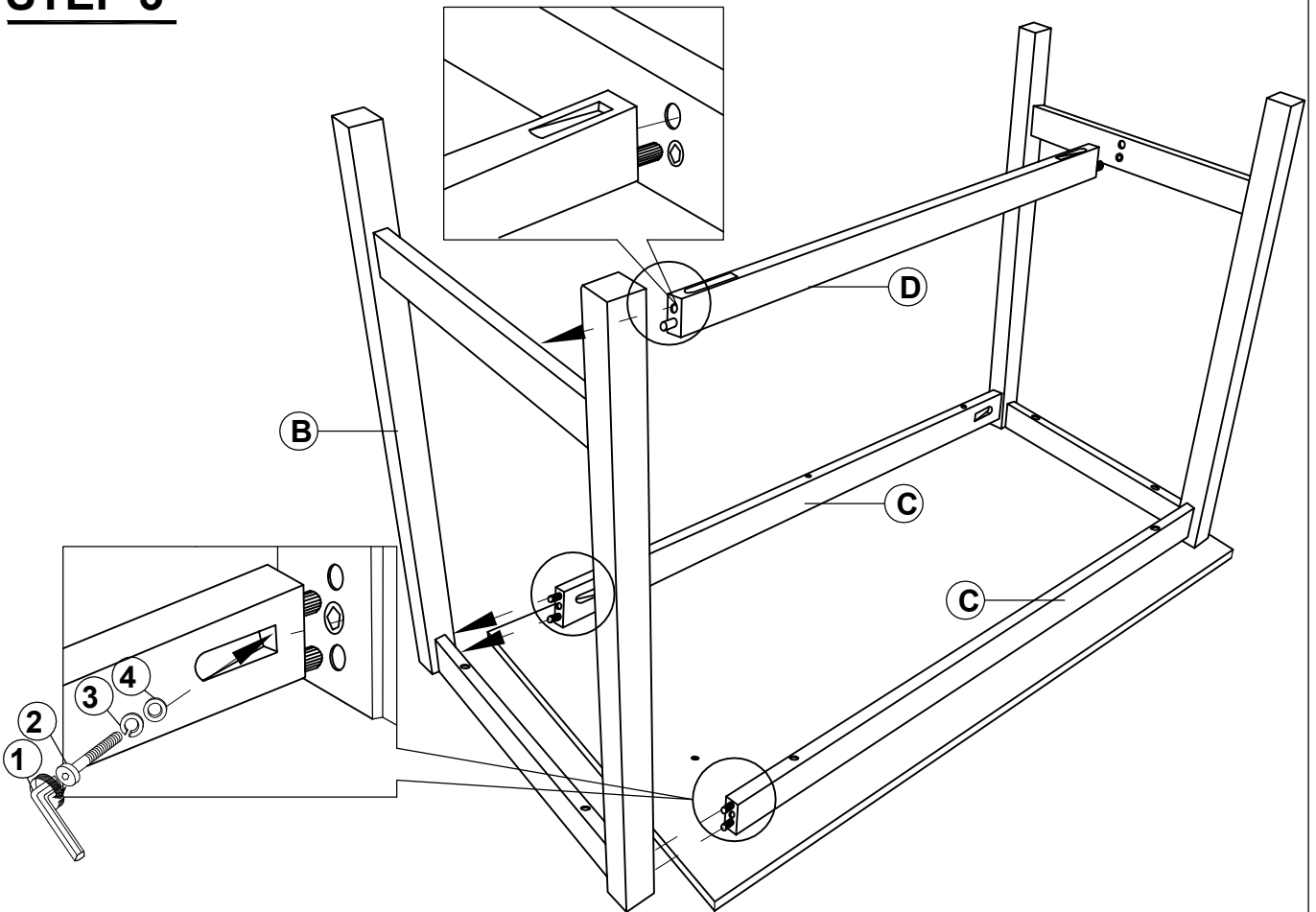

STEP 4

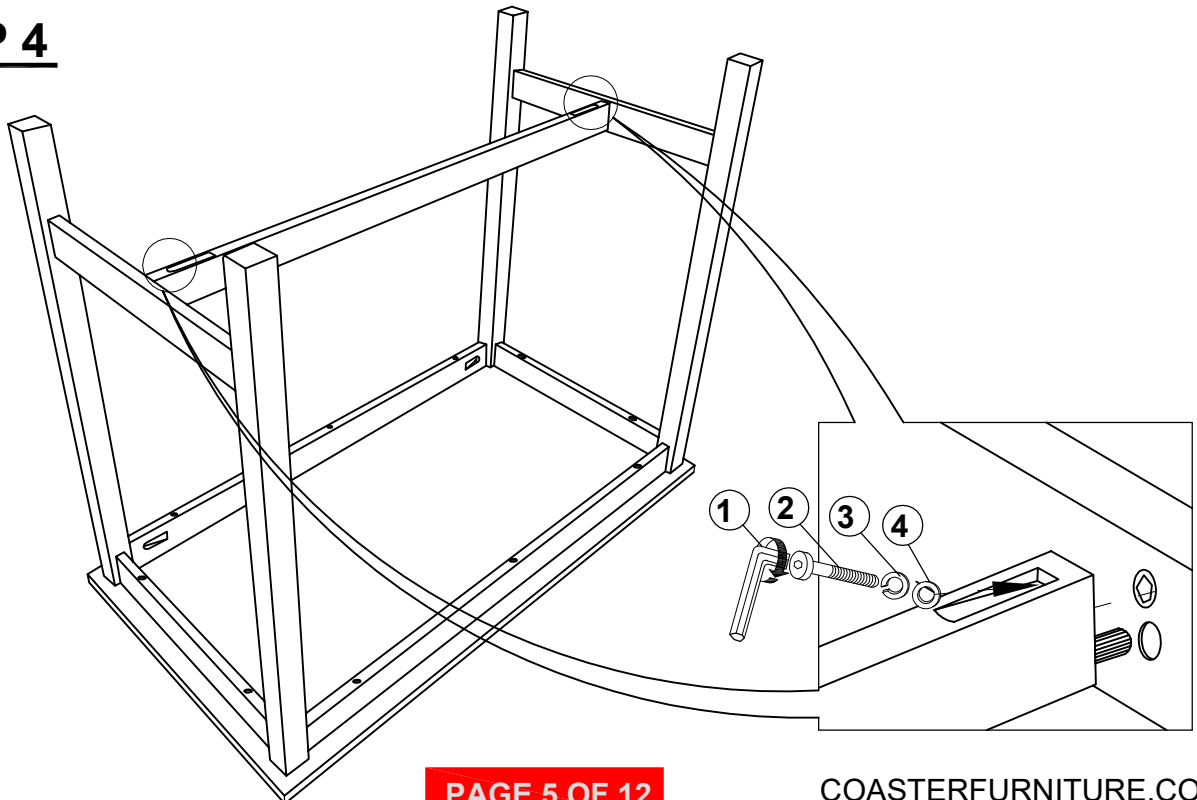

ITEM: **192090**

ASSEMBLY INSTRUCTIONS

STEP 5

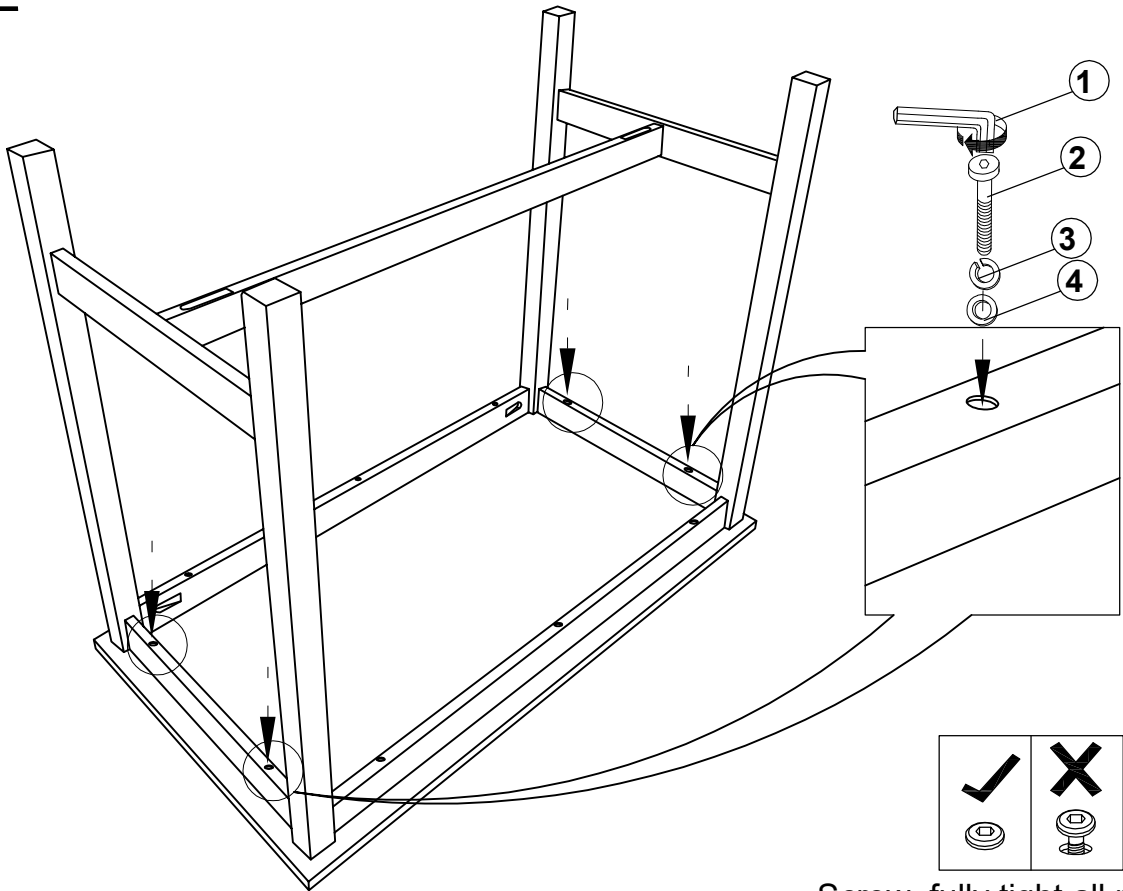

Screw fully tight all parts

STEP 6

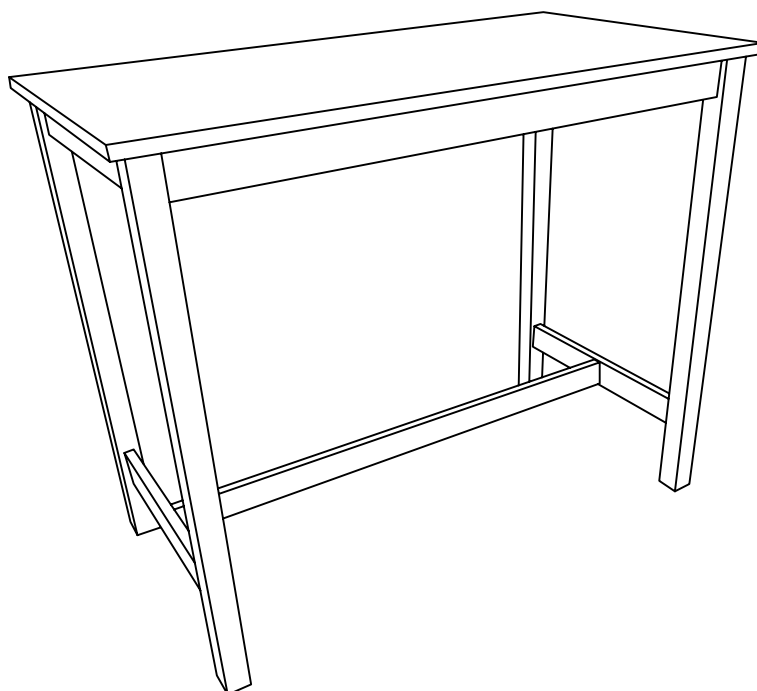

ITEM: **192090**

ASSEMBLY INSTRUCTIONS

STOOL

STEP 7

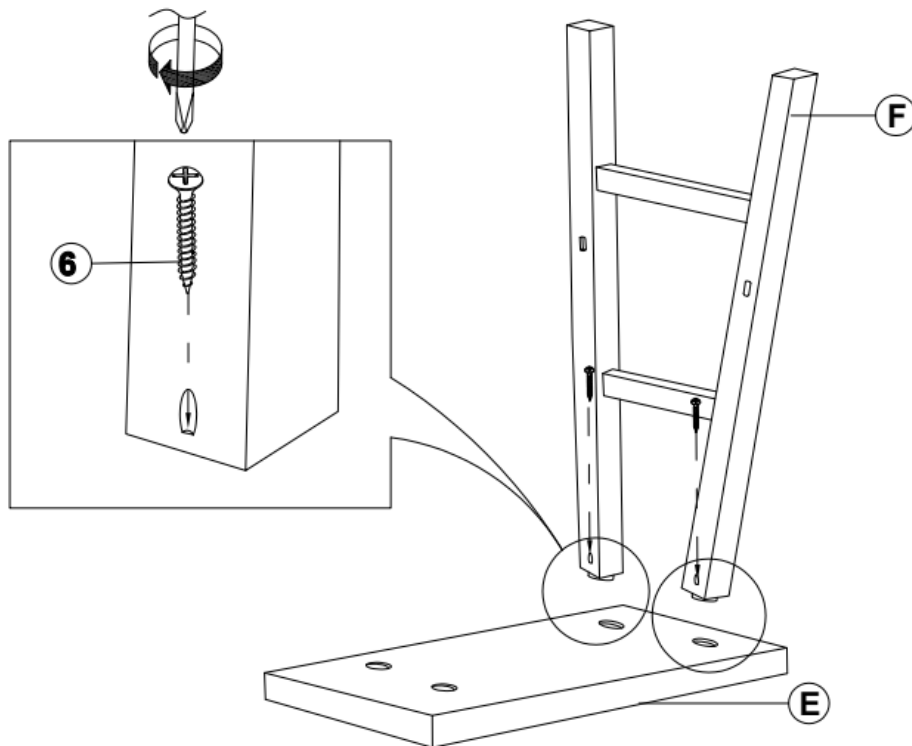

STEP 8

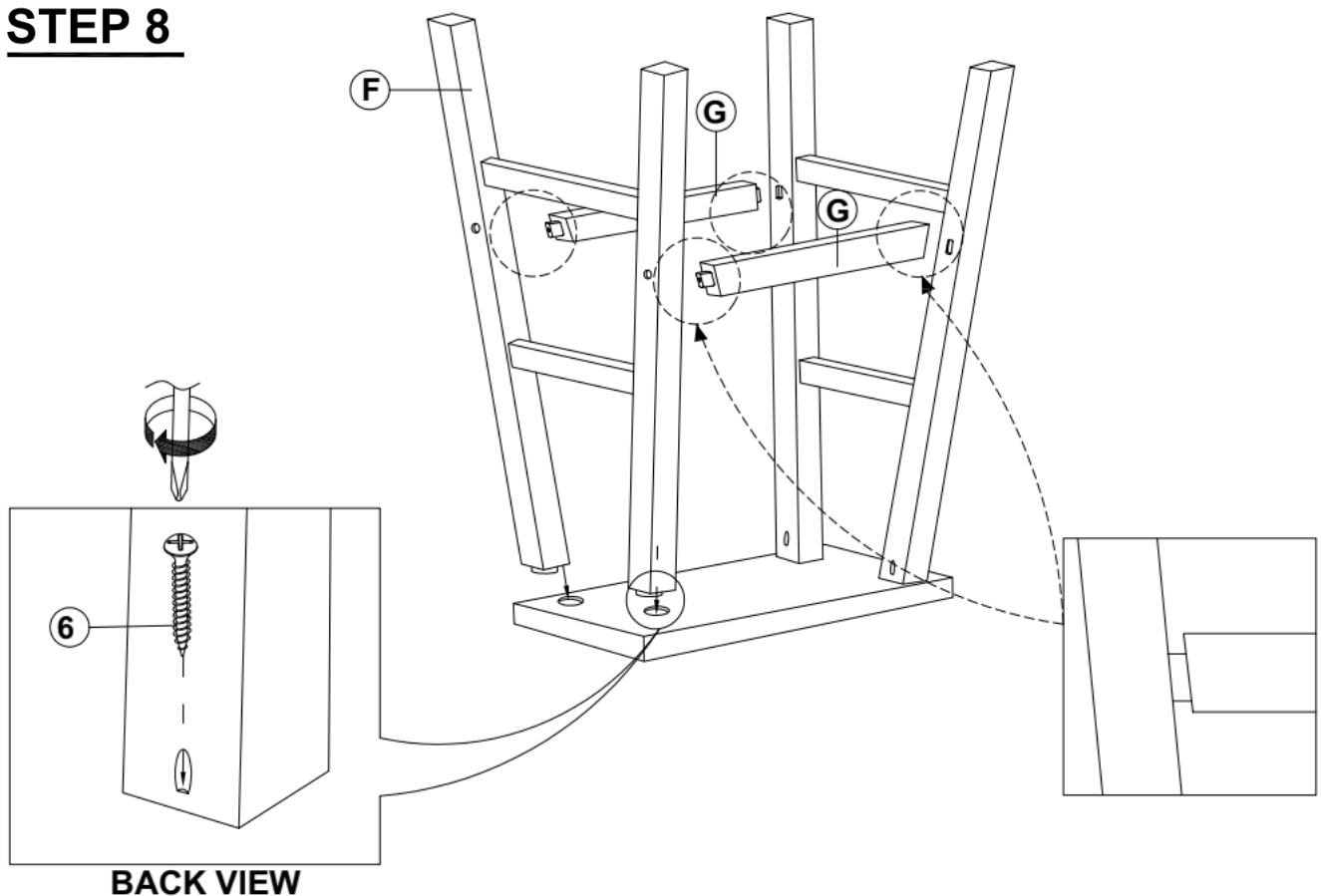

ITEM: **192090**

ASSEMBLY INSTRUCTIONS

STEP 9

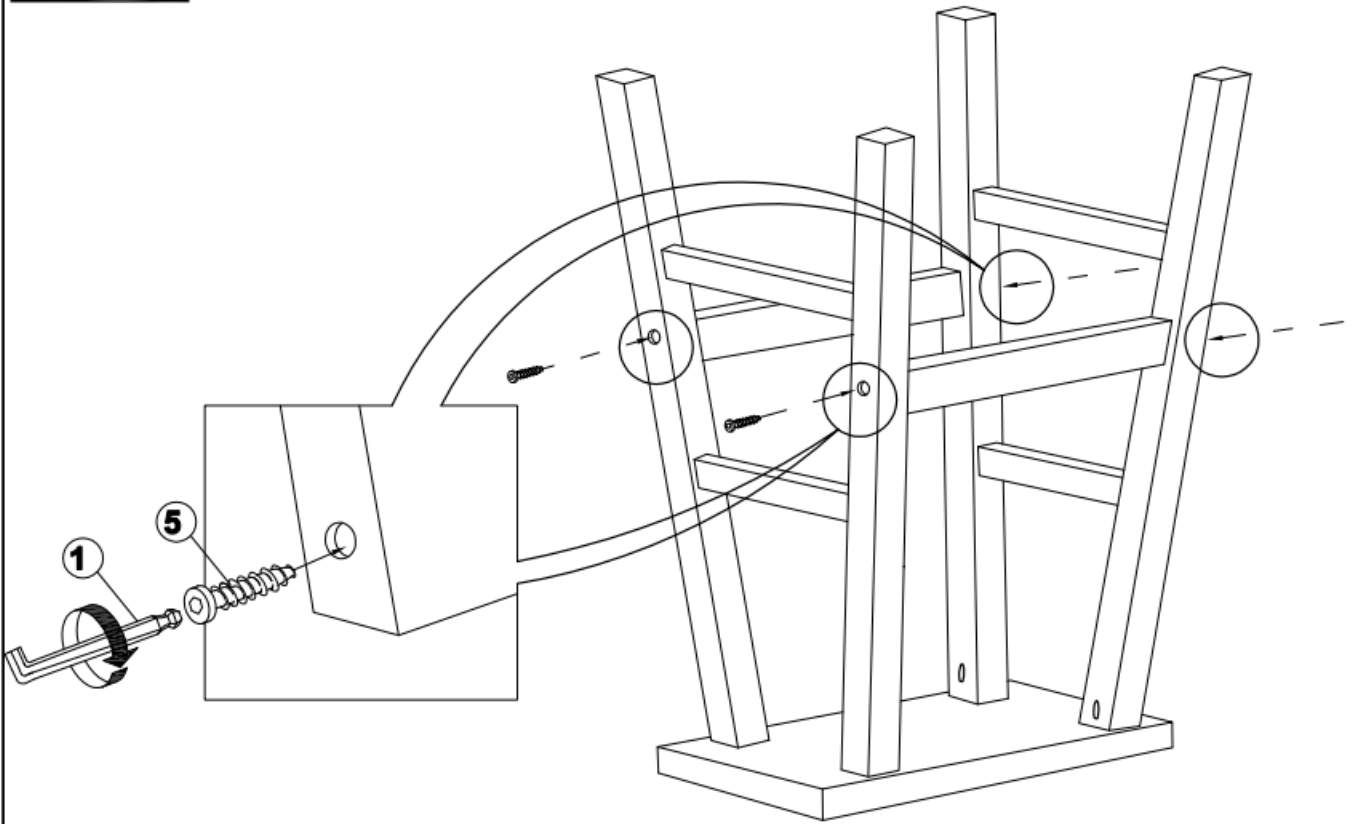

STEP 10

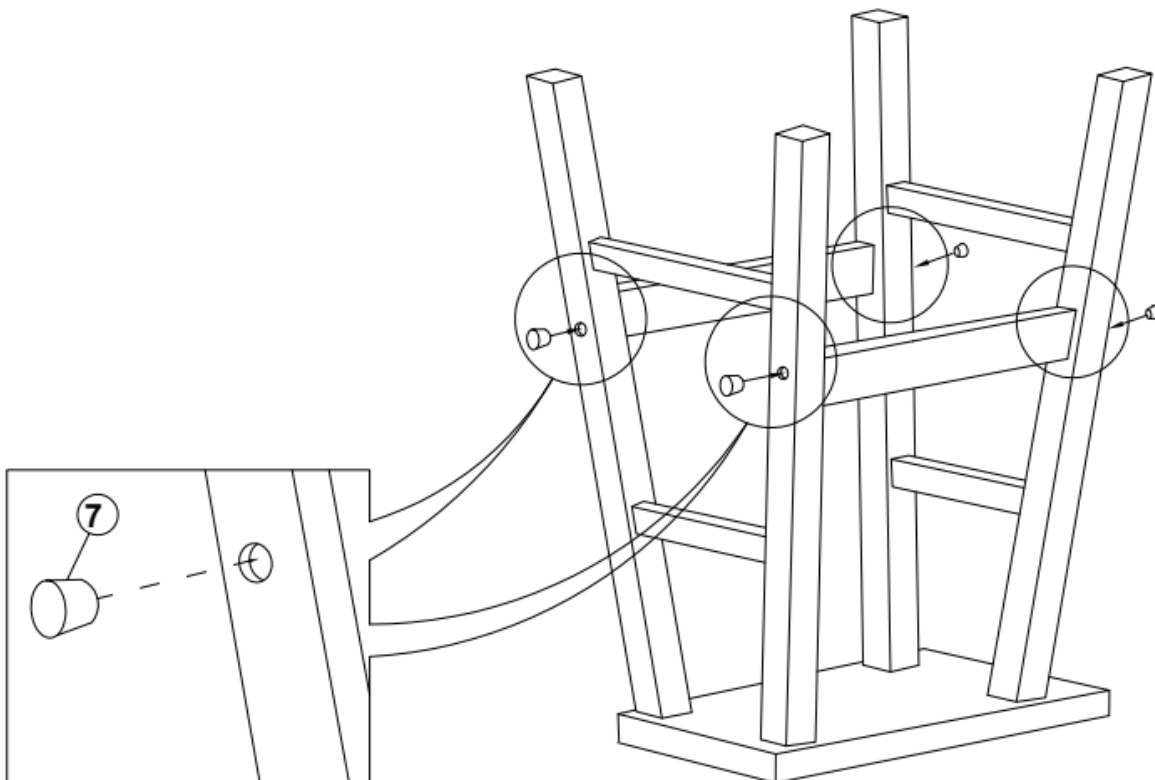

ITEM: **192090**

ASSEMBLY INSTRUCTIONS

STEP 11

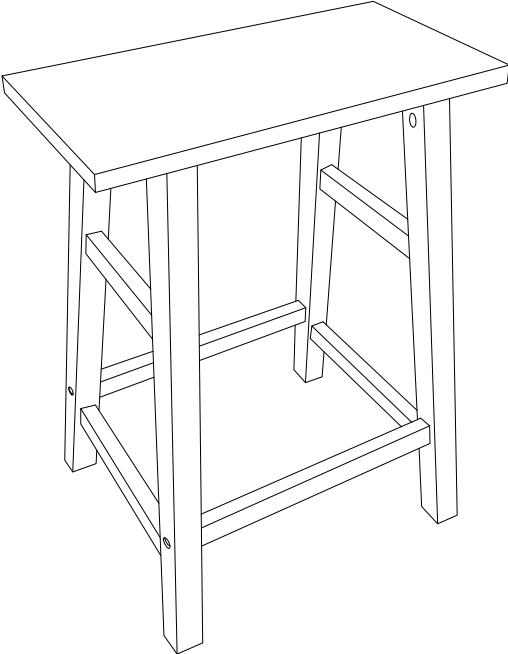

BENCH

STEP 12

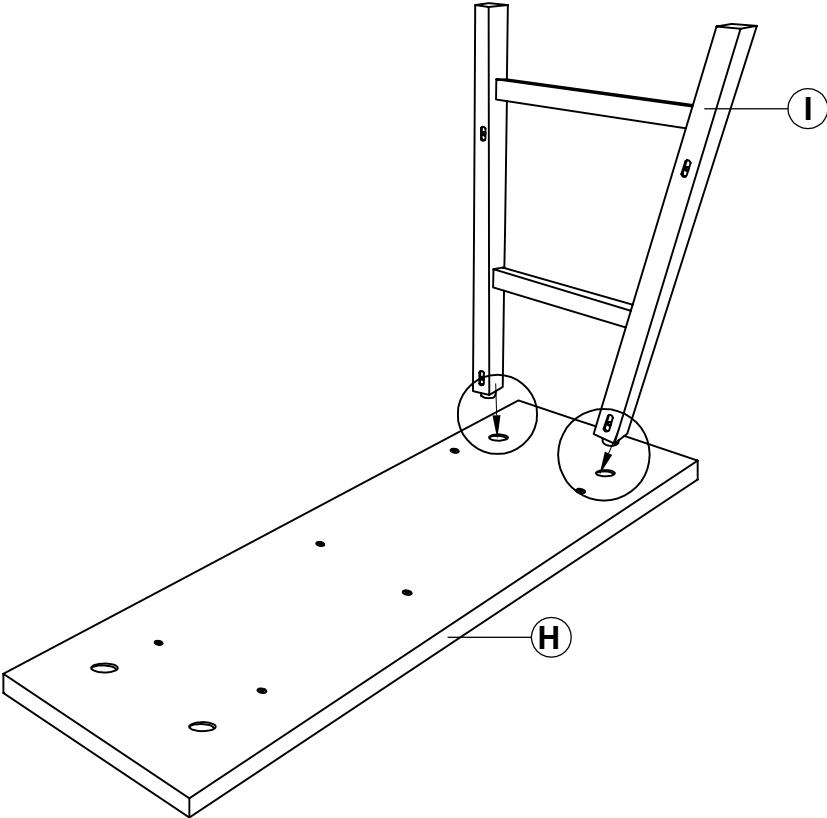

ITEM: **192090**

ASSEMBLY INSTRUCTIONS

STEP 13

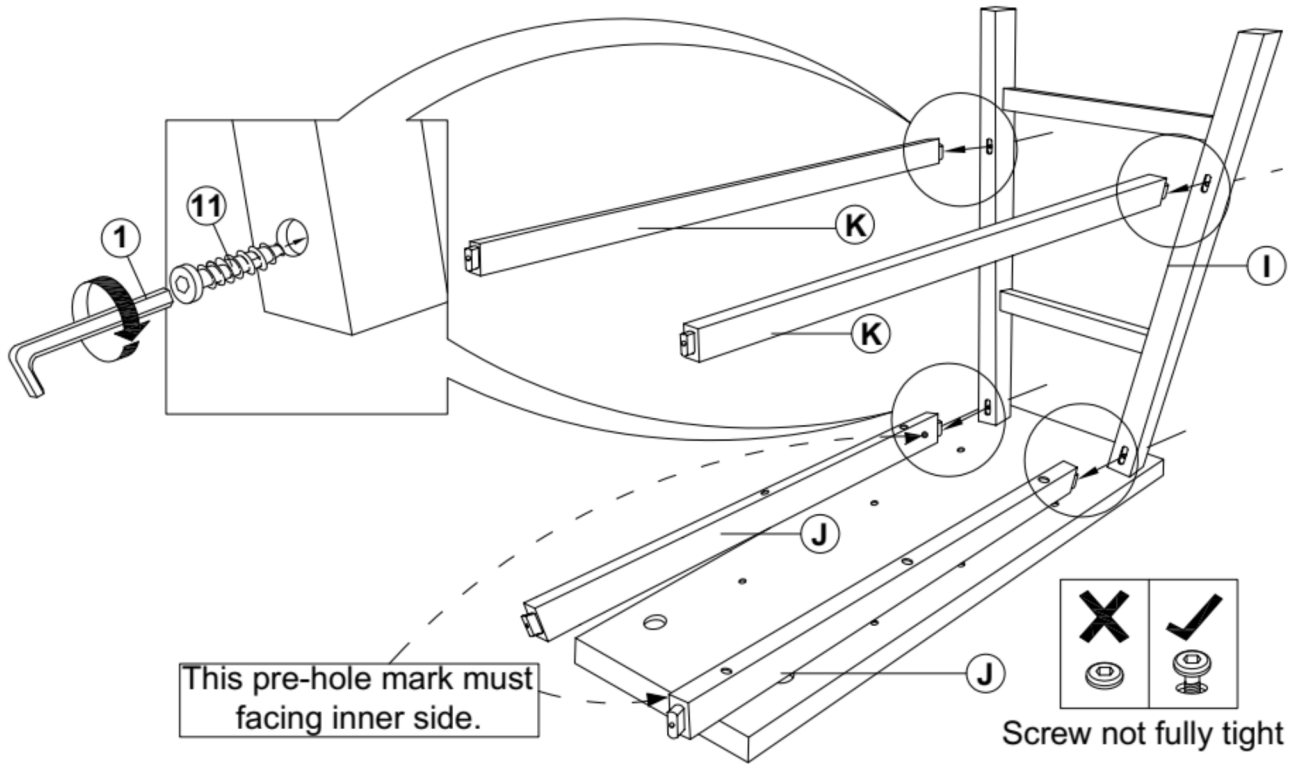

STEP 14

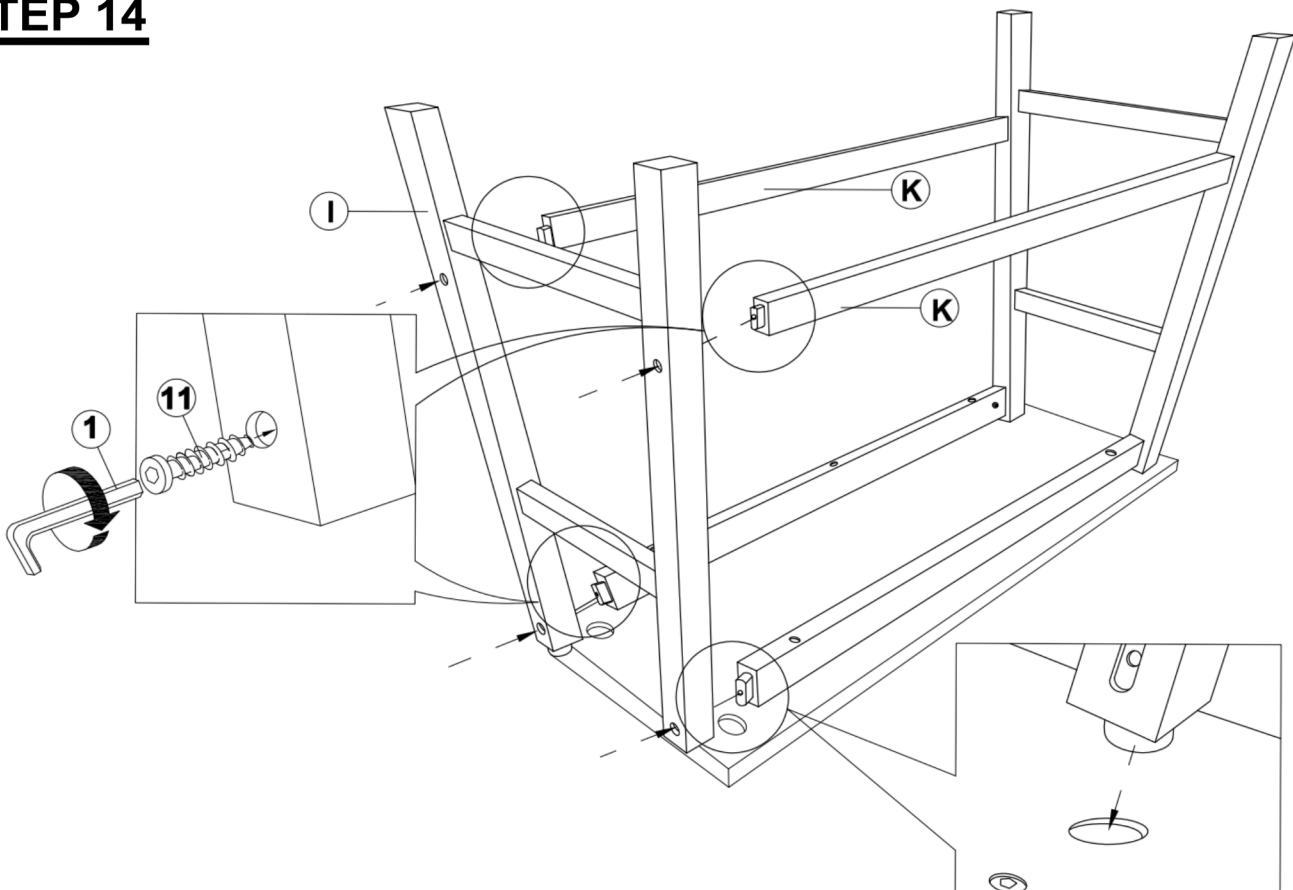

ITEM: **192090**

ASSEMBLY INSTRUCTIONS



STEP 15

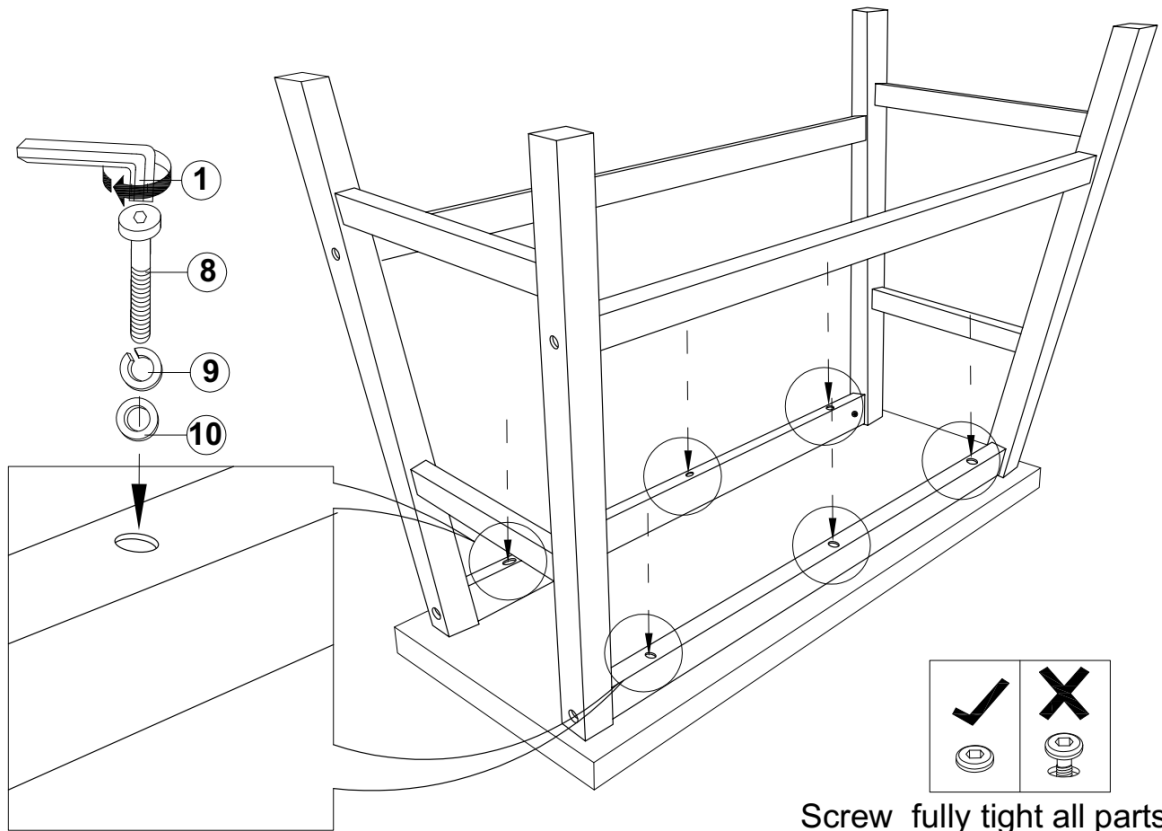

STEP 16

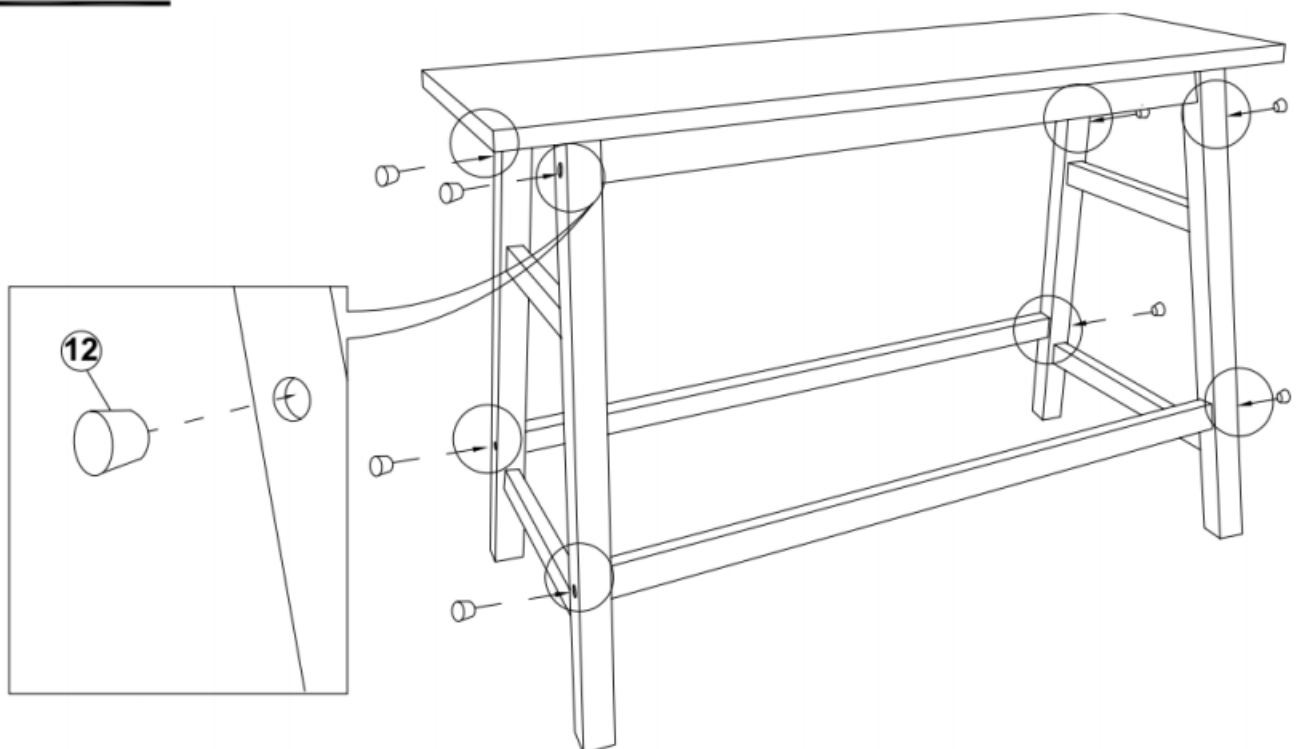

ITEM: **192090**

ASSEMBLY INSTRUCTIONS

STEP 17

COMPLETE

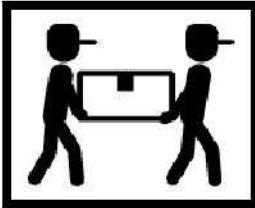

ITEM: **192090**

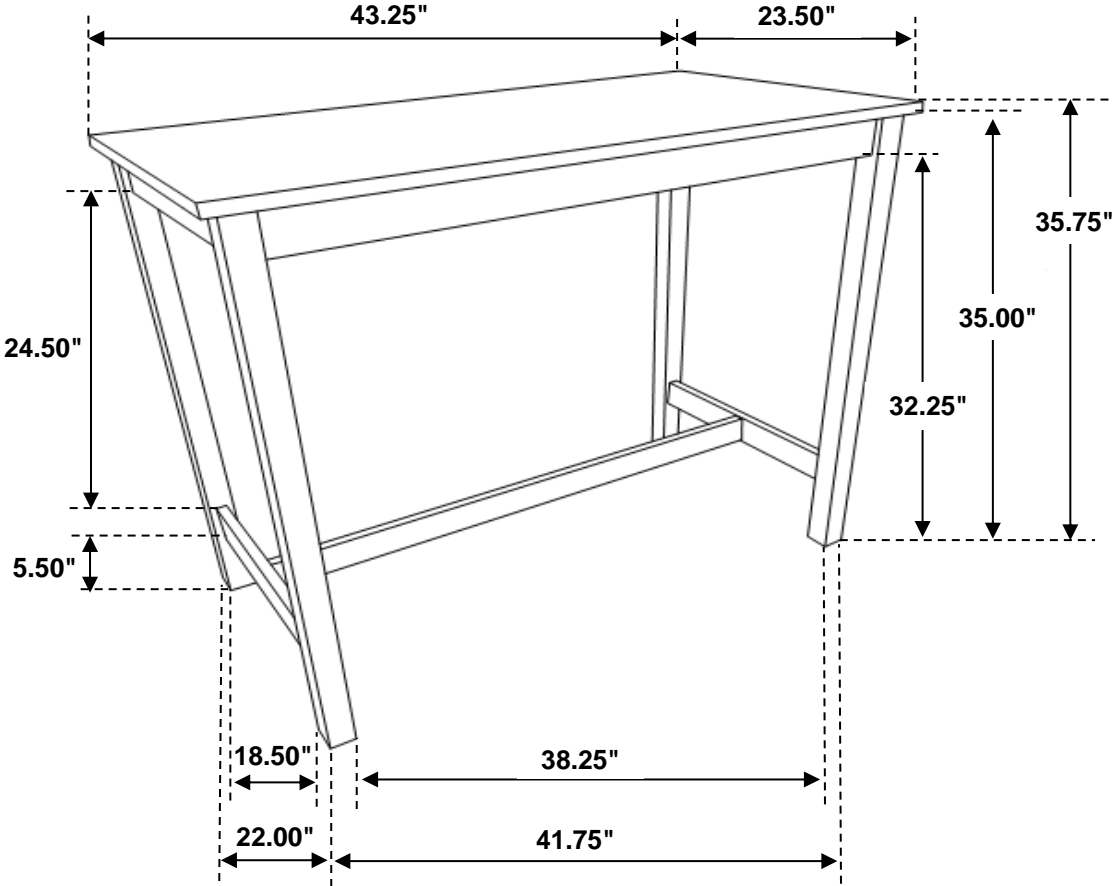

Note : Dimension tolerance $\pm 5\%$

ITEM: 192090

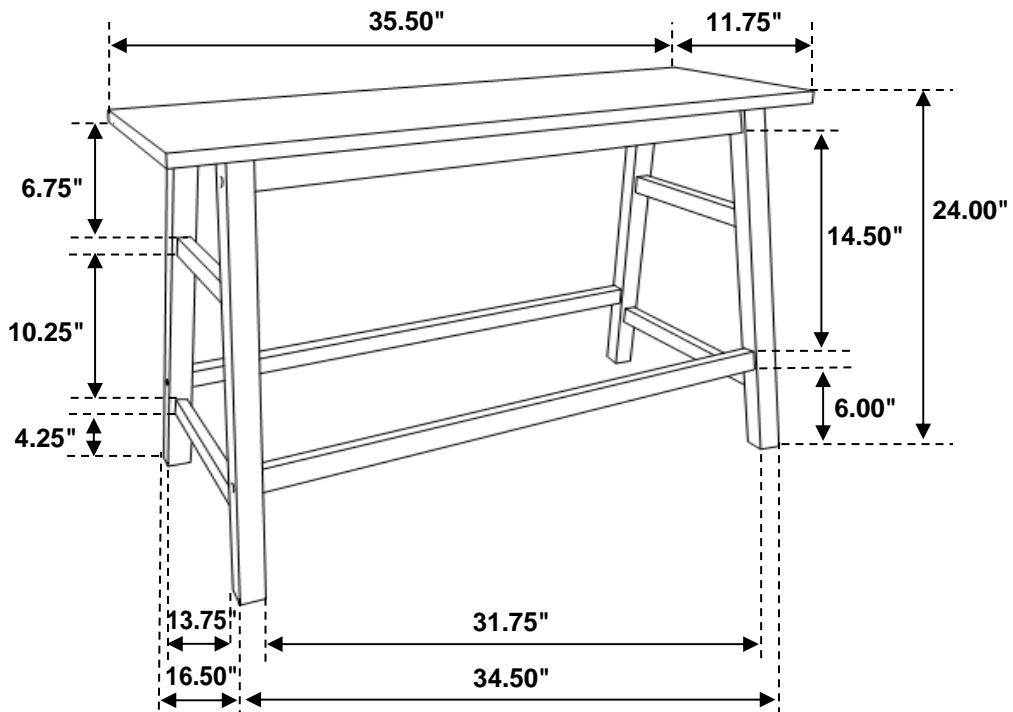
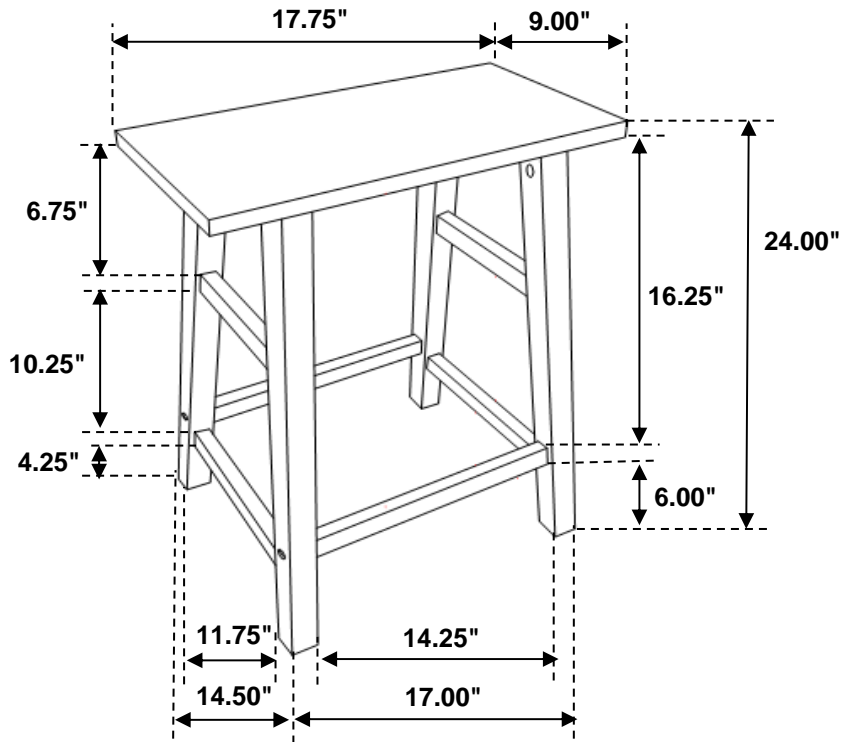

Note : Dimension tolerance $\pm 5\%$