

ASSEMBLY INSTRUCTIONS
COASTER FINE FURNITURE



Fine Furniture for every stage of life

223391KW (B1-B3)
California King Bed

ITEM: 223391KW(B1-B3)



ASSEMBLY INSTRUCTIONS

ASSEMBLY TIPS:

1. Remove hardware from box and sort by size.
2. Please check to see that all hardware and parts are present prior to start of assembly.
3. Please follow attached instructions in the same sequence as numbered to assure fast & easy assembly.



WARNING!

1. Don't attempt to repair or modify parts that are broken or defective. Please contact the store immediately.
2. This product is for home use only and not intended for commercial establishments.



ASSEMBLY TIME



30 MINUTES

PARTS IDENTIFICATION

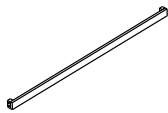
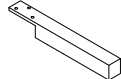
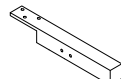

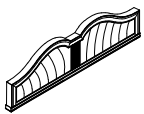

B1 (BOX 1)

A	HEADBOARD PANEL		1PC		B	HEADBOARD BOTTOM RAIL		1PC
C	RIGHT HEADBOARD LEG		1PC		D	LEFT HEADBOARD LEG		1PC

B2 (BOX 2)

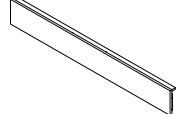
E	FOOTBOARD		1PC		F	RIGHT FOOTBOARD LEG		1PC
G	LEFT FOOTBOARD LEG		1PC					

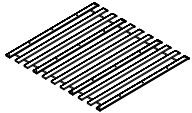
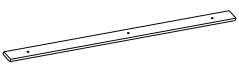
B3 (BOX 3)

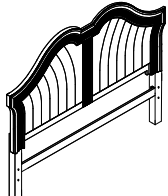
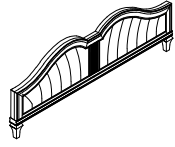
H	BED RAIL		2PCS		I	BED SLAT SUPPORT WITH LEVELER		8PCS
J	ROLL SLAT (11PCS)		1SET		K	CENTER RAIL		1PC
L	CENTER RAIL SUPPORT WITH LEVELER		3PCS					
HB	223391KW (B1) FROM BOX 1 HEADBOARD COMPLETE		1PC		FB	223391KW (B2) FROM BOX 2 FOOTBOARD		1PC

NOTE:

Phillips head screw driver is required in the assembly process; however, manufacturer does not provide this item.

ITEM: 223391KW(B1-B3)



ASSEMBLY INSTRUCTIONS

ASSEMBLY TIPS:

1. Remove hardware from box and sort by size.
2. Please check to see that all hardware and parts are present prior to start of assembly.
3. Please follow attached instructions in the same sequence as numbered to assure fast & easy assembly.





WARNING!







1. Don't attempt to repair or modify parts that are broken or defective. Please contact the store immediately.
2. This product is for home use only and not intended for commercial establishments.

HARDWARE IDENTIFICATION





Z-B1 (BOX 1) - HARDWARE PACK IS LOCATED IN 223391KW (B1)

1	BOLT (\varnothing 5/16" x 45MM - RBW)		10PCS	2	LOCK WASHER (\varnothing 5/16" - RBW)		10PCS
3	FLAT WASHER (\varnothing 5/16" - RBW)		10PCS	4	ALLEN WRENCH (4MM - RBW)		1PC

Z-B2 (BOX 2) - HARDWARE PACK IS LOCATED IN 223391KW (B2)

5	BOLT (\varnothing 5/16" x 55MM - RBW)		4PCS	6	LOCK WASHER (\varnothing 5/16" - RBW)		4PCS
7	FLAT WASHER (\varnothing 5/16" - RBW)		4PCS	8	ALLEN WRENCH (4MM - RBW)		1PC

Z-B3 (BOX 3) - HARDWARE PACK IS LOCATED IN 223391KW (B3)

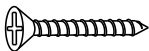
9	THREADED BOLT (\varnothing 5/16" x 90MM - RBW)		8PCS	10	HALF ROUND NUT (\varnothing 5/16" - RBW)		8PCS
11	HEX NUT (\varnothing 5/16" x 14MM - RBW)		8PCS	12	WRENCH (14MM - RBW)		1PC
13	FLAT HEAD SCREW (\varnothing 4 x 30MM - RBW)		12PCS				

NOTE:

Phillips head screw driver is required in the assembly process; however, manufacturer does not provide this item.

ITEM: 223391KW(B1-B3)

ASSEMBLY INSTRUCTIONS



STEP 1

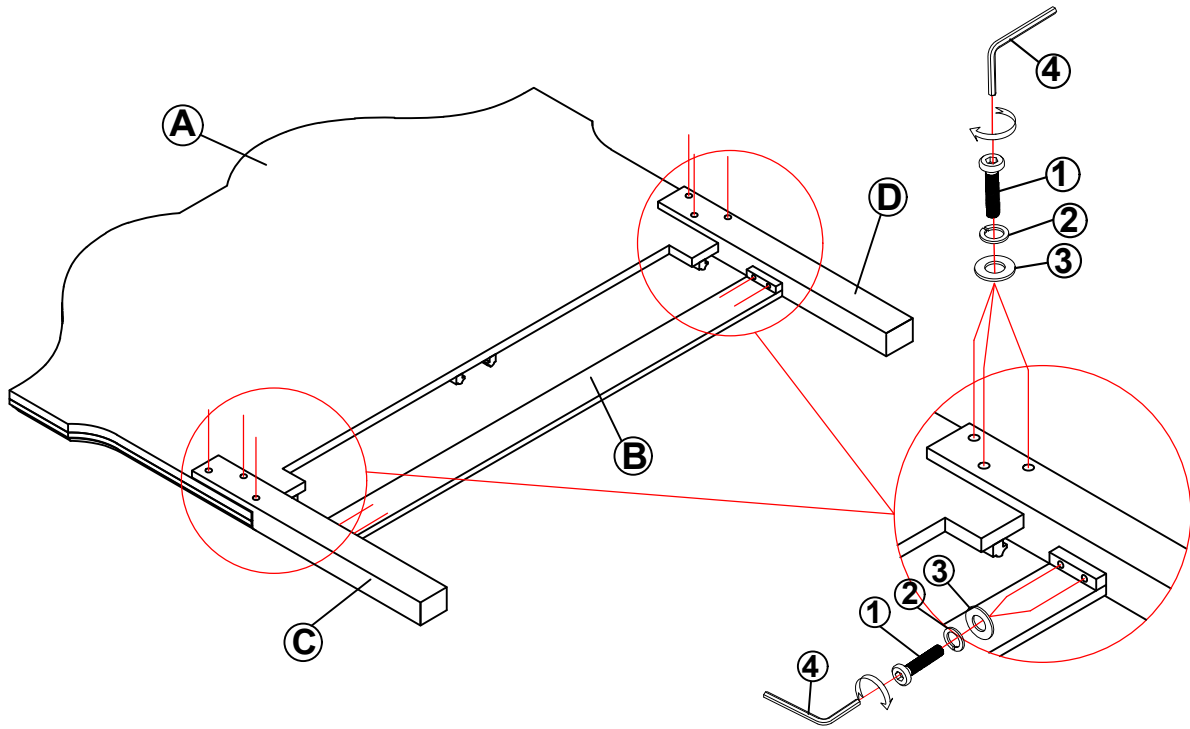

STEP 2

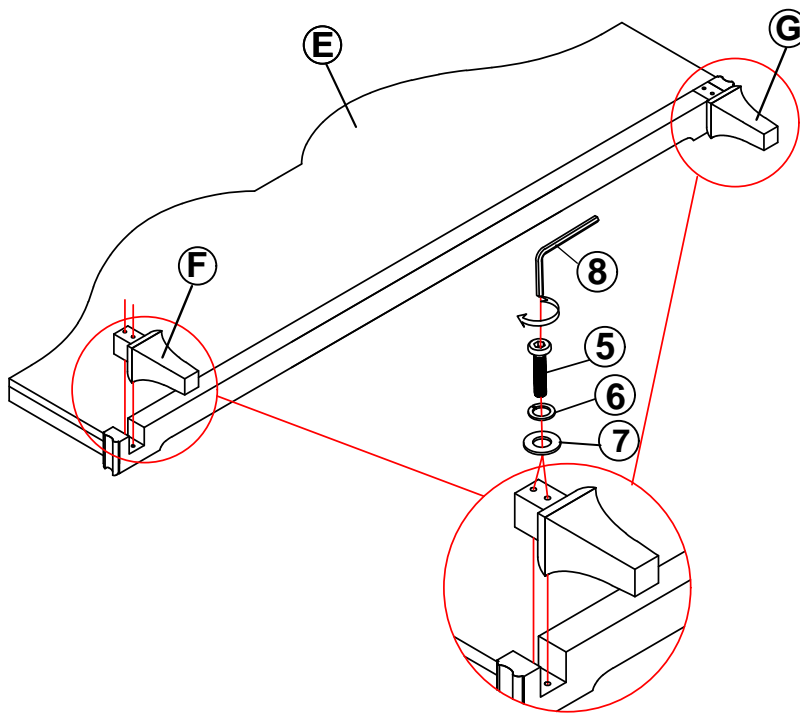

ITEM: 223391KW(B1-B3)

ASSEMBLY INSTRUCTIONS

STEP 3

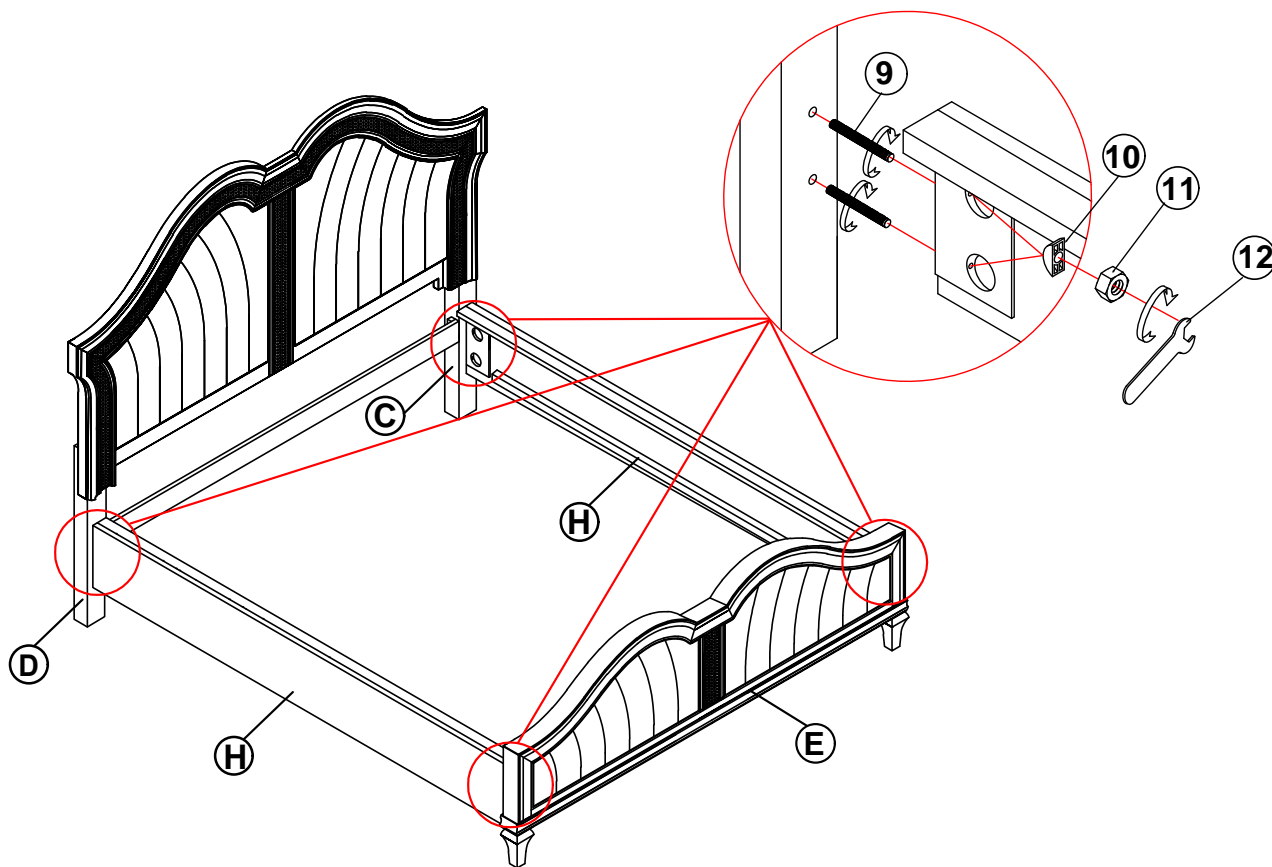

STEP 4

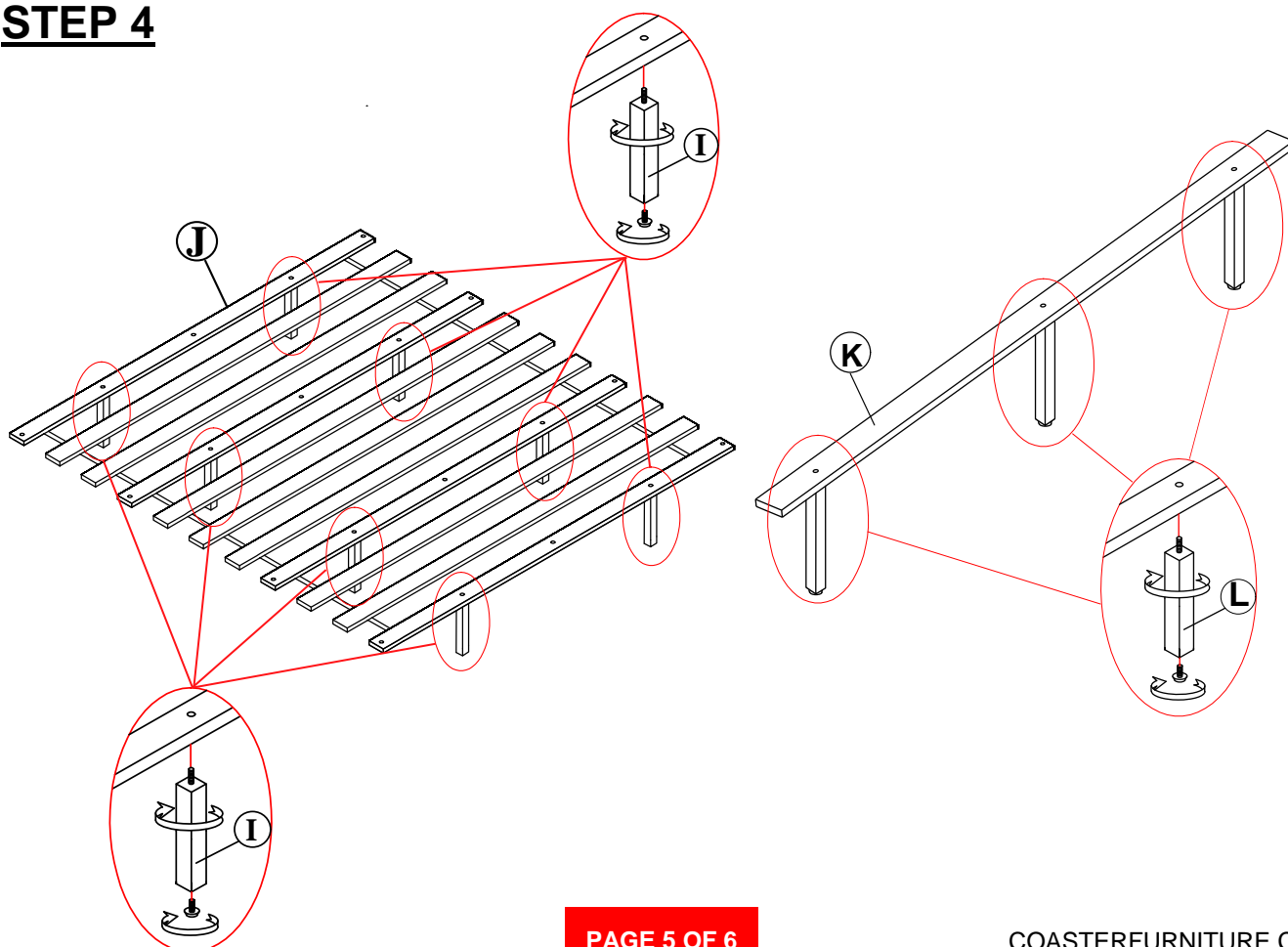

ITEM: **223391KW(B1-B3)**

ASSEMBLY INSTRUCTIONS

STEP 5

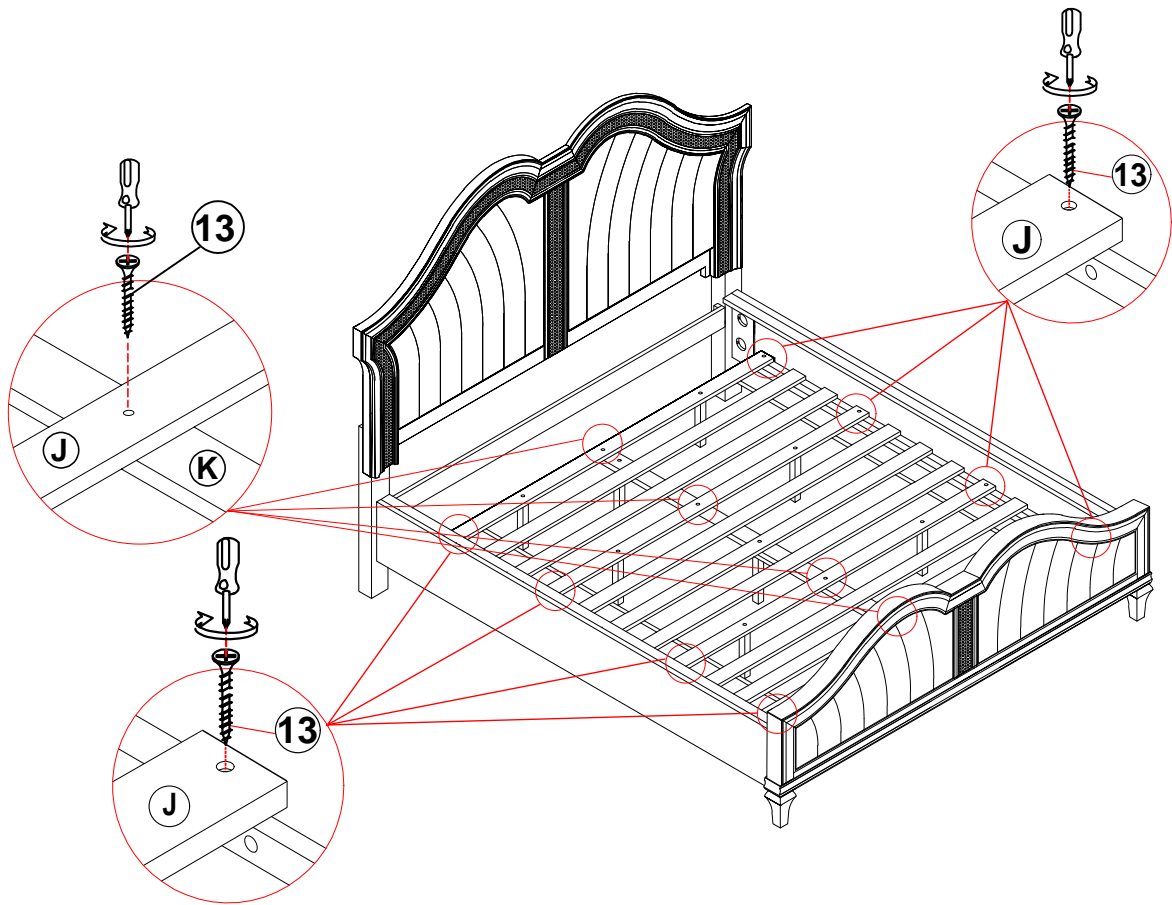

STEP 6
COMPLETE

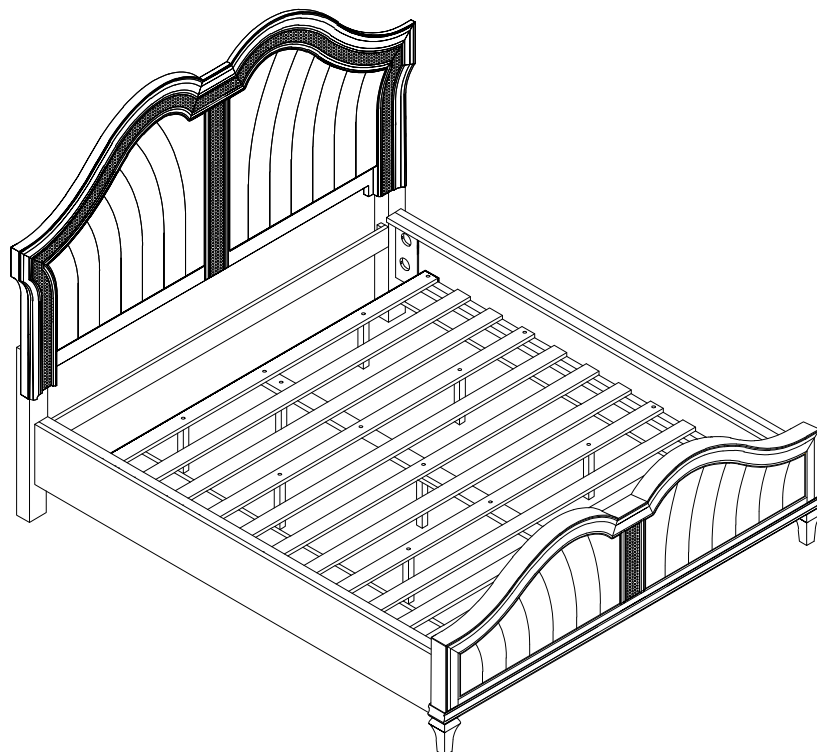

ITEM: 223391KW(B1-B3)



Inner Size : 85.50"W X 77.00"D

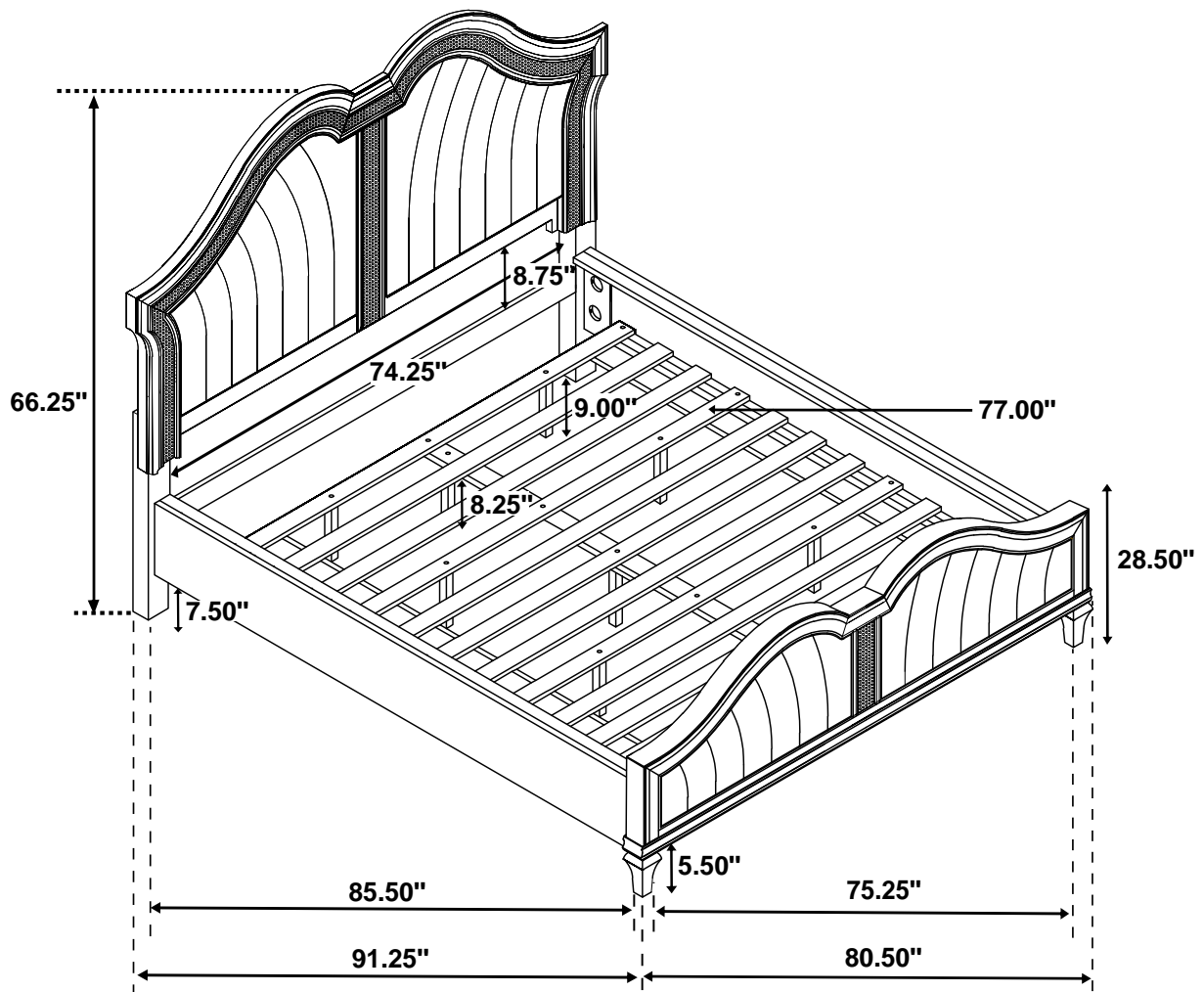

Note: Dimension tolerance $\pm 5\%$