

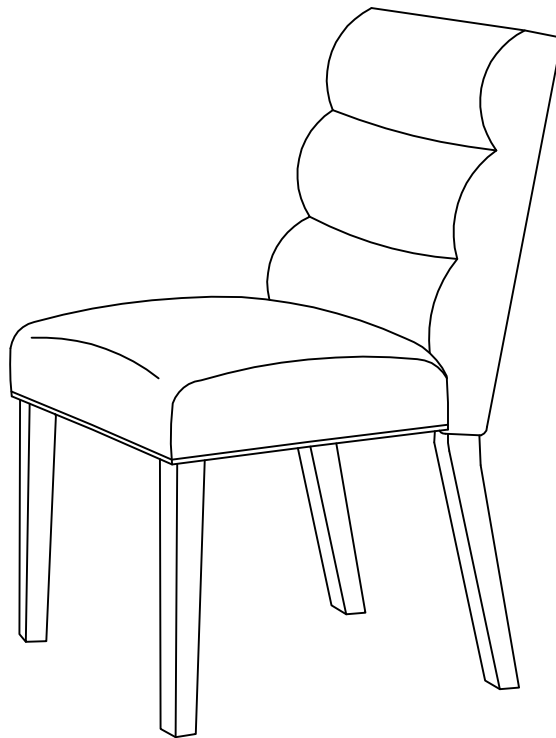

ASSEMBLY INSTRUCTIONS COASTER FINE FURNITURE



Fine Furniture for every stage of life

106683
Side Chair

ITEM: 106683



ASSEMBLY INSTRUCTIONS

ASSEMBLY TIPS:

1. Remove hardware from box and sort by size.
2. Please check to see that all hardware and parts are present prior to start of assembly.
3. Please follow attached instructions in the same sequence as numbered to assure fast & easy assembly.





WARNING!

1. Don't attempt to repair or modify parts that are broken or defective. Please contact the store immediately.
2. This product is for home use only and not intended for commercial establishments.

ASSEMBLY TIME



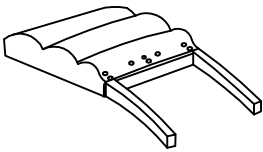

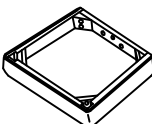
30 MINUTES

PARTS IDENTIFICATION

A	BACK		1PC	C	LEG		2PCS
B	SEAT		1PC				

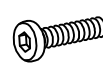
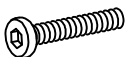
HARDWARE IDENTIFICATION

Z

1	ALLEN WRENCH (5MM - BLK)		1PC	4	ALLEN BOLT (Ø5/16 x 2" - BLK)		3PCS
2	ALLEN BOLT (Ø5/16 x 3-1/2" - BLK)		4PCS	5	LOCK WASHER (Ø5/16" -BLK)		11PCS
3	ALLEN BOLT (Ø5/16 x 2-1/4" - BLK)		4PCS	6	FLAT WASHER (Ø5/16" x 19MM - BLK)		11PCS

NOTE:

Quantities shown are for one chair.

ITEM:106683



ASSEMBLY INSTRUCTIONS

STEP 1

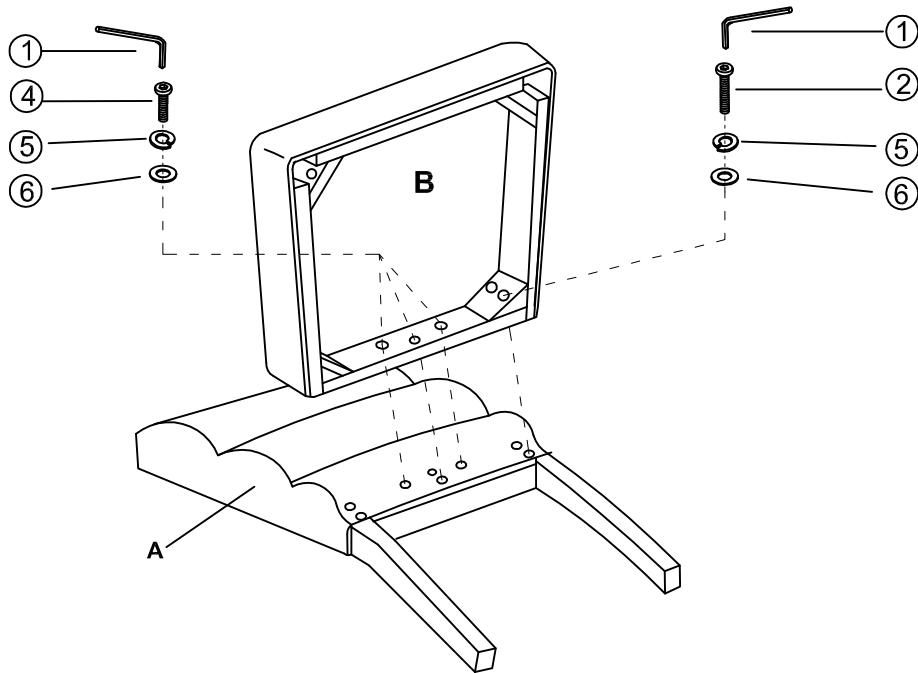

STEP 2

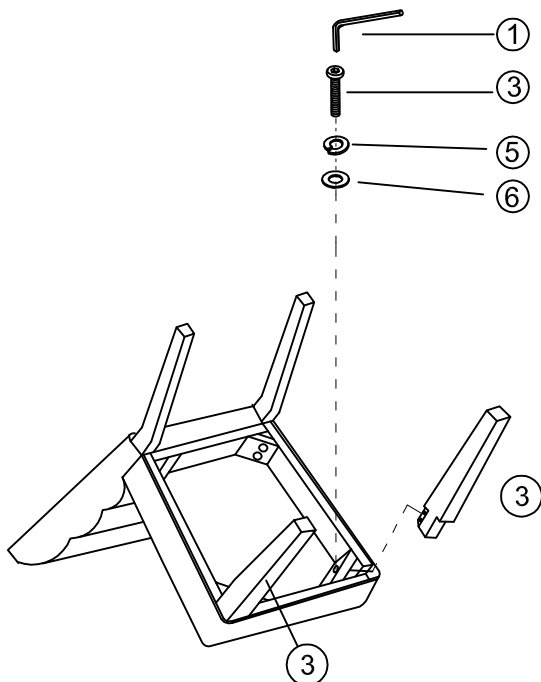

STEP 3
COMPLETE

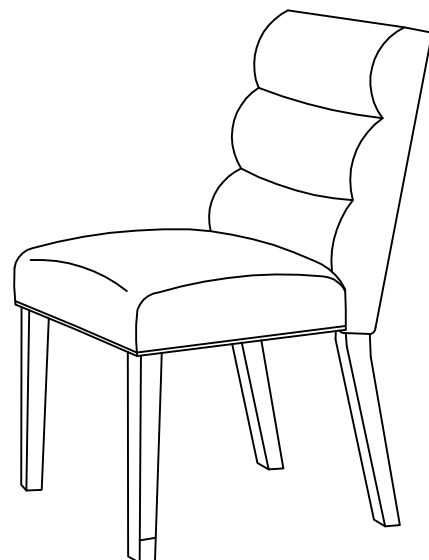

ITEM:106683

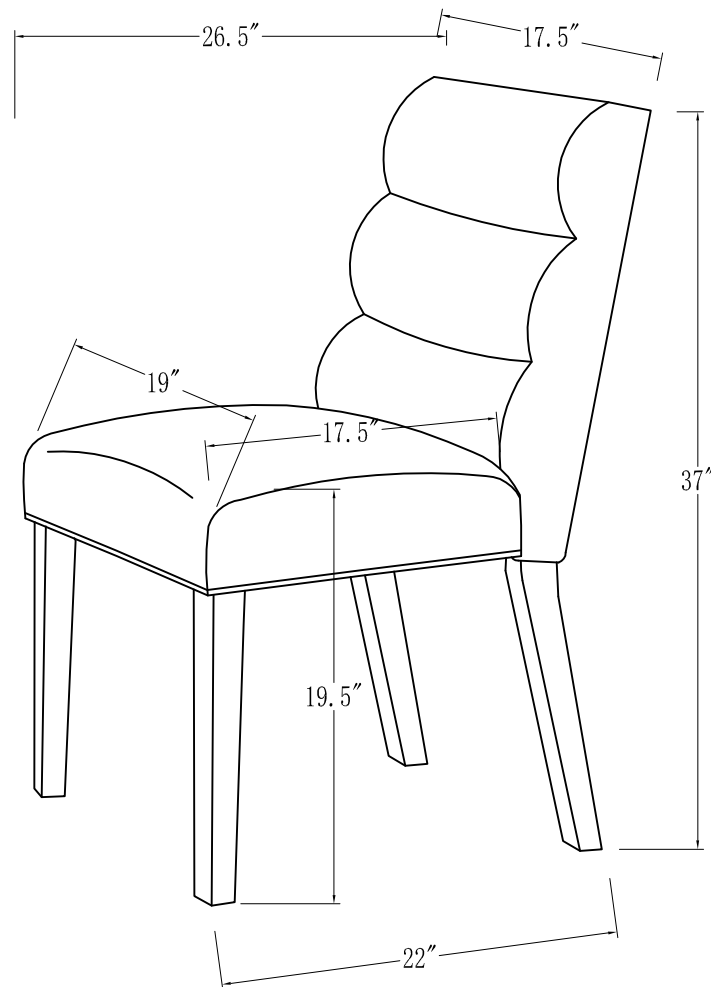

Note : Dimension tolerance $\pm 5\%$