



ASSEMBLY INSTRUCTIONS
COASTER FINE FURNITURE



Fine Furniture for every stage of life

121168
Counter Height Dining Table

ITEM: 121168



ASSEMBLY INSTRUCTIONS

ASSEMBLY TIPS:

1. Remove hardware from box and sort by size.
2. Please check to see that all hardware and parts are present prior to start of assembly.
3. Please follow attached instructions in the same sequence as numbered to assure fast & easy assembly.



WARNING!









1. Don't attempt to repair or modify parts that are broken or defective. Please contact the store immediately.
2. This product is for home use only and not intended for commercial establishments.

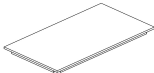

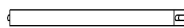



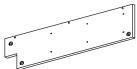

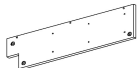
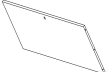





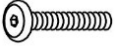

ASSEMBLY TIME

15 MINUTES

PARTS IDENTIFICATION

A	TOP		1PC	G	CROSSBAR		1PC
B	LEFT FRONT LEG		1PC	H	SIDE STRETCHER		1PC
C	RIGHT FRONT LEG		1PC	I	SHELF		3PCS
D	LEFT BACK LEG		1PC	K	LEFT SIDE PANEL		1PC
E	RIGHT BACK LEG		1PC	L	RIGHT SIDE PANEL		1PC
F	BACK PANEL		1PC				

HARDWARE IDENTIFICATION

1	LONG BOLT (Ø5/16" x 2-1/2" - BLK)		8PCS	9	BIG WOOD DOWEL (10*30mm - BLK)		4PCS
2	LOCK WASHER (Ø5/16" - BLK)		8PCS	10	SHELF SUPPORT		12PCS
3	FLAT WASHER (Ø5/16" - BLK)		8PCS	11	FLAT HEAD SCREW (Ø8 - 5/8" BLK)		33PCS
4	SHORT BOLT (Ø1/4" x 1-1/2" - BLK)		6PCS	12	PAN HEAD SCREW (Ø8 - 1-3/4" BLK)		2PCS
5	LOCK WASHER (Ø1/4" - BLK)		6PCS	13	METAL BRACKET		6PCS
6	FLAT WASHER (Ø1/4" - BLK)		6PCS	14	L BRACKET		1PC
7	T BRACKET		1PC	15	ALLEN WRENCH Ø4*58mm		1PC
8	SMALL WOOD DOWEL (8*30mm - BLK)		6PCS				

NOTE:

Phillips head screw driver is required in the assembly process ; however, manufacturer does not provide this item.

ITEM: **121168**

ASSEMBLY INSTRUCTIONS



STEP 1

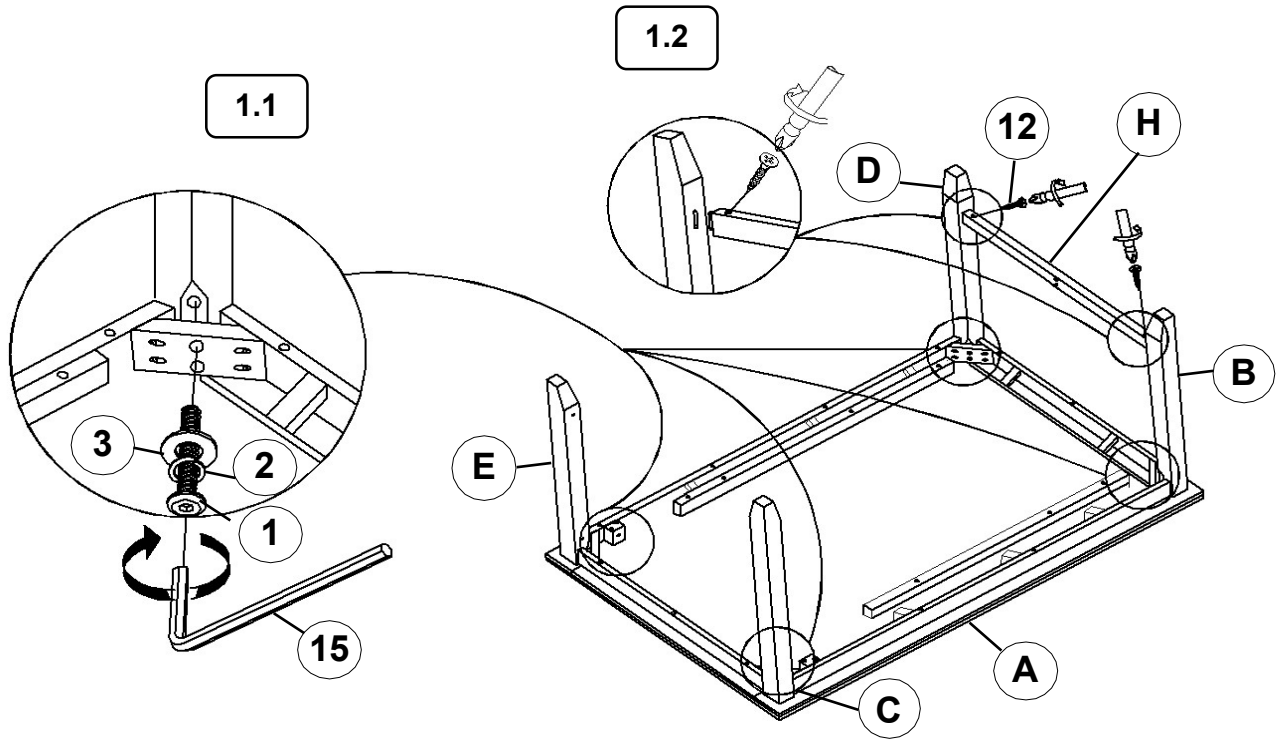

STEP 2

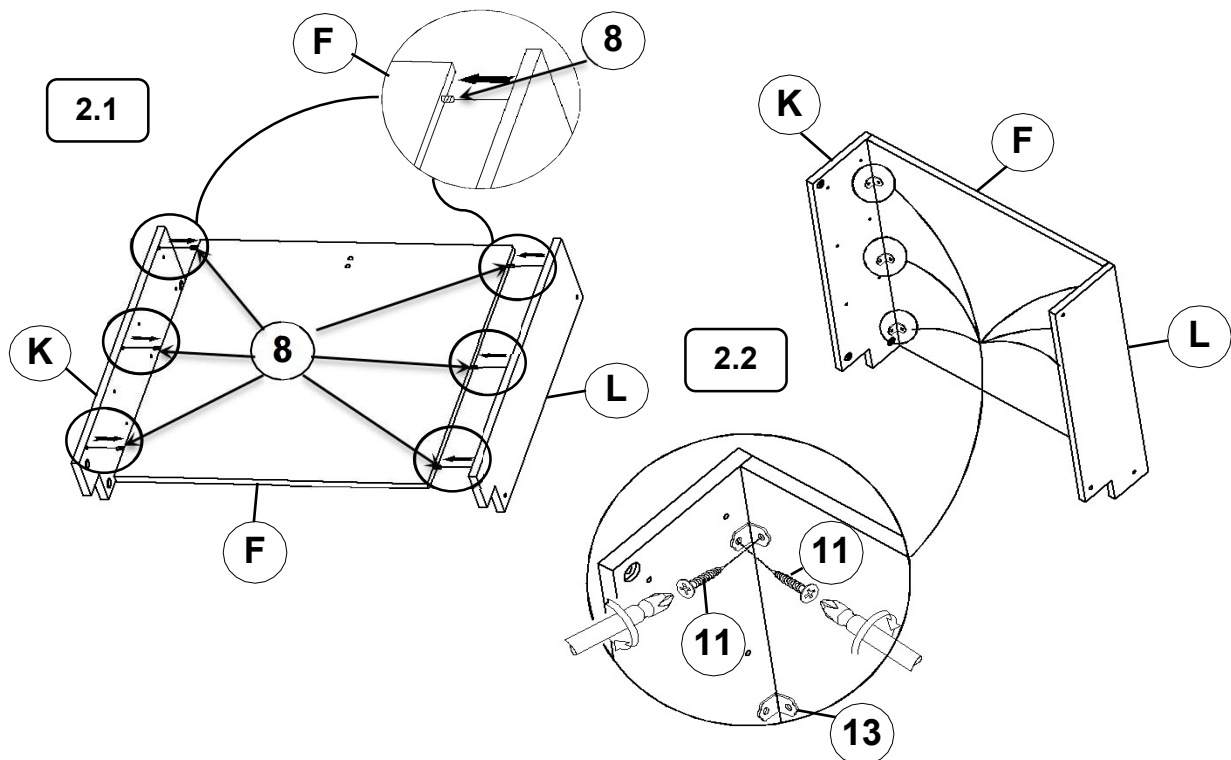

ITEM: **121168**

ASSEMBLY INSTRUCTIONS

STEP 3

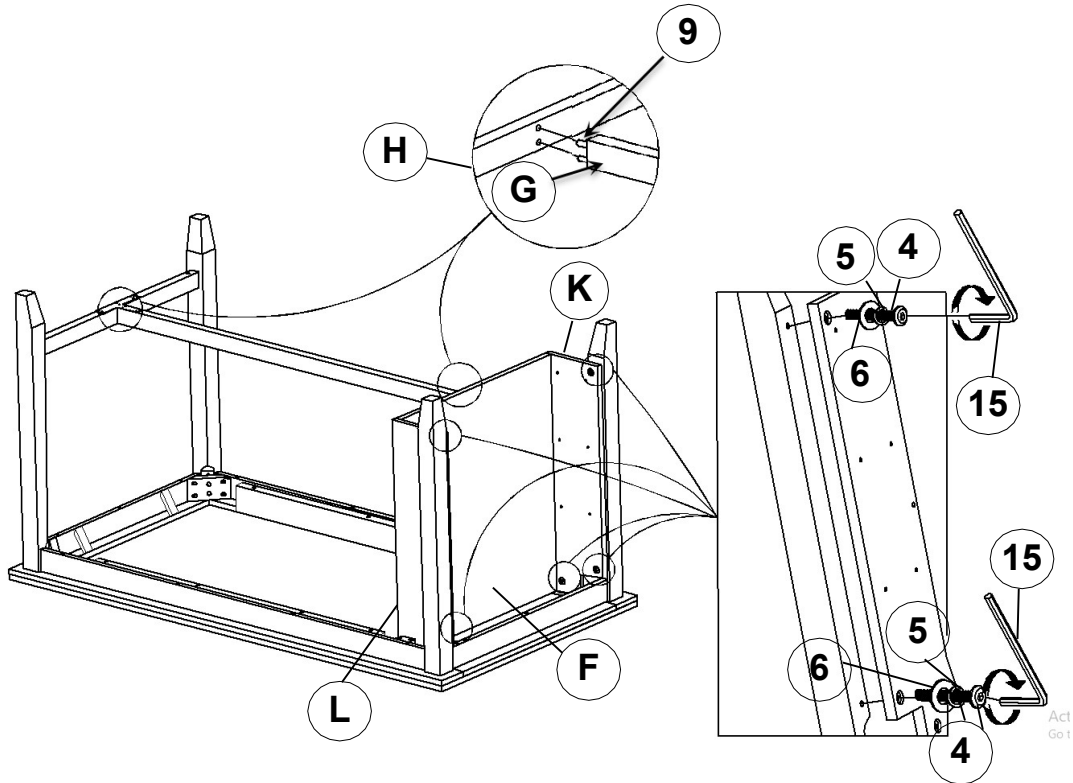

STEP 4

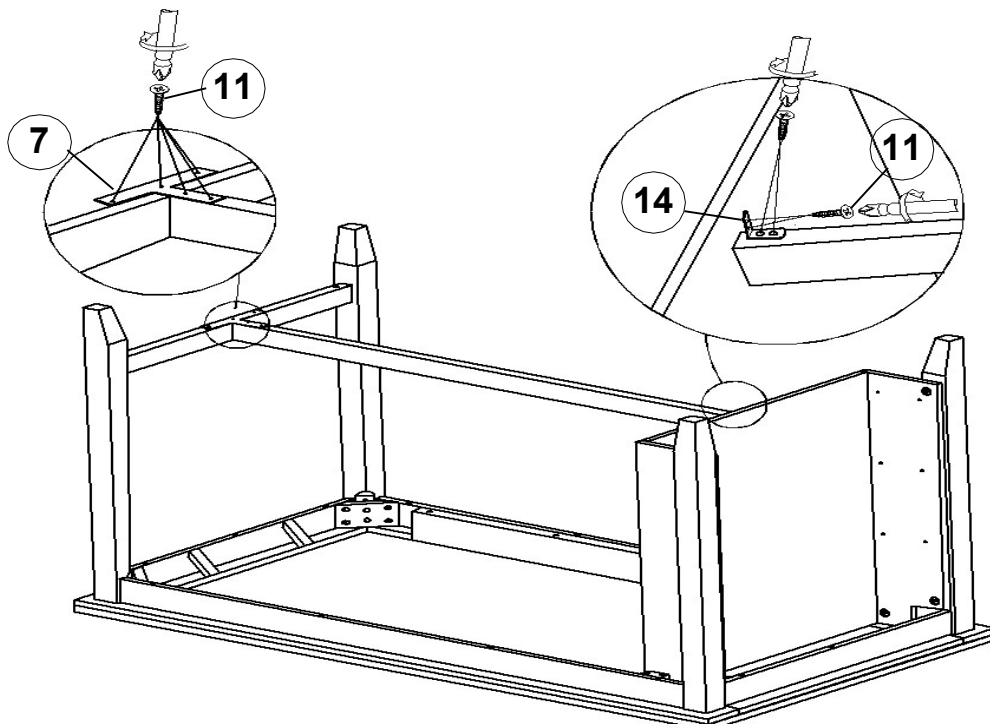

ITEM: **121168**



ASSEMBLY INSTRUCTIONS

STEP 5

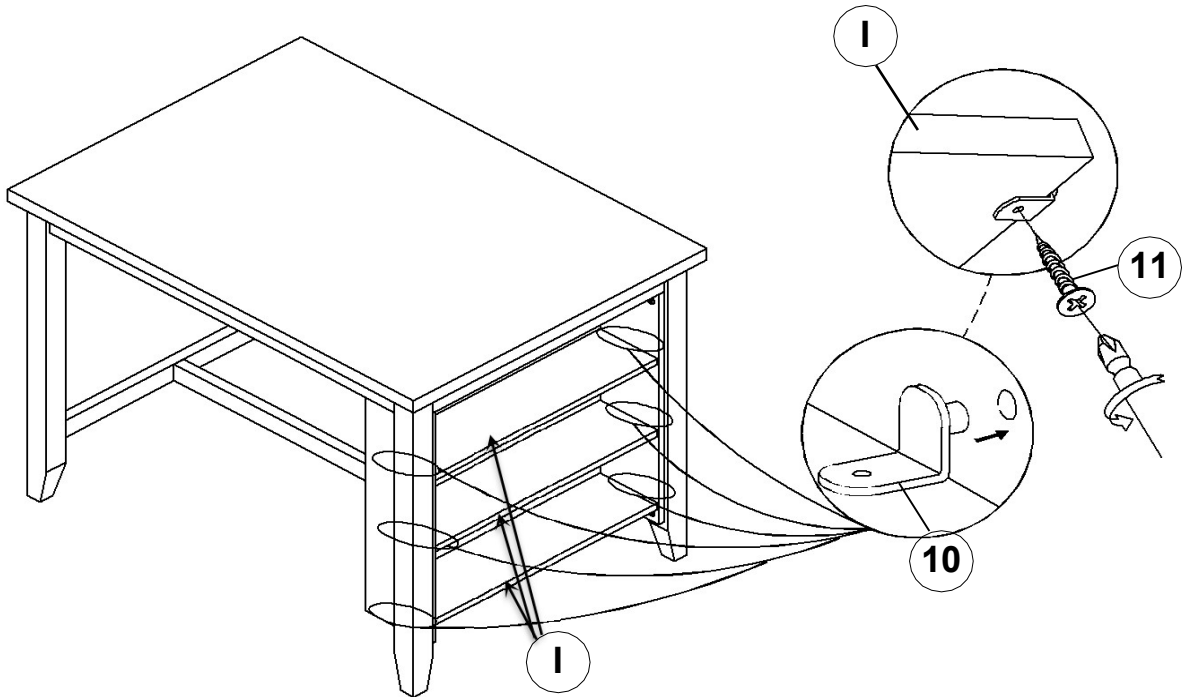

STEP 6 COMPLETE

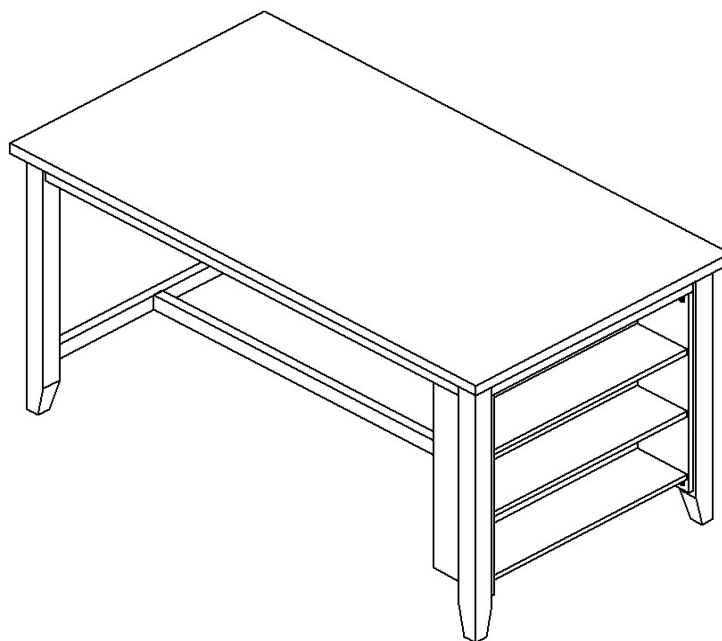

ITEM: **121168**

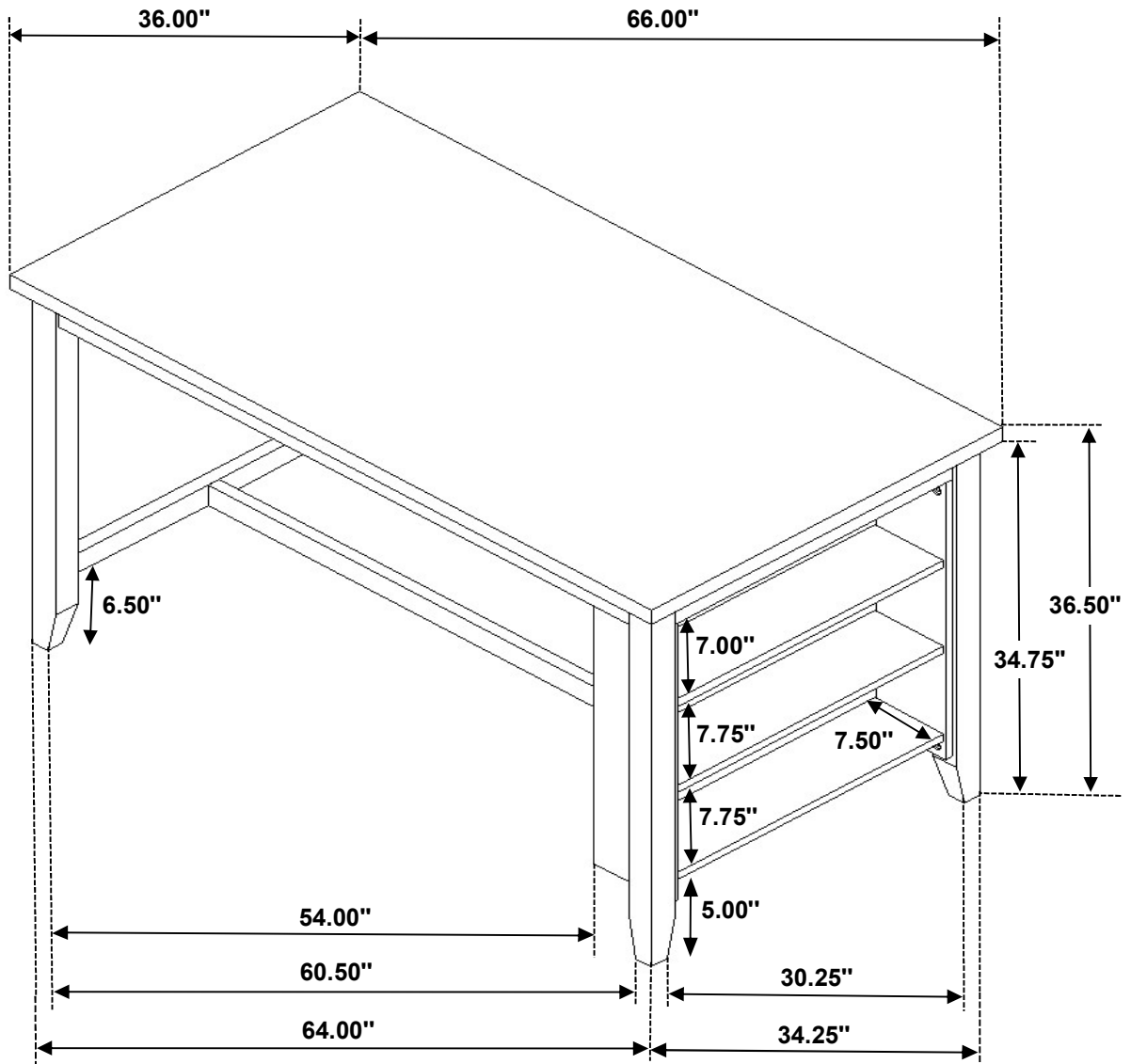

Note :Dimension tolerance $\pm 5\%$