



*ASSEMBLY INSTRUCTIONS  
COASTER FINE FURNITURE*



Fine Furniture for every stage of life

**100424**  
***LEISURE CHAIR***

REVISION 0 : 11/01/2018  
REVISION 1 : 05/13/2019  
REVISION 2 : 09/15/2020  
REVISION 3 : 08/01/2022  
REVISION 4 : 16/11/2023

PAGE 1 OF 3

COASTERFURNITURE.COM

# ITEM : 100424

## ASSEMBLY INSTRUCTIONS



### ASSEMBLY TIPS:

1. Remove hardware from box and sort by size.
2. Please check to see that all hardware and parts are present prior to start of assembly.
3. Please follow attached instructions in the same sequence as numbered to assure fast & easy assembly.



#### Warning!

1. Don't attempt to repair or modify parts that are broken or defective. Please contact the store immediately.
2. This product is for home use only and not intended for commercial establishments.

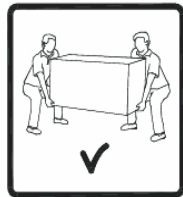

ASSEMBLY TIME	5 MINUTES
---------------	-----------

### PARTS IDENTIFICATION

A		CHAIR SEAT	1PC
B		FOOT REST	1PC
C		GAS CYLINDER	1PC
D		CHAIR BASE	1PC
E		DECORATIVE RING	1PC

Z

### HARDWARE IDENTIFICATION

1		BOLT (M6x20mm)	4PCS
2		ALLEN WRENCH (M5)	1PC

#### Note:

Quantities shown are for one chair

# ITEM :100424 ASSEMBLY INSTRUCTIONS



## STEP 1

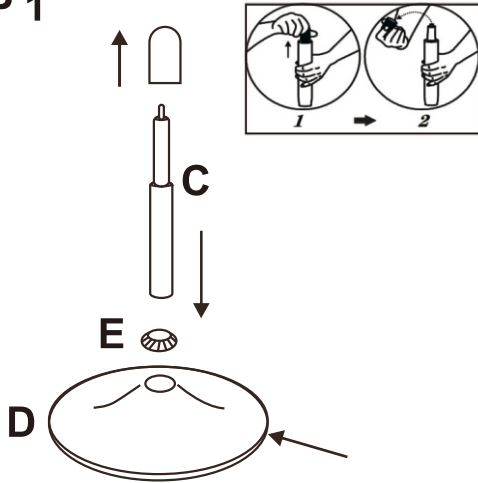

Place the chair seat (A) upside down on a soft surface. Then attach the foot rest (B) to the chair seat (A) using the bolt (1) and tighten with the allen wrench (2).

## STEP 2

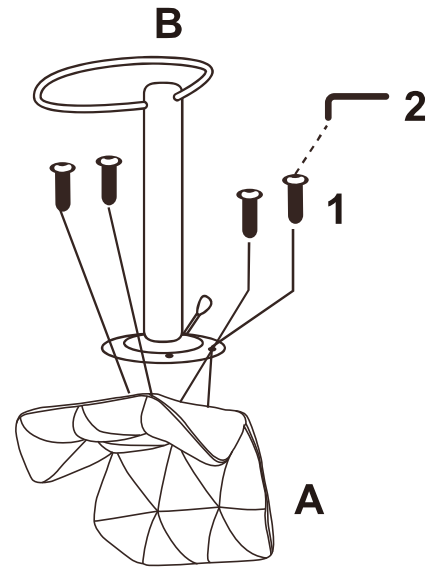

## STEP 3

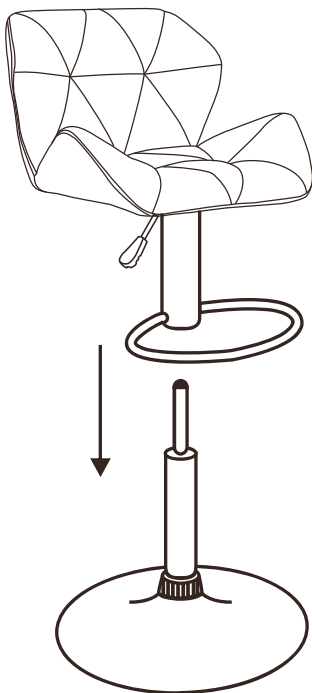

Connect the foot rest (B) and chair seat (A) to the gas cylinder (C) and the chair base (D), press firmly to the top of the gas spring. AS SHOWN IN THE DRAWING.

## STEP 4

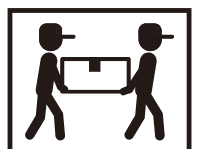
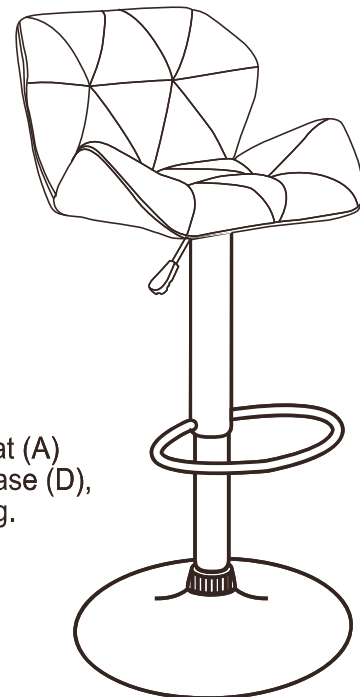

ITEM: 100424

ASSEMBLY INSTRUCTIONS

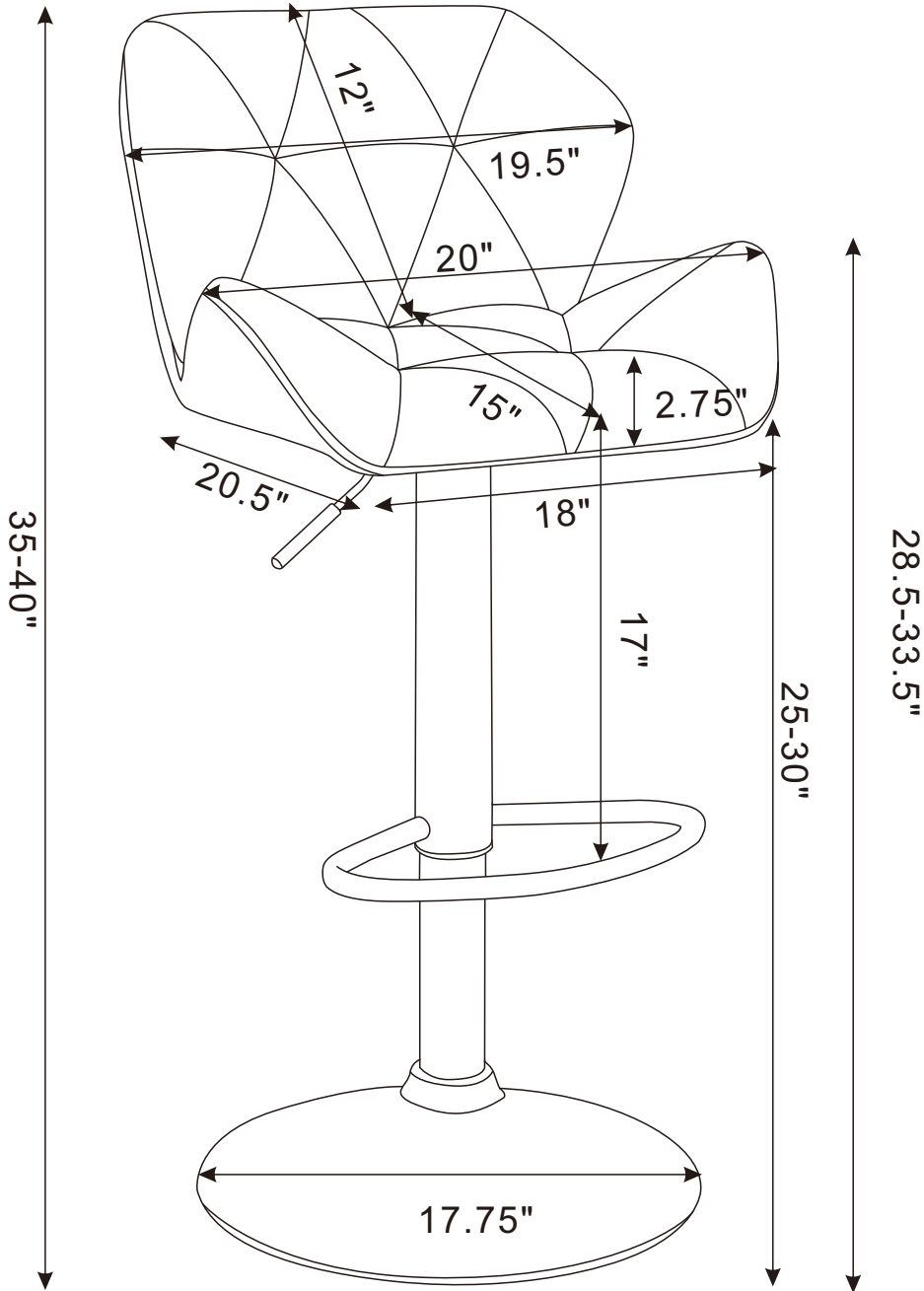

Noted: Dimension tolerance  $\pm 5\%$