



# ASSEMBLY INSTRUCTIONS COASTER FINE FURNITURE



*Fine Furniture for every stage of life*

## **360181KW (B1&B2)** ***California King Bed***

REVISION 0 : 11/11/2023

# ITEM : 360181KW (B1&B2)



## ASSEMBLY INSTRUCTIONS

### ASSEMBLY TIPS :

1. Remove hardware from box and sort by size.
2. Please check to see that all hardware and parts are present prior to start of assembly.
3. Please follow attached instructions in the same sequence as numbered to assure fast & easy assembly.



### WARNING!

1. Don't attempt to repair or modify parts that are broken or defective. Please contact the store immediately.
2. This product is for home use only and not intended for commercial establishments.

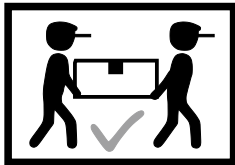

ASSEMBLY TIME

15 MINUTES

## PARTS IDENTIFICATION

### B1 (BOX 1)

A HEADBOARD

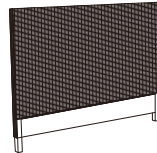

1PC

### B2 (BOX 2)

B FOOTBOARD



1PC

C BED RAIL



2PCS

D BED SLAT



4PCS

E BED SLAT SUPPORT WITH LEVELER



8PCS

A 360181Q (B1) FROM BOX 1 HEADBOARD



1PC

## HARDWARE IDENTIFICATION

### Z-B2 (BOX 2) - HARDWARE PACK IS LOCATED IN 360181KW (B2)

1 LONG BOLT  
(Ø5/16" x 1-1/8" - BLK)

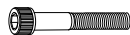

8PCS

2 LOCK WASHER  
(Ø5/16" - RBW)



8PCS

3 FLAT WASHER  
(Ø5/16" - RBW)



8PCS

4 ALLEN WRENCH  
(6MM - BLK)



1PC

5 FLAT HEAD SCREW  
(Ø5/16" x 1-3/4" - RBW)



8PCS

### NOTE:

Phillips head screw driver is required in the assembly process; however, manufacturer does not provide this item.

# ITEM : 360181KW (B1&B2)

## ASSEMBLY INSTRUCTIONS

### STEP 1

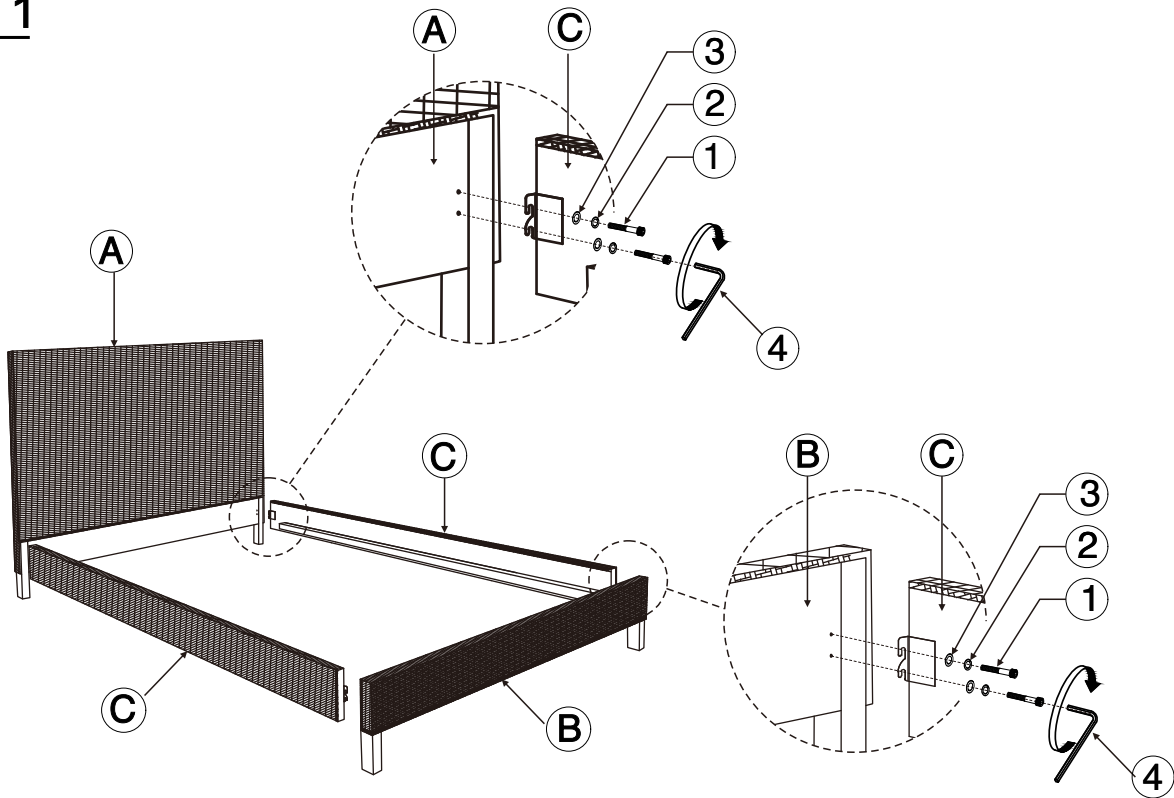

### STEP 2

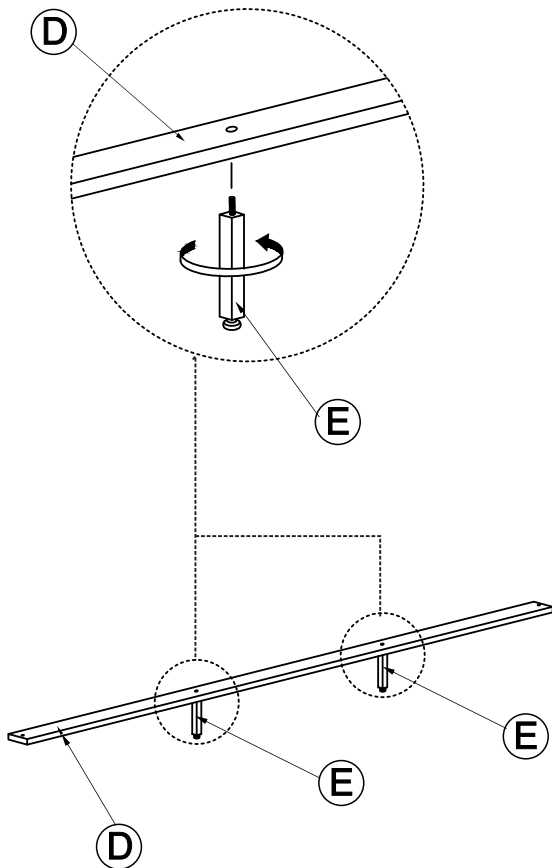

### STEP 3 COMPLETE

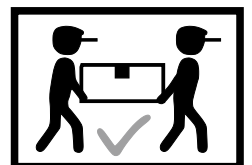
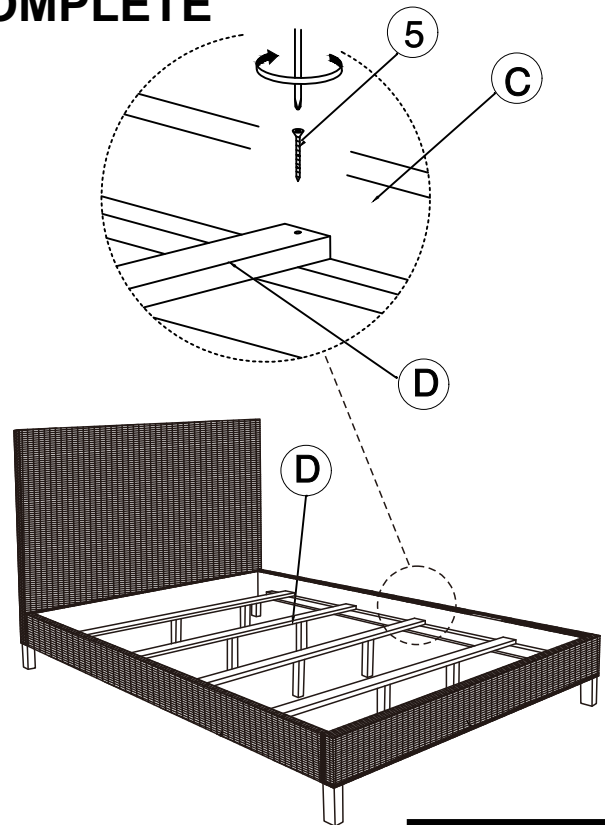

# ITEM : 360181KW (B1&B2)

## ASSEMBLE HEADBOARD TO METAL FRAME

### ASSEMBLY TIPS :

1. Remove hardware from box and sort by size.
2. Please check to see that all hardware and parts are present prior to start of assembly.
3. Please follow attached instructions in the same sequence as numbered to assure fast & easy assembly.



### WARNING!

1. Don't attempt to repair or modify parts that are broken or defective. Please contact the store immediately.
2. This product is for home use only and not intended for commercial establishments.

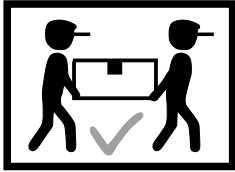

ASSEMBLY TIME

15 MINUTES

## PARTS IDENTIFICATION

### B1 (BOX 1)

A



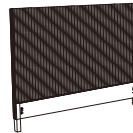



HEADBOARD

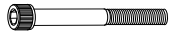

1PC

## HARDWARE IDENTIFICATION

### Z - B1 (BOX 1) - HARDWARE PACK IS LOCATED IN 360181KW (B1)

6	<b>LONG BOLT</b> ( Ø7/23" x 2-3/8" - BLK )		6PCS
7	<b>LOCK WASHER</b> ( Ø4/16" - RBW )		6PCS
8	<b>FLAT WASHER</b> ( Ø4/16" - RBW )		12PCS
9	<b>ALLEN WRENCH</b> ( 4mm - BLK )		1PC
10	<b>HEX NUT</b> ( M 6mm - BLK )		6PCS
11	<b>WRENCH</b> ( 3-3/8" x 1-1/8" - RBW )		1PC

# ITEM : 360181KW (B1&B2)

## ASSEMBLE HEADBOARD TO METAL FRAME COMPLETE

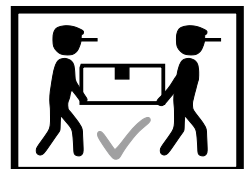
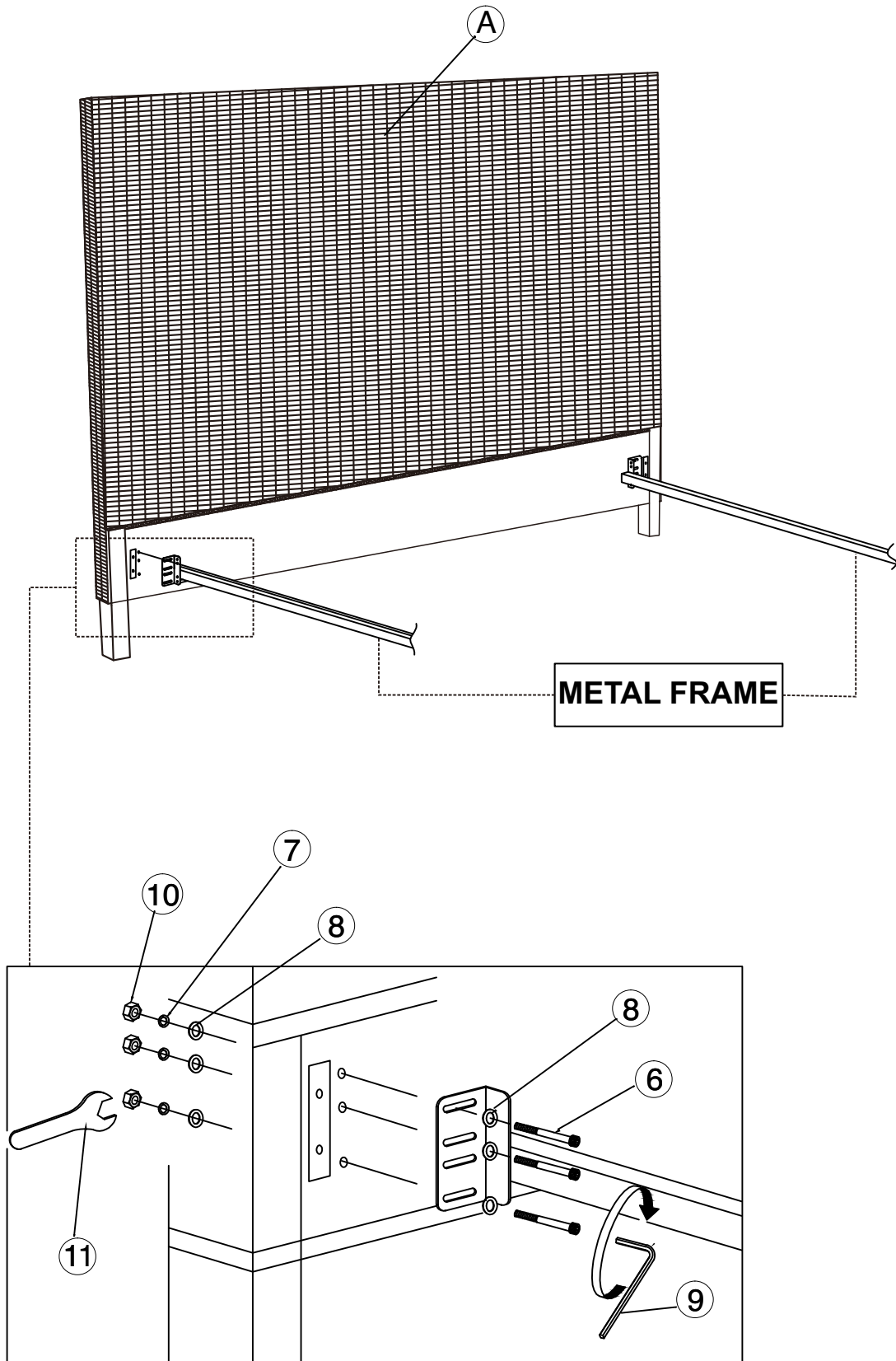

# ITEM : 360181KW (B1&B2)

Inner Size : 73.50"W x 85.50"D

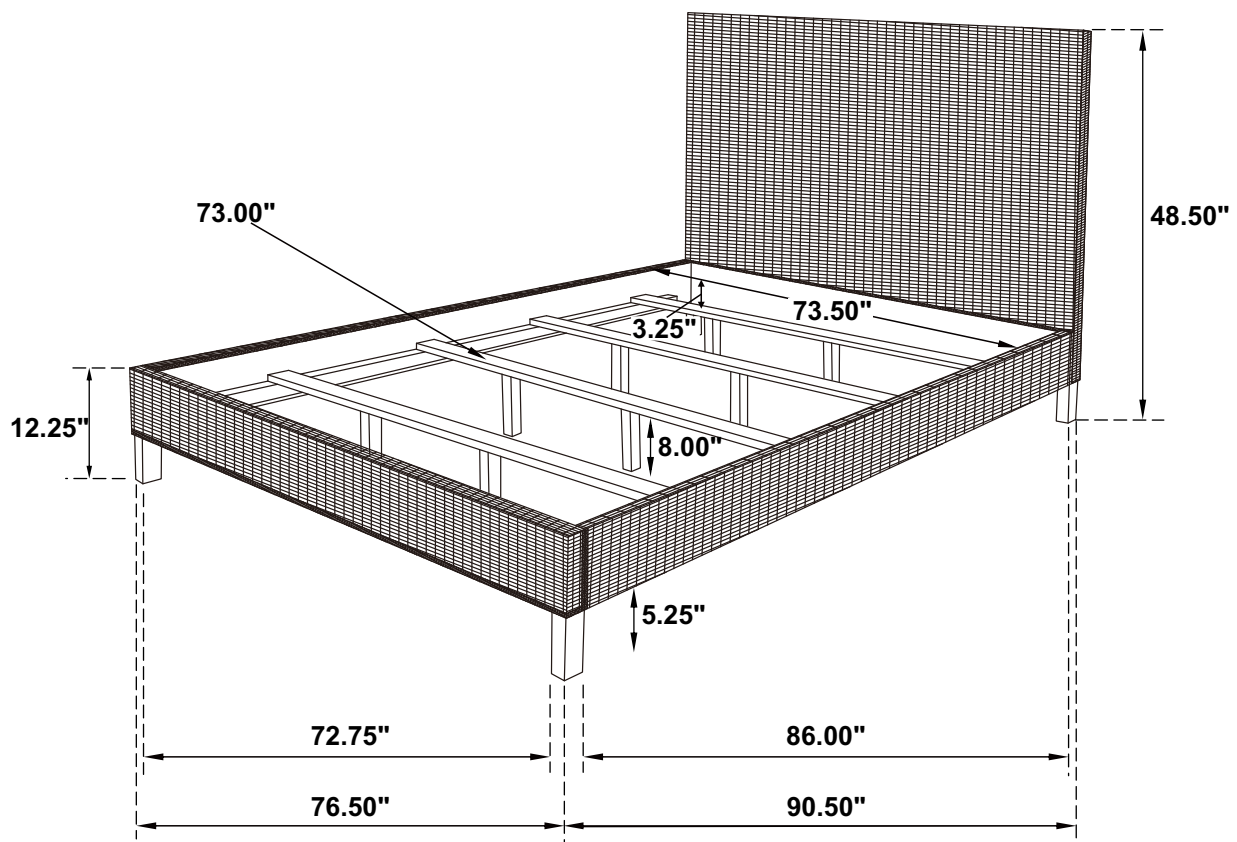

Note : Dimension tolerance  $\pm 5\%$