



*ASSEMBLY INSTRUCTIONS*  
*COASTER FINE FURNITURE*



*Fine Furniture for every stage of life*

**183471**  
***Counter Height Chair***

# ITEM: 183471



## ASSEMBLY INSTRUCTIONS

### ASSEMBLY TIPS :

1. Remove hardware from box and sort by size.
2. Please check to see that all hardware and parts are present prior to start of assembly.
3. Please follow attached instructions in the same sequence as numbered to assure fast & easy assembly.



### WARNING !

1. Don't attempt to repair or modify parts that are broken or defective. Please contact the store immediately.
2. This product is for home use only and not intended for commercial establishments.

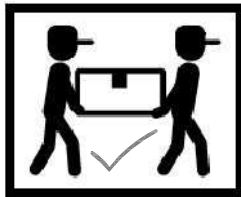

ASSEMBLY TIME

20 MINUTES

## PARTS IDENTIFICATION

A	BACK FRAME		1PC
B	LEFT FRONT LEG		1PC
C	RIGHT FRONT LEG		1PC
D	FRONT STRETCHER		1PC
E	RIGHT SIDE STRETCHER		1PC
F	LEFT SIDE STRETCHER		1PC
G	SEAT CUSHION WITH FRAME		1PC

## HARDWARE IDENTIFICATION

1	ALLEN WRENCH (M4 x 110MM - BLK)		1PC
2	LONG BOLT (M6 x 80MM - RBW)		4PCS
3	MEDIUM BOLT (M6 x 60MM - RBW)		4PCS
4	SHORT BOLT (M6 x 40MM - RBW)		2PCS
5	LOCK WASHER (1/4" - BLK)		10PCS
6	FLAT WASHER (5/16" - RBW)		10PCS
7	PAN HEAD SCREW (#8 X 1 1/2" - BLK)		6PCS

### NOTE :

Phillips head screw driver is required in the assembly process ; However, manufacturer does not provide this item. Quantities shown are for one chair.

ITEM: **183471**

**ASSEMBLY INSTRUCTIONS**



**STEP 1**

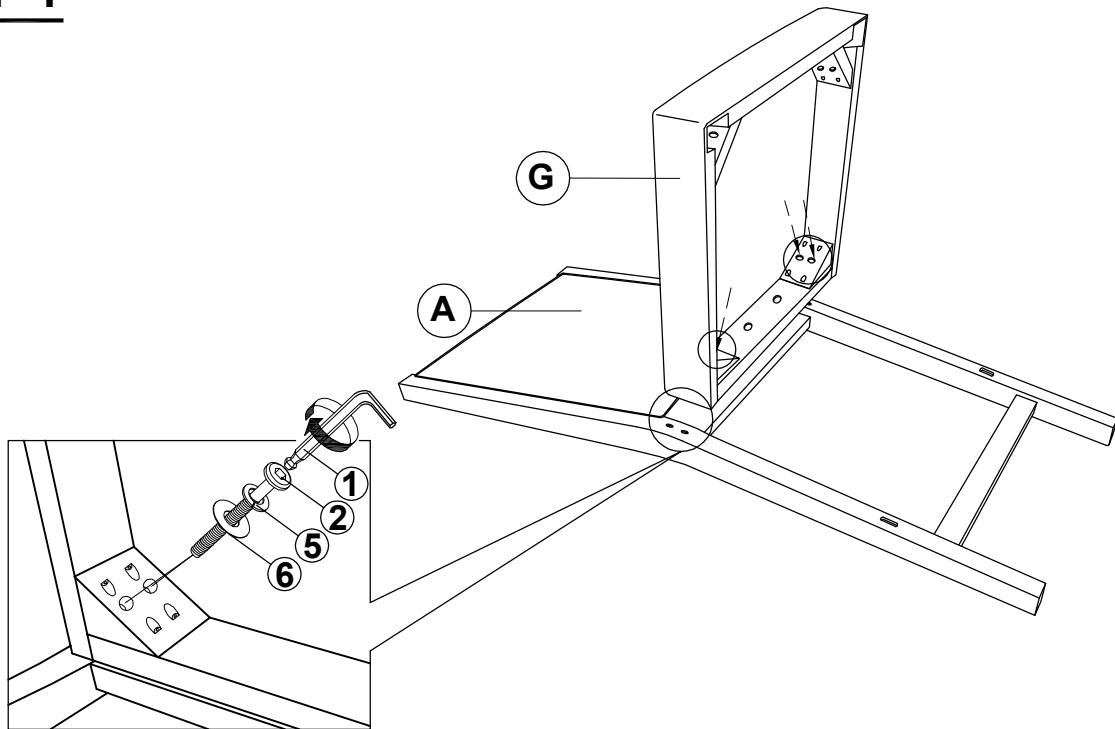

**STEP 2**

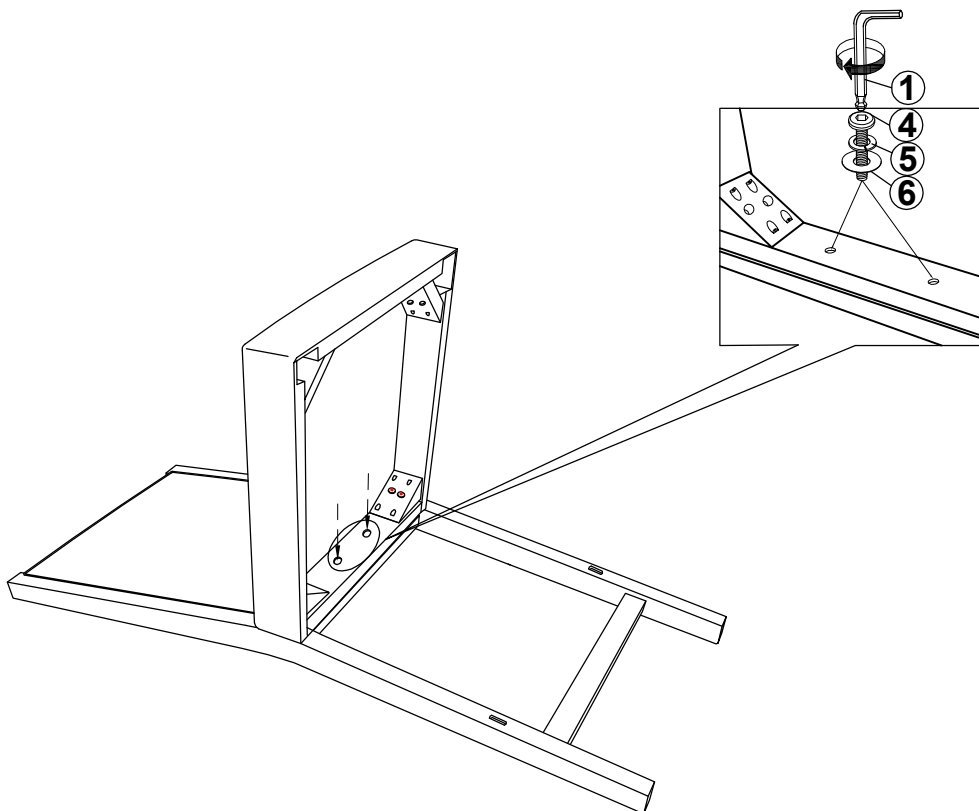

ITEM: **183471**

**ASSEMBLY INSTRUCTIONS**

**STEP 3**



**BOTTOM VIEW**

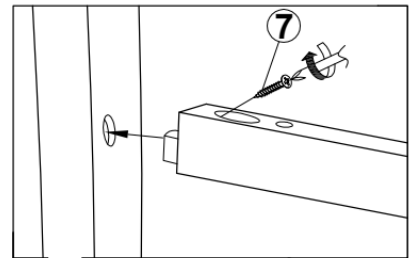

**BOTTOM VIEW**

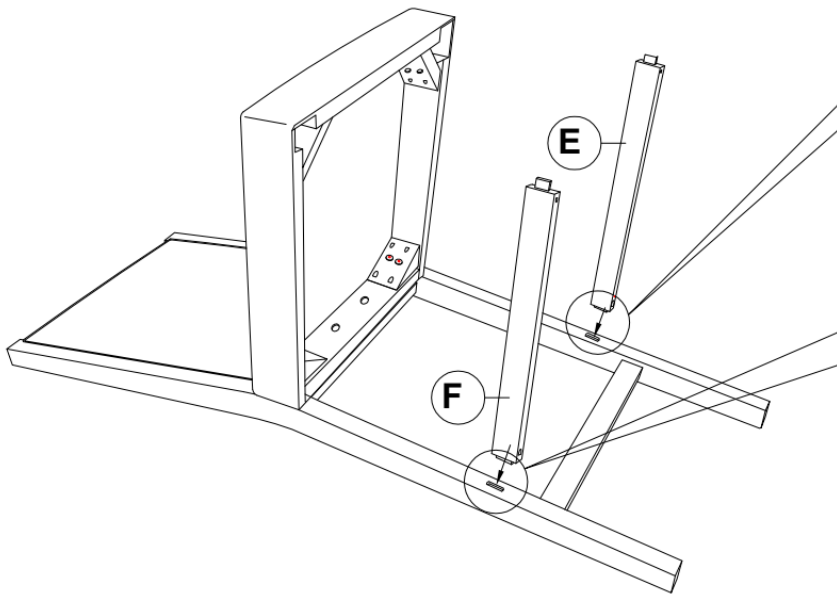
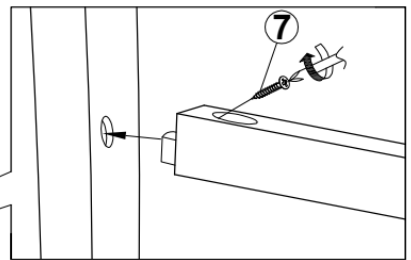

**STEP 4**

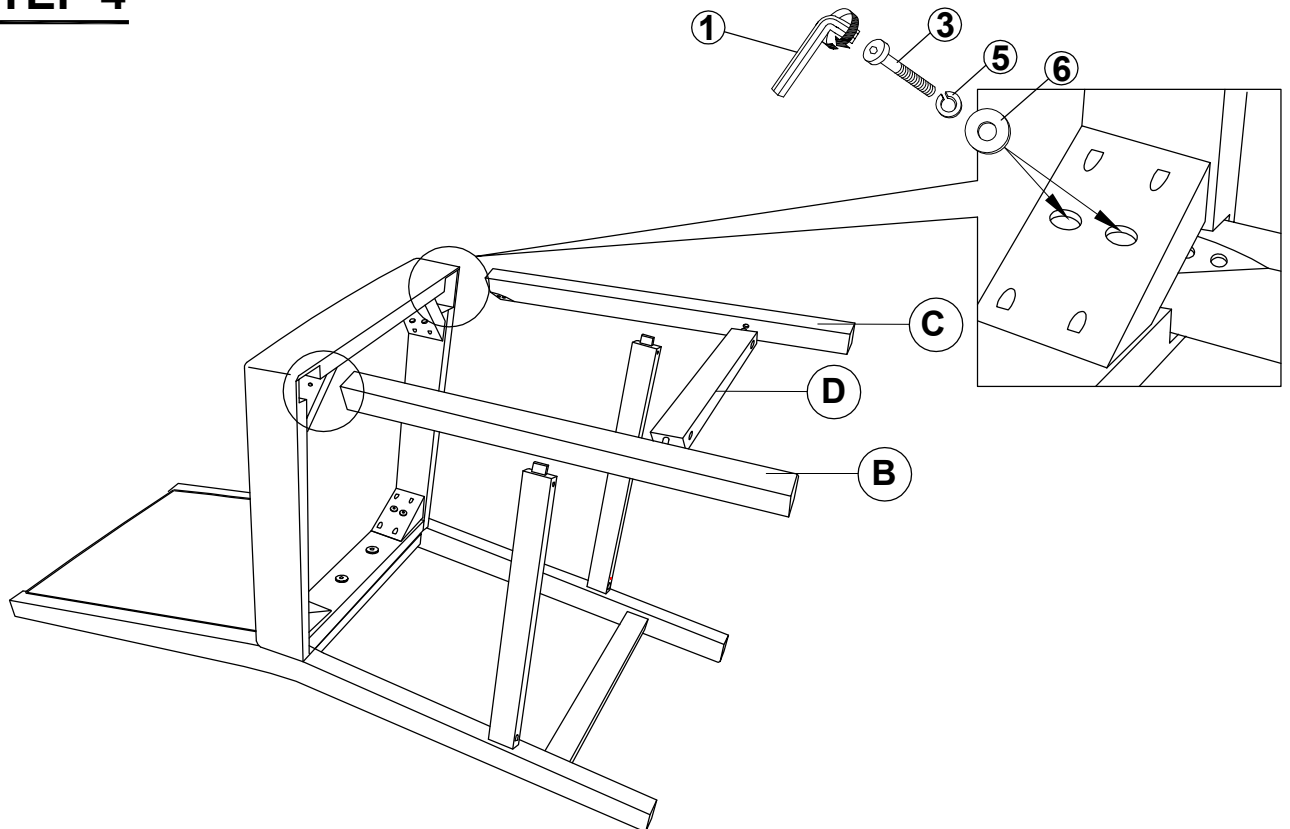

ITEM: **183471**

**ASSEMBLY INSTRUCTIONS**  
**STEP 5**

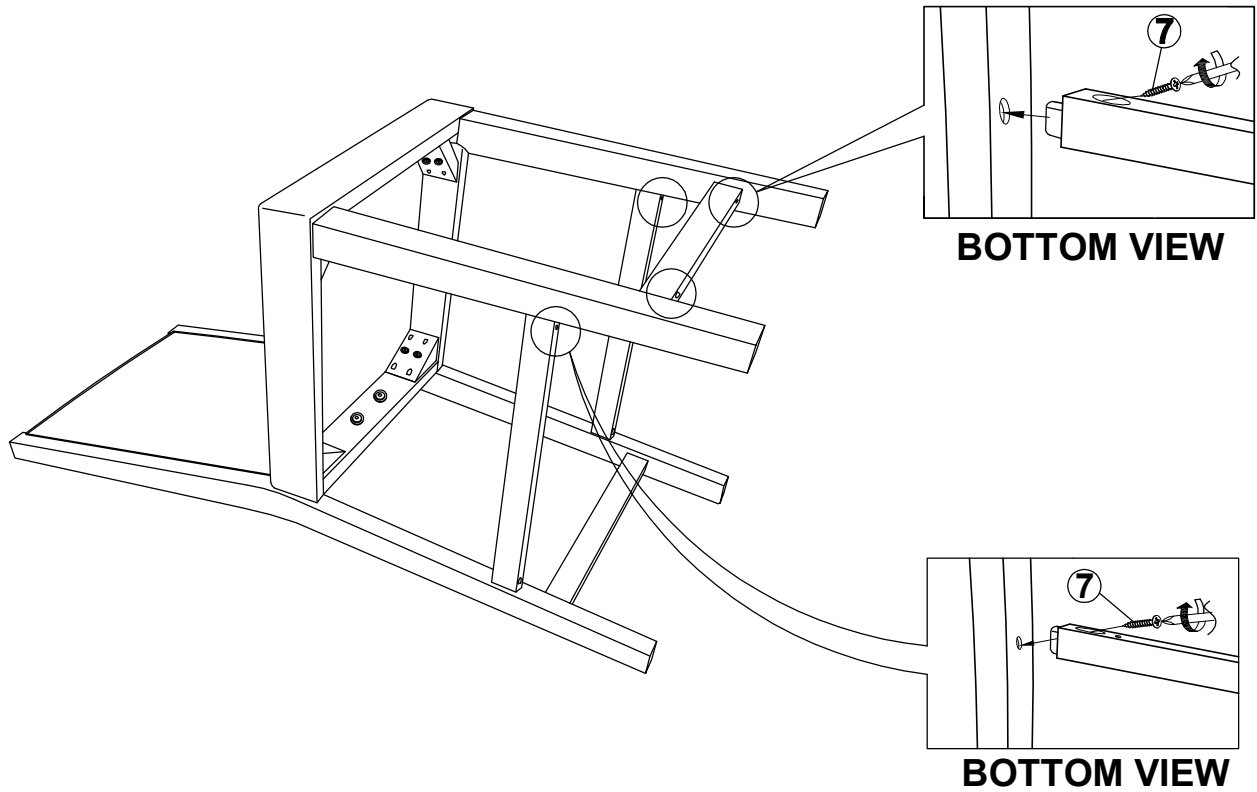

**STEP 6**  
**COMPLETE**

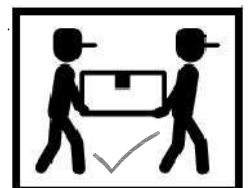
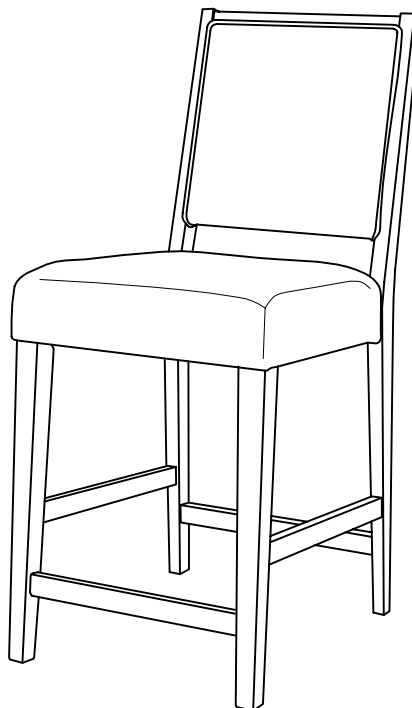

ITEM: 183471

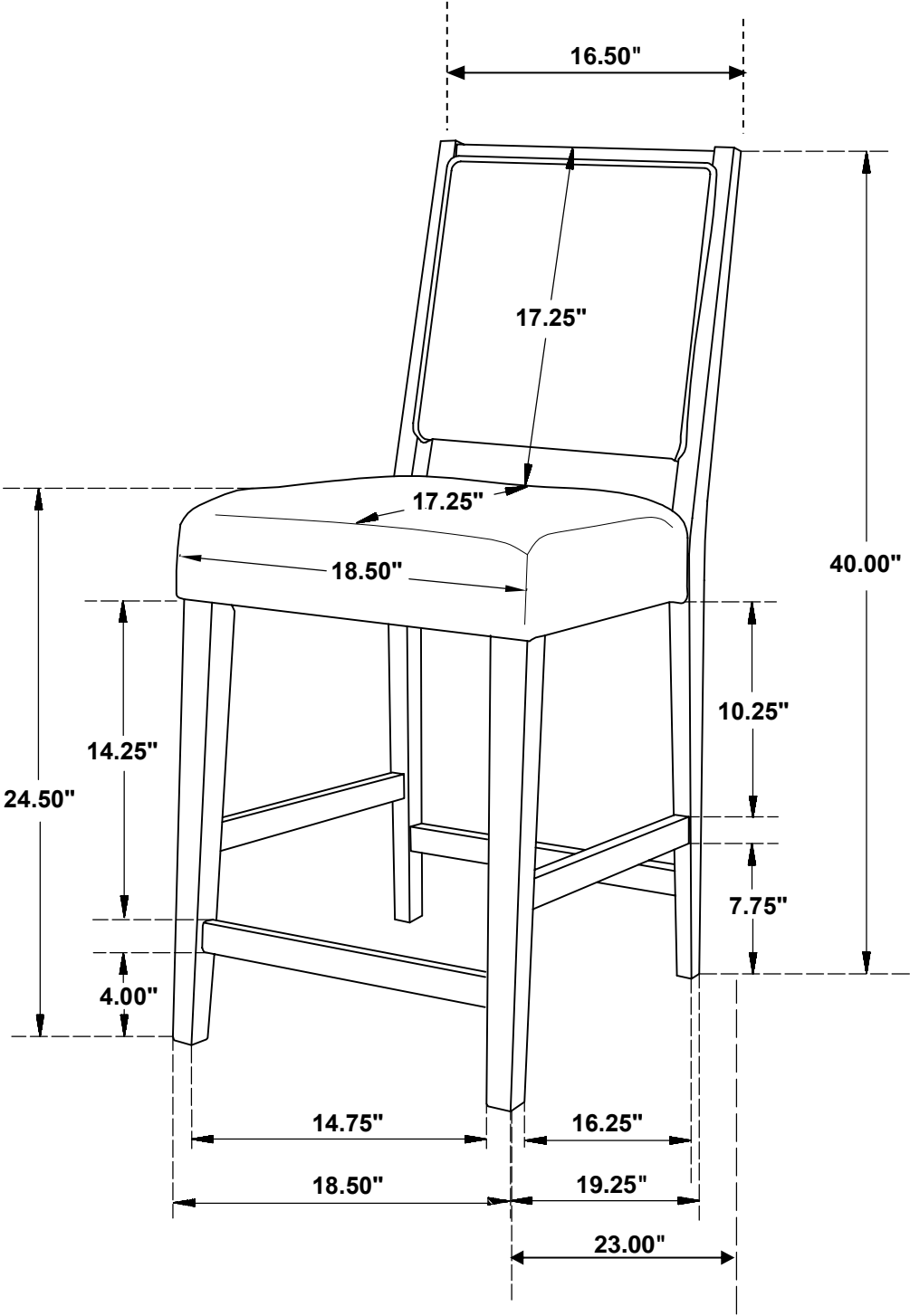

Note: Dimension tolerance  $\pm 5\%$