

ASSEMBLY INSTRUCTIONS
COASTER FINE FURNITURE



Fine Furniture for every stage of life

190822
Dining Side Chair

ITEM: 190822



ASSEMBLY INSTRUCTIONS

ASSEMBLY TIPS :

1. Remove hardware from box and sort by size.
2. Please check to see that all hardware and parts are present prior to start of assembly.
3. Please follow attached instructions in the same sequence as numbered to assure fast & easy assembly.



WARNING !

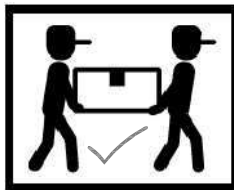

1. Don't attempt to repair or modify parts that are broken or defective. Please contact the store immediately.
2. This product is for home use only and not intended for commercial establishments.





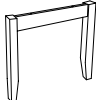

ASSEMBLY TIME

15 MINUTES

PARTS IDENTIFICATION

A	BACK FRAME		1PC
B	FRONT LEG FRAME		1PC
C	SIDE RAIL		2PCS
D	SEAT CUSHION		1PC

HARDWARE IDENTIFICATION

1	ALLEN WRENCH (M4 x 110MM - BLK)		1PC
2	BOLT (M6 x 50MM - RBW)		6PCS
3	LOCK WASHER (1/4" - BLK)		6PCS
4	FLAT WASHER (M6 x 13MM - RBW)		6PCS
5	PAN HEAD SCREW (#8 x 1" - BLK)		4PCS

NOTE :

Phillips head screw driver is required in the assembly process; however, manufacturer not provide this item. Quantities shown are for one chair.

ITEM: **190822**



ASSEMBLY INSTRUCTIONS

STEP 1

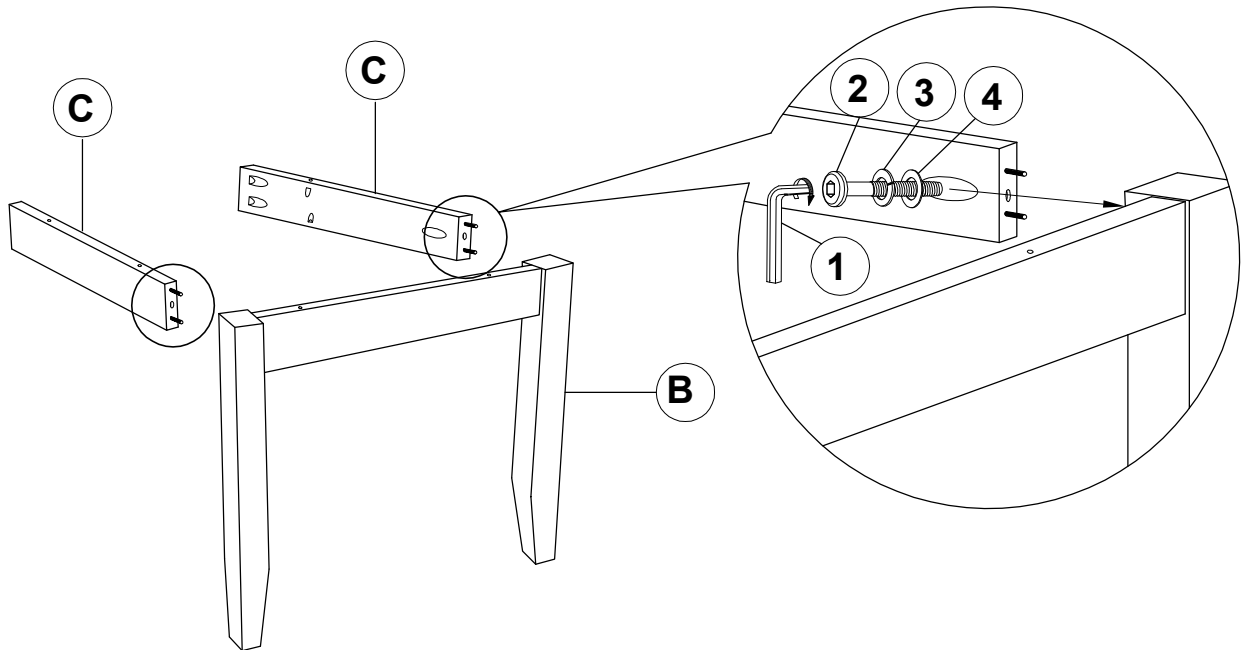

STEP 2

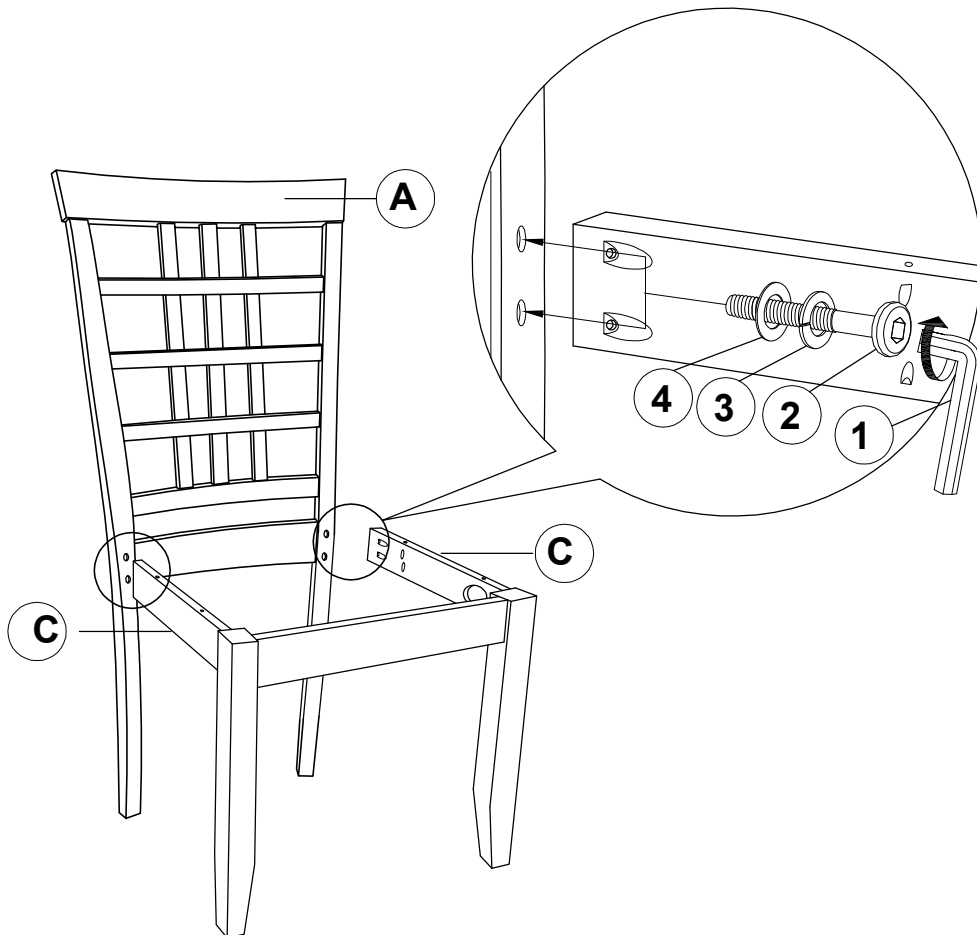

ITEM: **190822**



ASSEMBLY INSTRUCTIONS

STEP 3

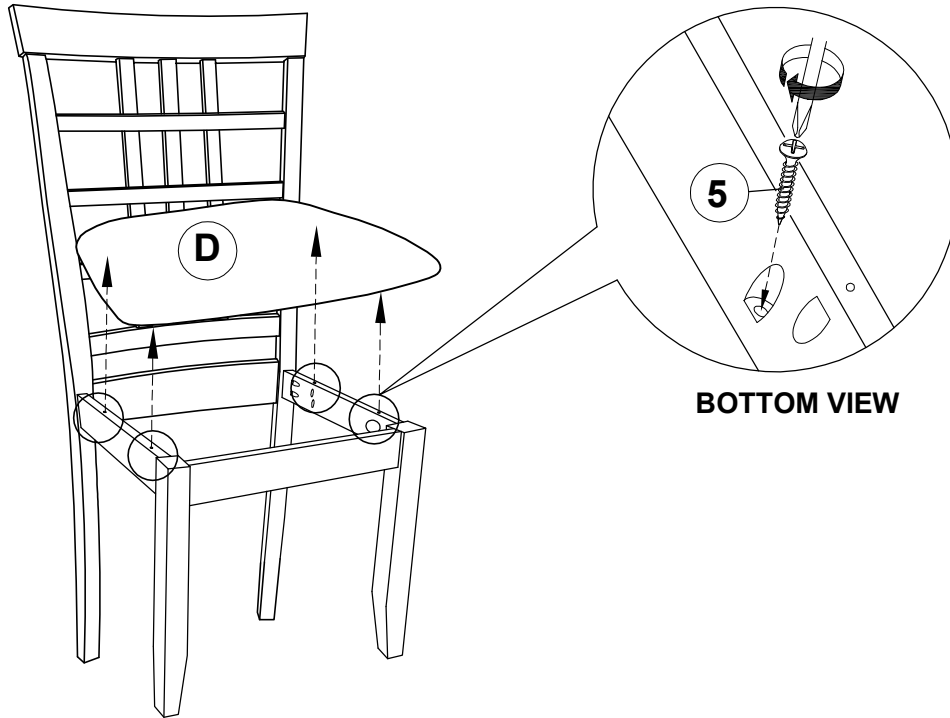

STEP 4
COMPLETE

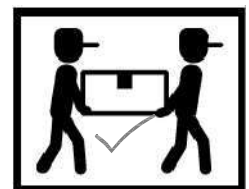

ITEM: **190822**

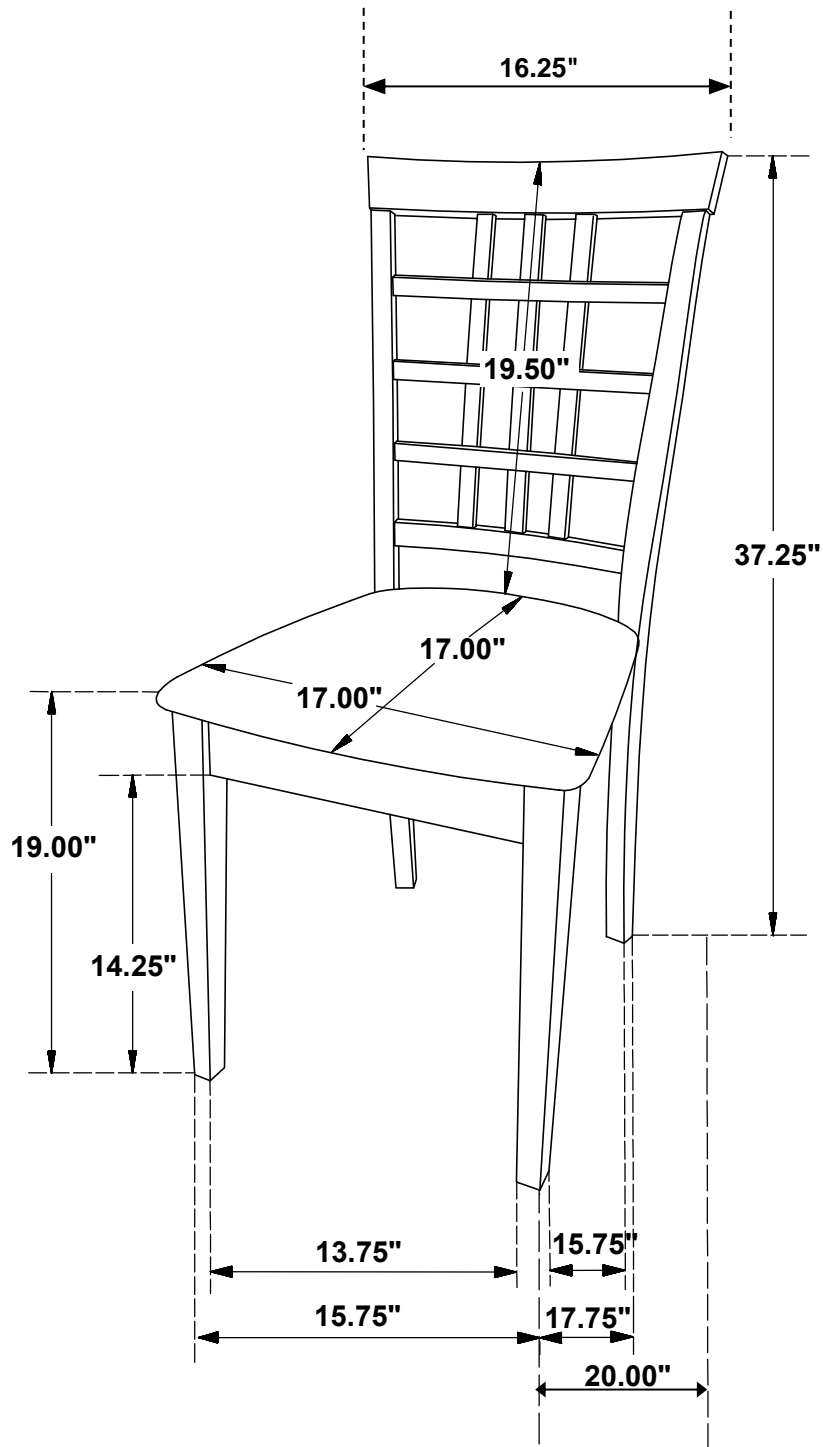

Note: Dimension tolerance $\pm 5\%$