

ASSEMBLY INSTRUCTIONS
COASTER FINE FURNITURE

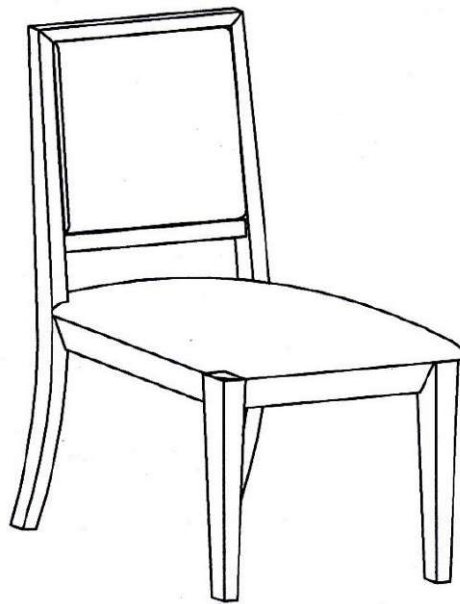

Fine Furniture for every stage of life

101562
Dining Side Chair

REVISION 0 : 10/10/2009
REVISION 1 : 10/25/2010
REVISION 2 : 02/16/2012
REVISION 3 : 08/23/2018
REVISION 4 : 07/03/2019
REVISION 5 : 03/03/2022

ITEM: **101562**



ASSEMBLY INSTRUCTIONS

ASSEMBLY TIPS:

1. Remove hardware from box and sort by size.
2. Please check to see that all hardware and parts are present prior to start of assembly.
3. Please follow attached instructions in the same sequence as numbered to assure fast & easy assembly.



WARNING!





1. Don't attempt to repair or modify parts that are broken or defective. Please contact the store immediately.
2. This product is for home use only and not intended for commercial establishments.





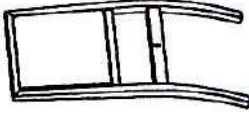

ASSEMBLY TIME

15 MINUTES

PARTS IDENTIFICATION

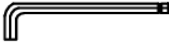
AF	BACK FRAME		1PC
B	FRONT LEG FRAME		1PC
C	LEFT SIDE RAIL		1PC
D	RIGHT SIDE RAIL		1PC
EF	SEAT CUSHION		1PC

HARDWARE IDENTIFICATION

1	ALLEN WRENCH (M4 - BLK)		1PC
2	BOLT (M6 x 50mm - RBW)		6PCS
3	HALF ROUND NUT (3/5" x 3/5" - BLK)		6PCS
4	FLAT HEAD SCREW (M4 x 25mm - RBW)		4PCS

NOTE:

Quantities shown are for one chair.

Phillips head screw driver is required in the assembly process; however, manufacturer does not provide this item.

ITEM: **101562**

ASSEMBLY INSTRUCTIONS
STEP 1

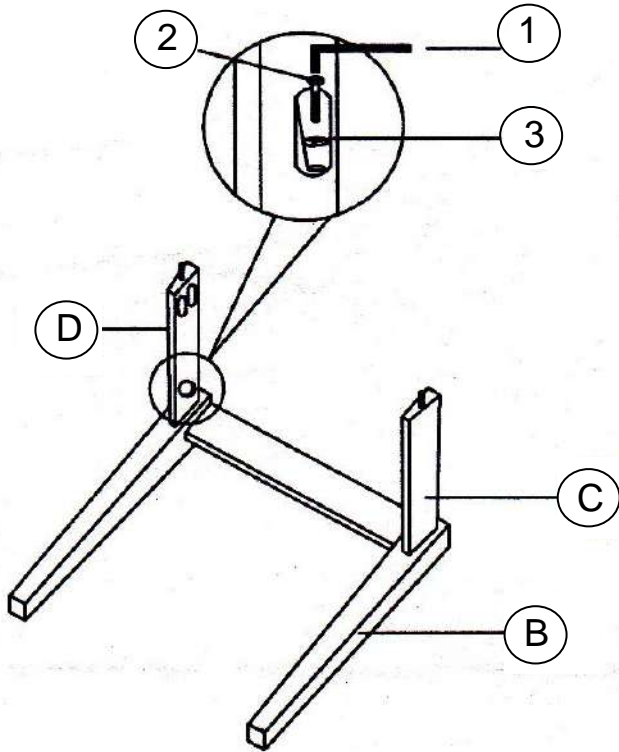

STEP 2

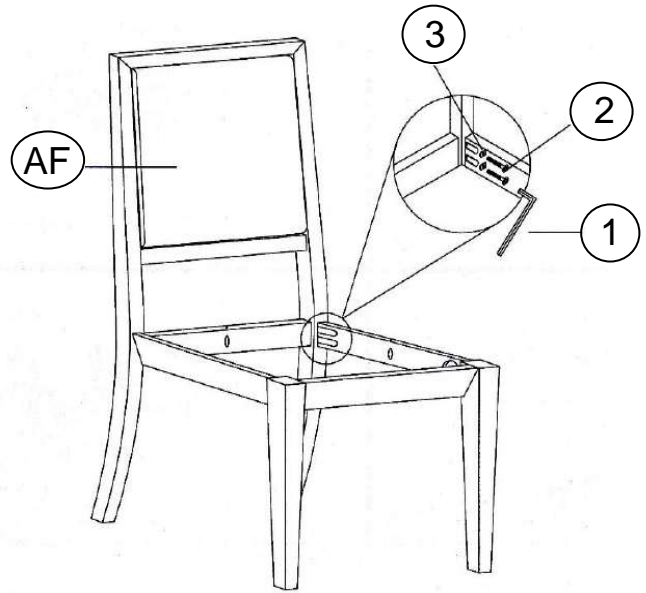

STEP 3

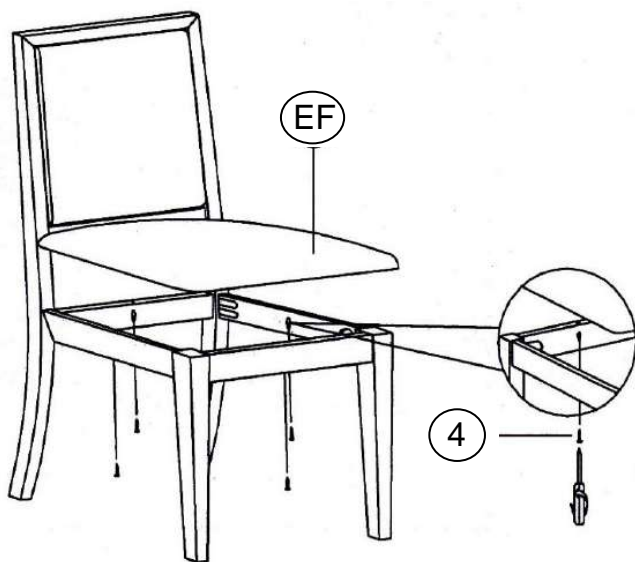

STEP 4
COMPLETE

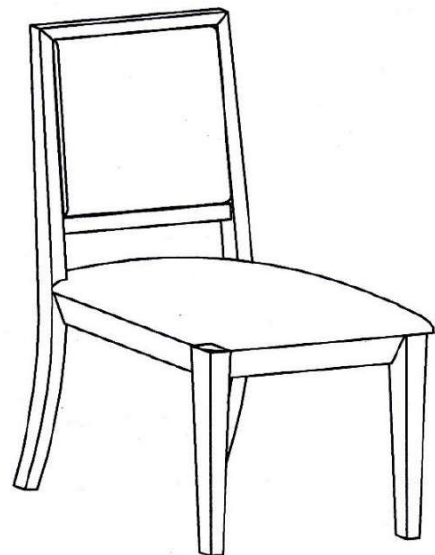

ITEM: 101562

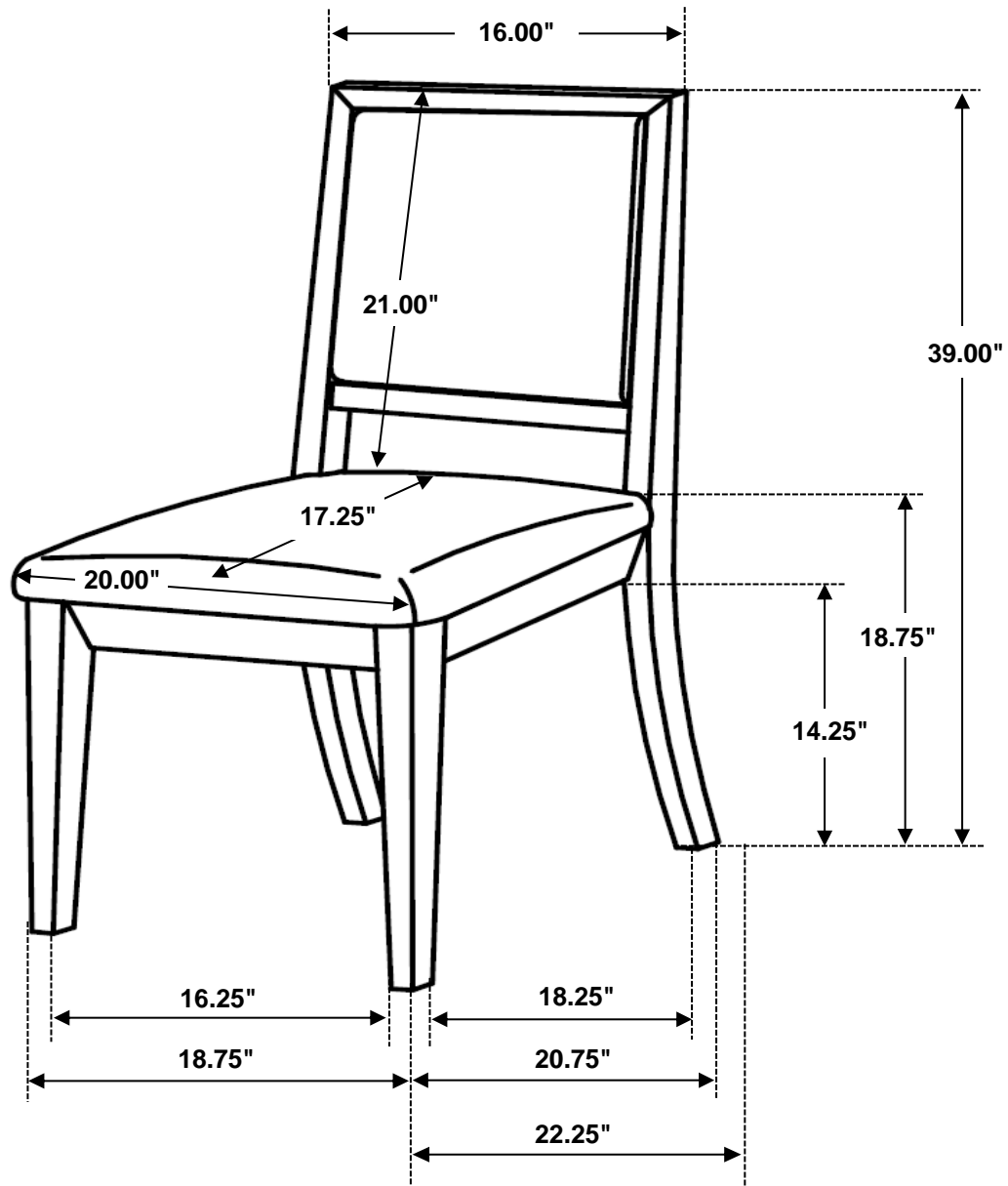

Note: Dimension tolerance $\pm 5\%$