



ASSEMBLY INSTRUCTIONS
COASTER FINE FURNITURE



Fine Furniture for every stage of life

108082
Dining Chair

REVISION 0: 12/01/2017
REVISION 1: 01/08/2018
REVISION 2: 03/11/2020

PAGE 1 OF 5

COASTERFURNITURE.COM

ITEM: **108082**



ASSEMBLY INSTRUCTIONS

ASSEMBLY TIPS :

1. Remove hardware from box and sort by size.
2. Please check to see that all hardware and parts are present prior to start of assembly.
3. Please follow attached instructions in the same sequence as numbered to assure fast & easy assembly.



WARNING !



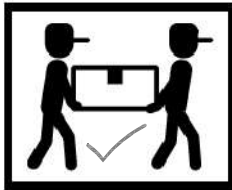

1. Don't attempt to repair or modify parts that are broken or defective. Please contact the store immediately.
2. This product is for home use only and not intended for commercial establishments.







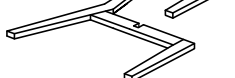



ASSEMBLY TIME

10 MINUTES

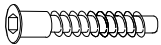
PARTS IDENTIFICATION

A	BACKREST		1PC
B	UPPER LEG FRAME		1PC
C	LOWER LEG FRAME		1PC
D	SEAT CUSHION		1PC
E	WOOD CLEAT		1PC

HARDWARE IDENTIFICATION

1	ALLEN WRENCH (M4 x 110mm - BLK)		1PC
2	LONG BOLT (M6 x 60mm - RBW)		4PCS
3	HEX BOLT (M7 x 50mm - ZB)		1PC
4	MEDIUM BOLT (M6 x 35mm - RBW)		4PCS
5	SHORT BOLT (M6 x 25mm - RBW)		4PCS
6	LOCK WASHER (1/4" - BLK)		8PCS
7	FLAT WASHER (M6 x 13mm - RBW)		4PCS
8	WOOD PLUG (Ø14.5 x 9mm)		4PCS

NOTE :

Quantities shown are for one chair.

ITEM: **108082**
ASSEMBLY INSTRUCTIONS

STEP 1

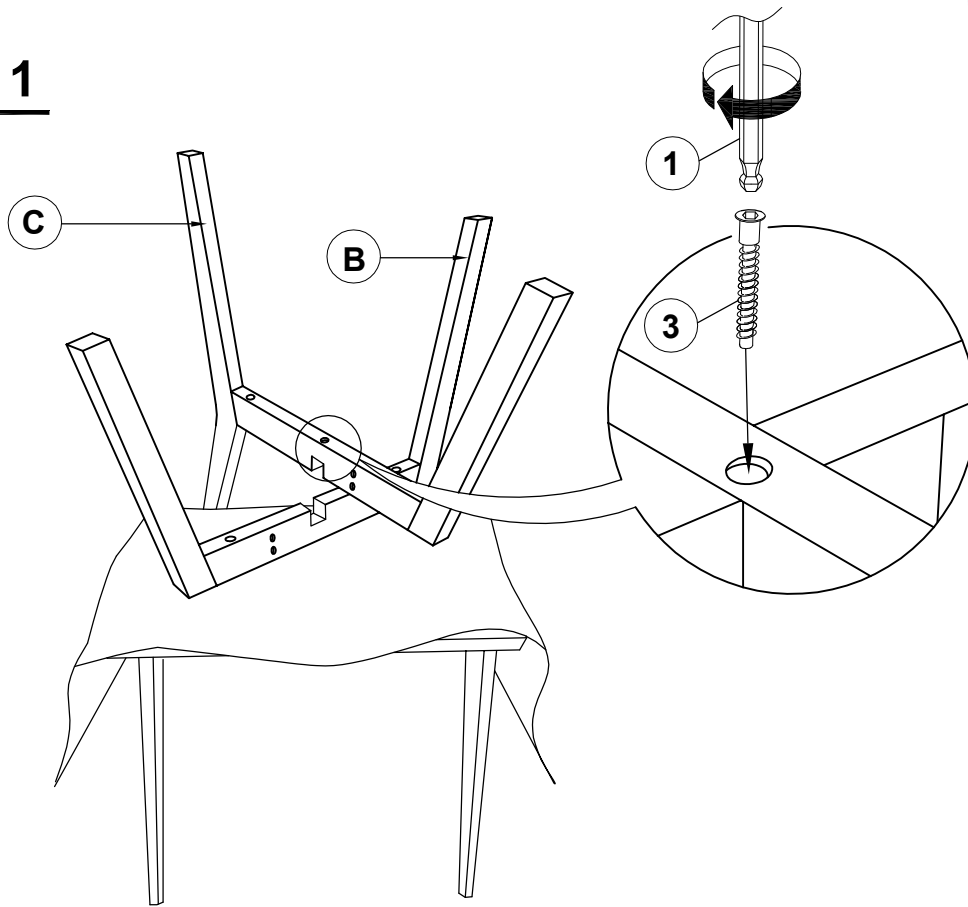

STEP 2

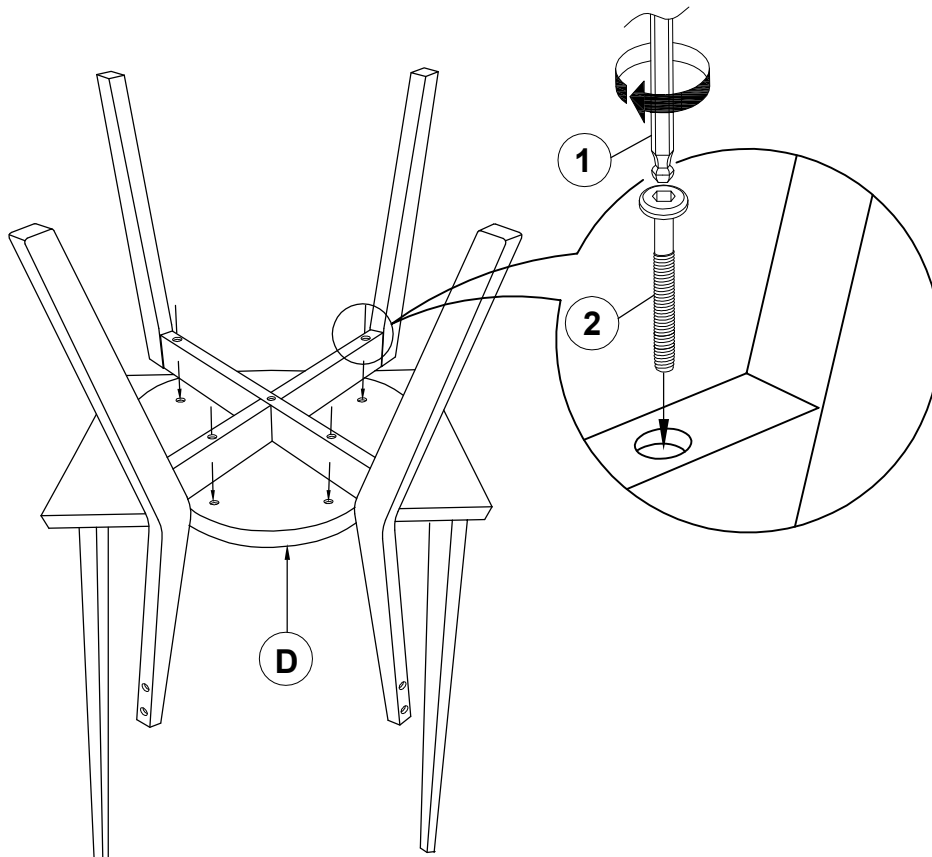

ITEM: **108082**

ASSEMBLY INSTRUCTIONS



STEP 3

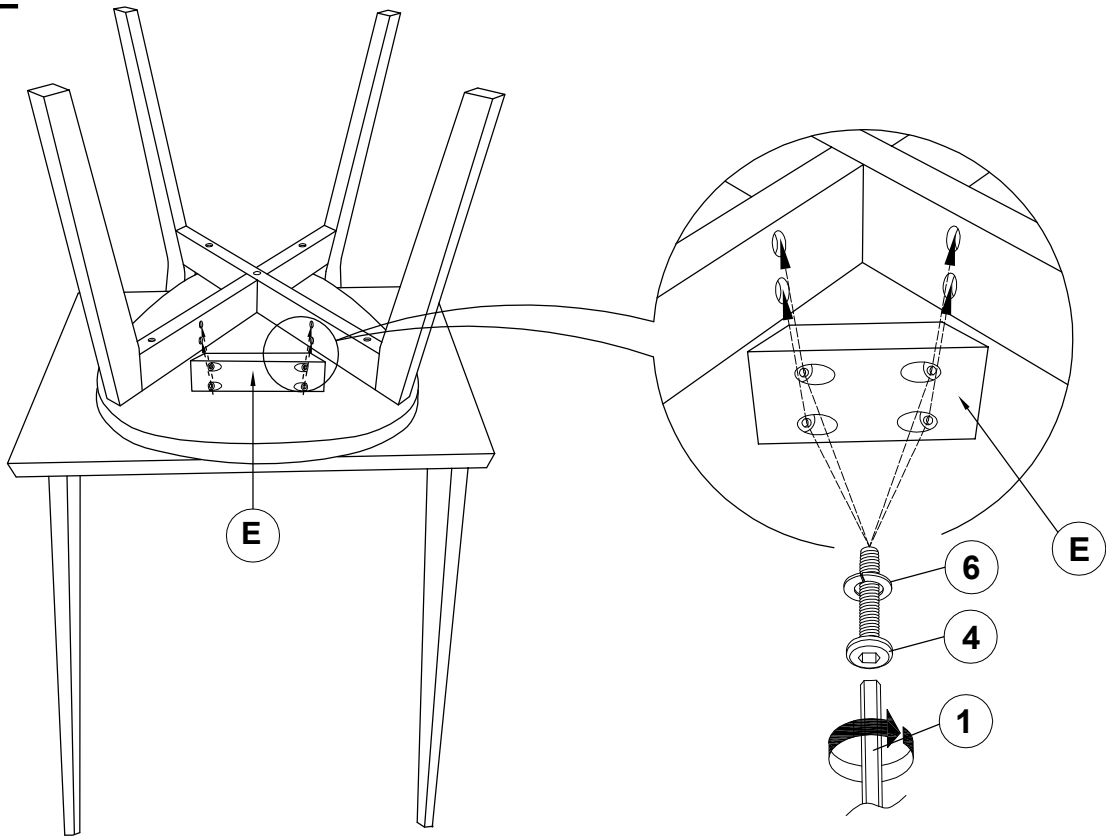

STEP 4

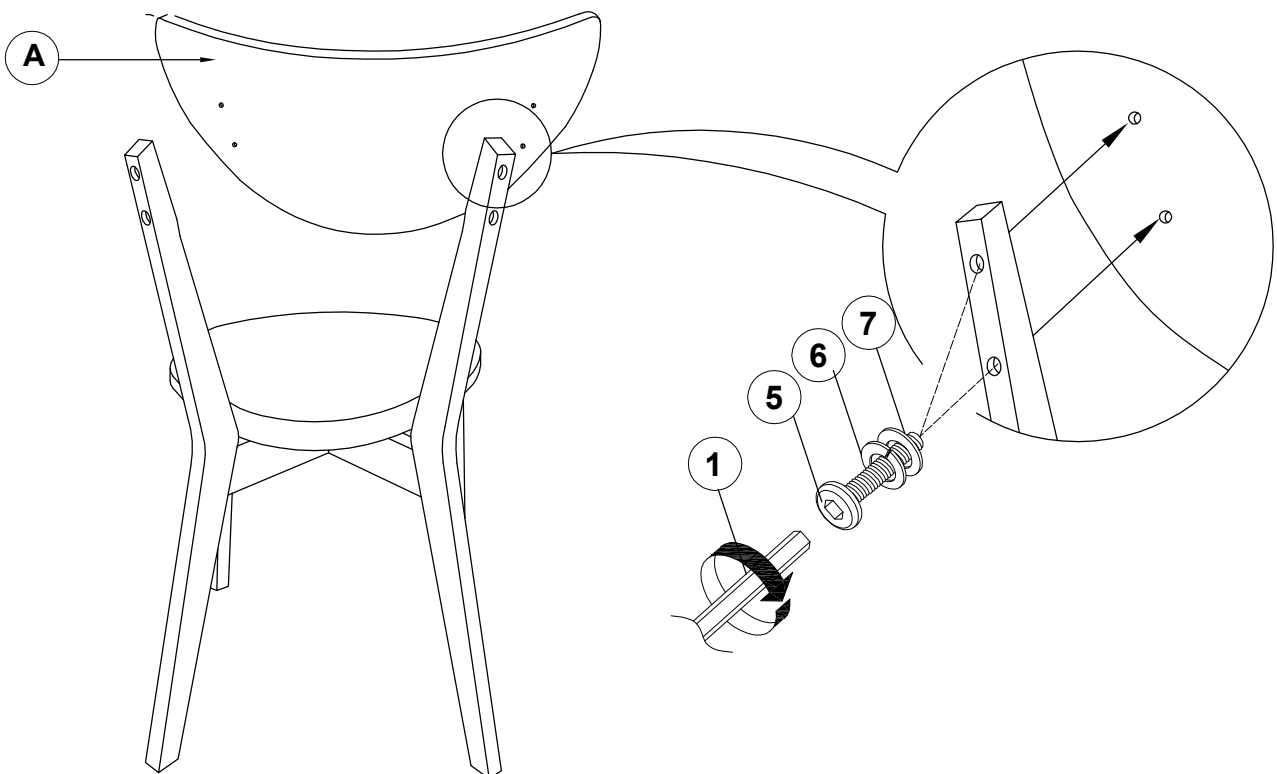

ITEM: **108082**
ASSEMBLY INSTRUCTIONS



STEP 5

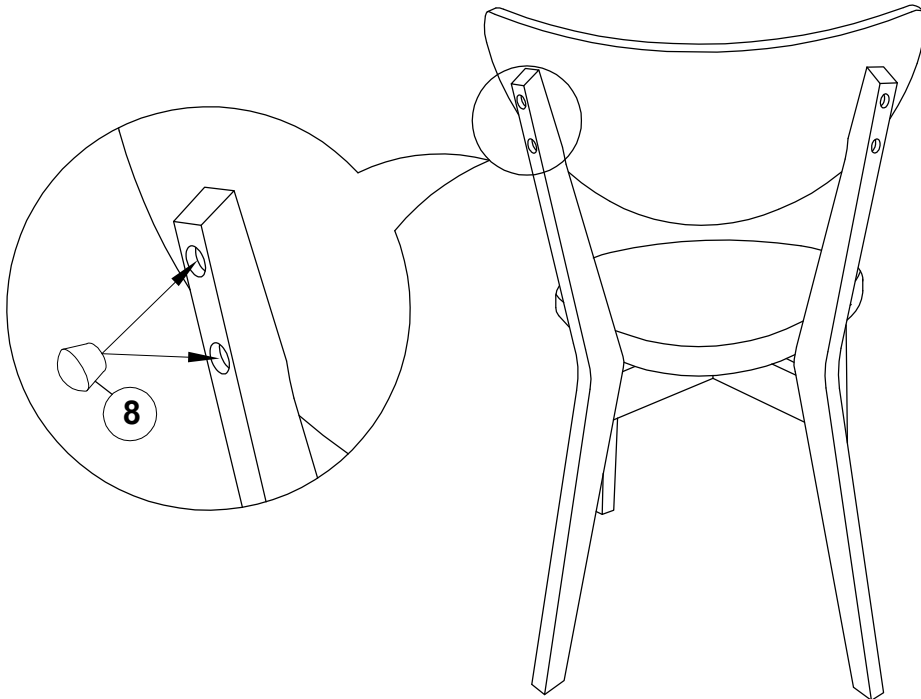

STEP 6
COMPLETE

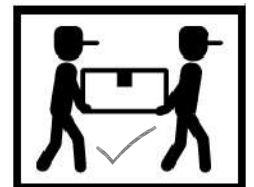
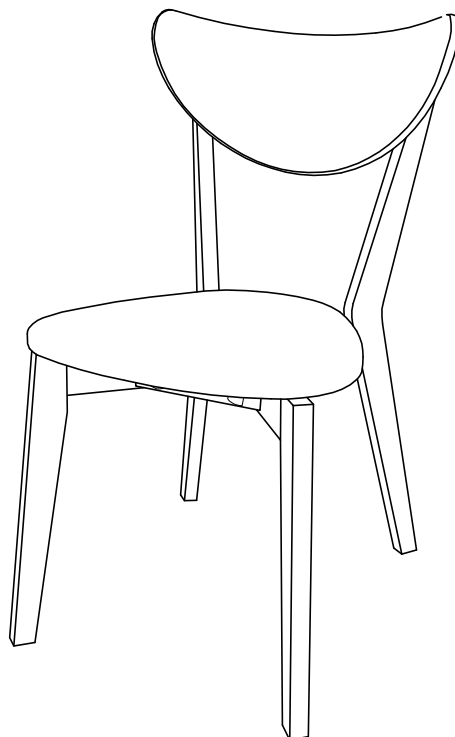

ITEM: **108082**

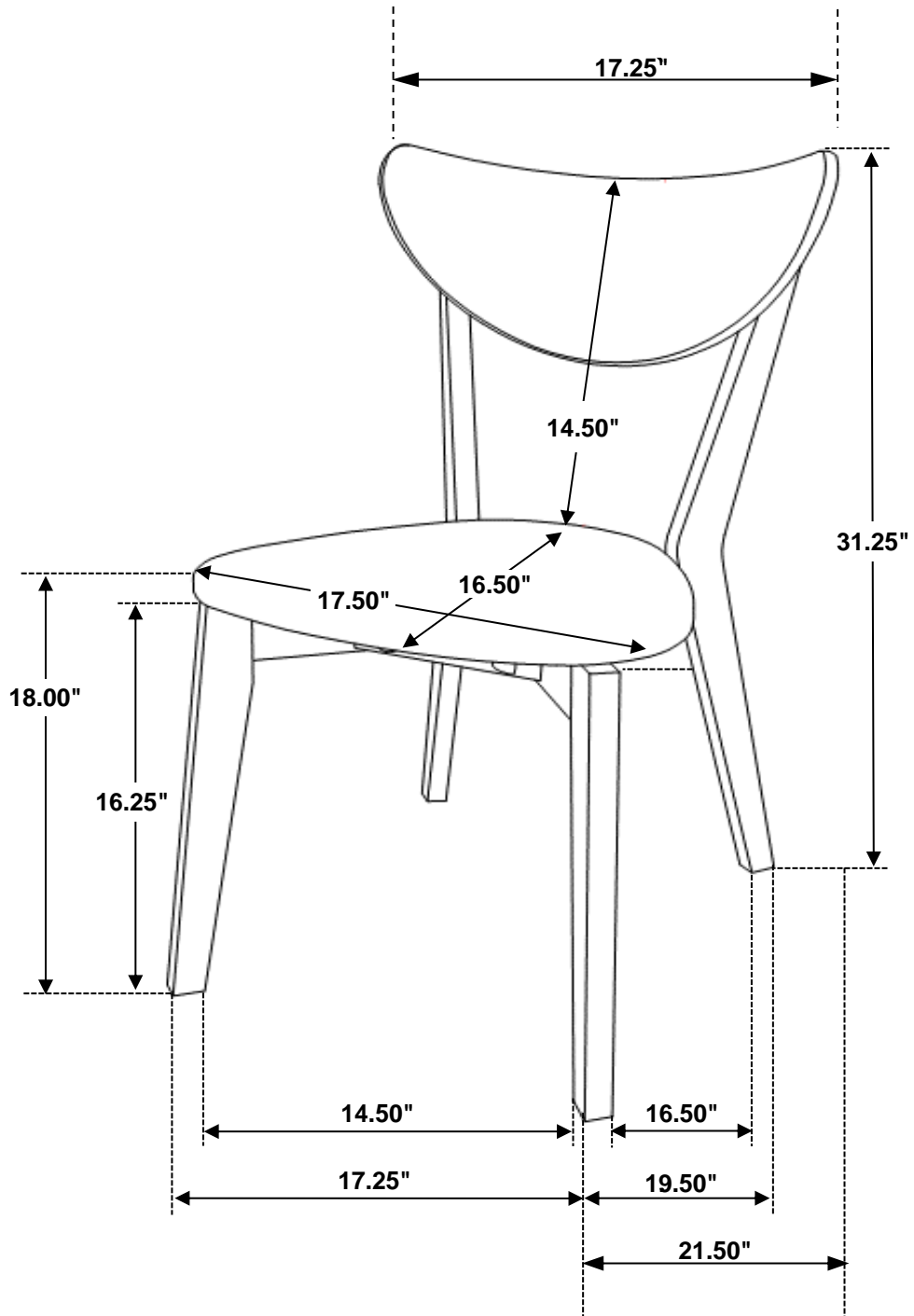

Note: Dimension tolerance $\pm 5\%$