

ASSEMBLY INSTRUCTIONS
COASTER FINE FURNITURE



Fine Furniture for every stage of life

109858(B1&B2)
Counter Height Table

ITEM: 109858(B1 & B2)



ASSEMBLY INSTRUCTIONS

ASSEMBLY TIPS:

1. Remove hardware from box and sort by size.
2. Please check to see that all hardware and parts are present prior to start of assembly.
3. Please follow attached instructions in the same sequence as numbered to assure fast & easy assembly.



WARNING!

1. Don't attempt to repair or modify parts that are broken or defective. Please contact the store immediately.
2. This product is for home use only and not intended for commercial establishments.



ASSEMBLY TIME

20 MINUTES

PARTS IDENTIFICATION

B1 (BOX 1)

A TOP



1PC

B2 (BOX 2)

B CENTER LEG FRAME

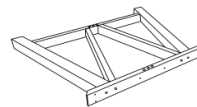

1PC

C SIDE LEG FRAME



2PCS

HARDWARE IDENTIFICATION

Z-B1 (BOX 1) - HARDWARE PACK IS LOCATED IN 109858 (B1)

1 ALLEN WRENCH
(M4 - BLK)



1PC

2 BOLT
(M6 x 50mm - RBW)



8PCS

3 HALF ROUND NUT
(BLK)



8PCS

4 PLASTIC DOWEL
(M8 x 30mm - BLK)



4PCS

5 WAFER HEAD SCREW
(M4 x 25mm - BLK)



12PCS

6 LEVELER
(20mm - BLK)



4PCS

ITEM: 109858(B1&B2)

ASSEMBLY INSTRUCTIONS

STEP 1

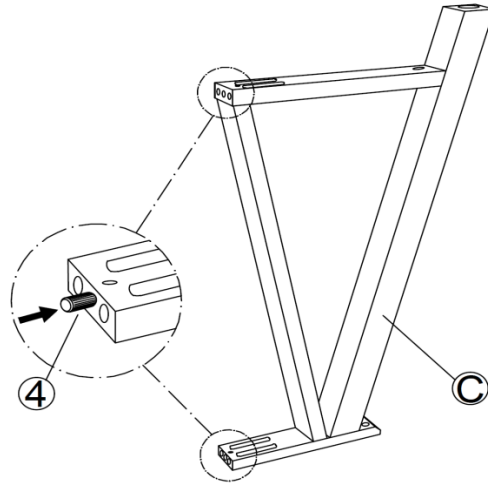

STEP 2

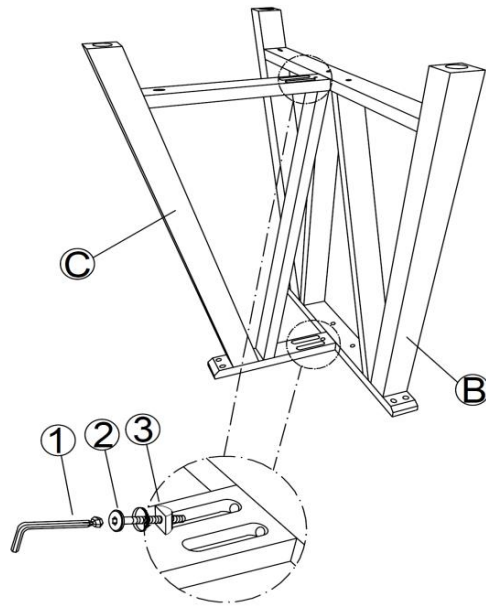

STEP 3

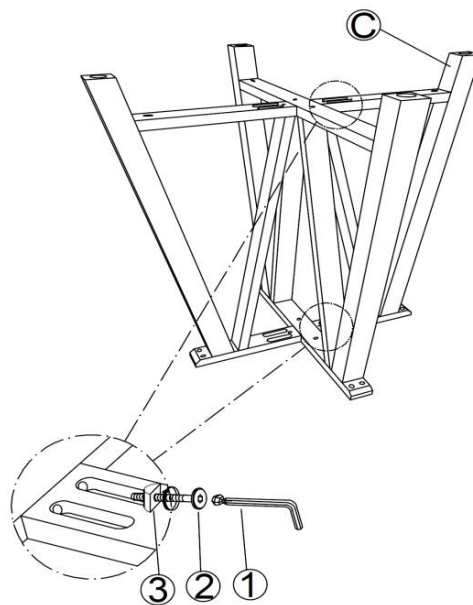

ITEM: **109858(B1&B2)**



ASSEMBLY INSTRUCTIONS

STEP 4

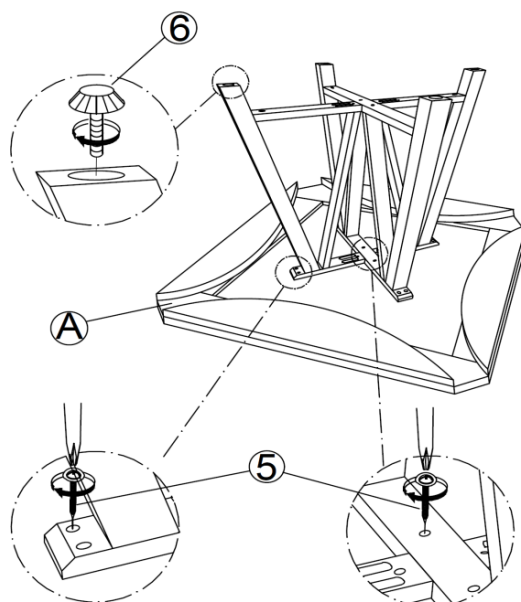

STEP 5

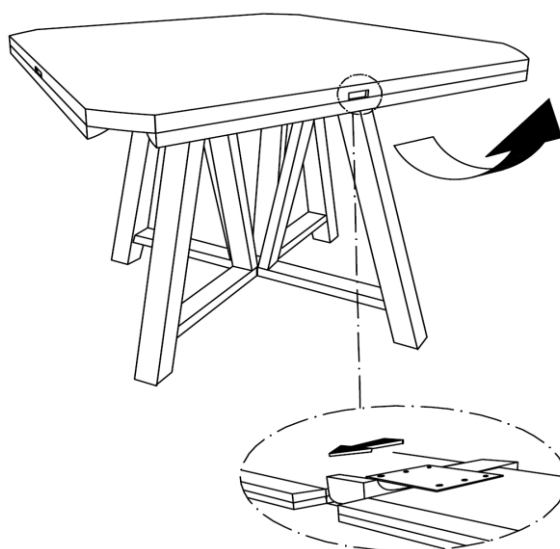

STEP 6
COMPLETE



ITEM: 109858(B1&B2)

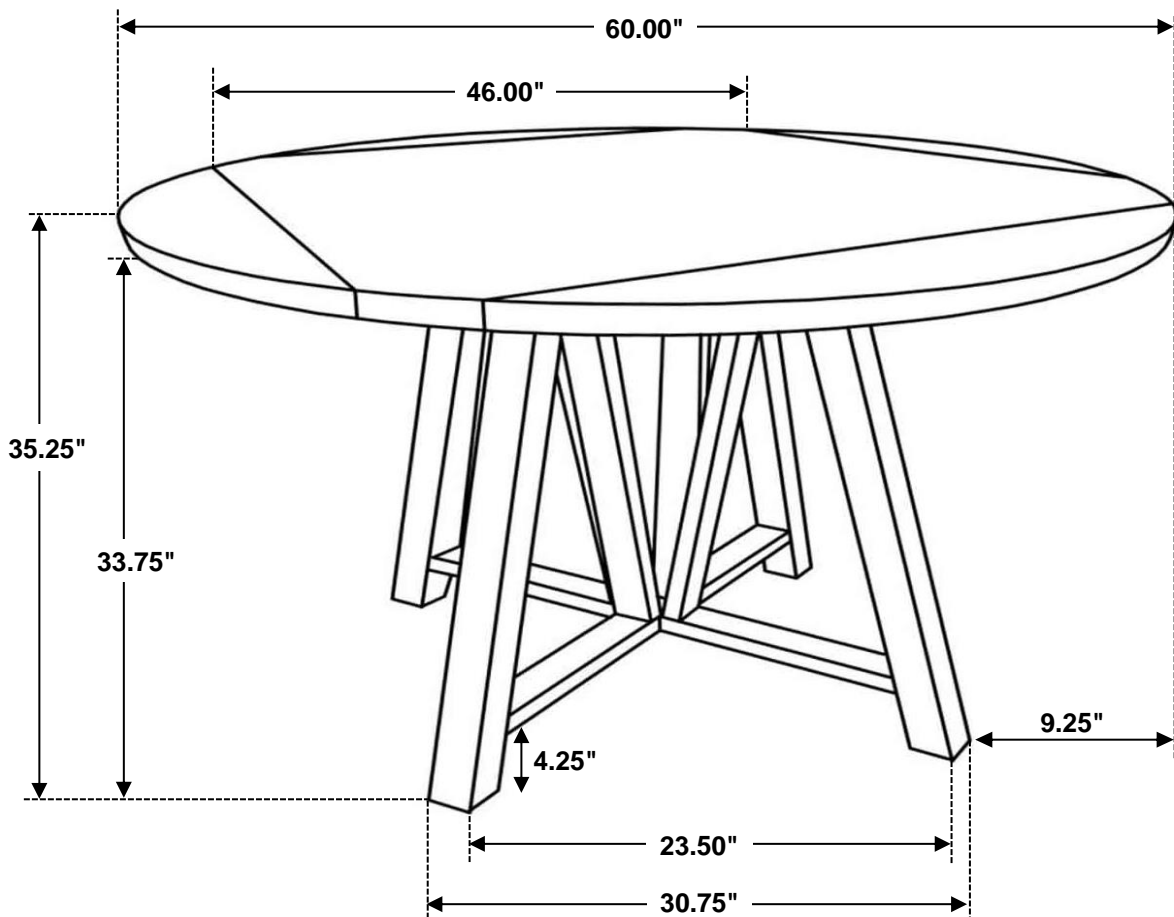

Note: Dimension tolerance $\pm 5\%$