



## ASSEMBLY INSTRUCTIONS COASTER FINE FURNITURE



*Fine Furniture for every stage of life*

**110035**

**Counter Height Chair**

REVISION 0 : 10/24/2020  
REVISION 1 : 01/02/2021

PAGE 1 OF 4

COASTERFURNITURE.COM

## ASSEMBLY INSTRUCTIONS

### ASSEMBLY TIPS :

1. Remove hardware from box and sort by size.
2. Please check to see that all hardware and parts are present prior to start of assembly.
3. Please follow attached instructions in the same sequence as numbered to assure fast & easy assembly.



### WARNING!

1. Don't attempt to repair or modify parts that are broken or defective. Please contact the store immediately.
2. This product is for home use only and not intended for commercial establishments.

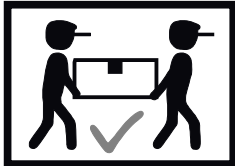

ASSEMBLY TIME

15 MINUTES

## PARTS IDENTIFICATION

A	SEAT AND BACK		1PC
B	LEFT FRONT LEG		1PC
C	RIGHT FRONT LEG		1PC
D	LEFT BACK LEG		1PC
E	RIGHT BACK LEG		1PC
F	FRONT STRETCHER		1PC
G	RIGHT SIDE STRETCHER		1PC
H	LEFT SIDE STRETCHER		1PC
I	BACK STRETCHER		1PC
J	LOOSE SEAT CUSHION		1PC

## HARDWARE IDENTIFICATION

1	BOLT (Ø5/16" x 1-3/16" - BLK)		8PCS
2	LOCK WASHER (Ø5/16" - RBW)		8PCS
3	FLAT WASHER (Ø5/16" - RBW)		8PCS
4	PAN HEAD SCREW (Ø8 x 50MM - RBW)		8PCS
5	ALLEN WRENCH (6MM - BLK)		1PC

### NOTE:

Quantities shown are for one chair.

Phillips head screw driver is required in the assembly process; however, manufacturer does not provide this item.

ITEM : **110035**

**ASSEMBLY INSTRUCTIONS**

**STEP 1**

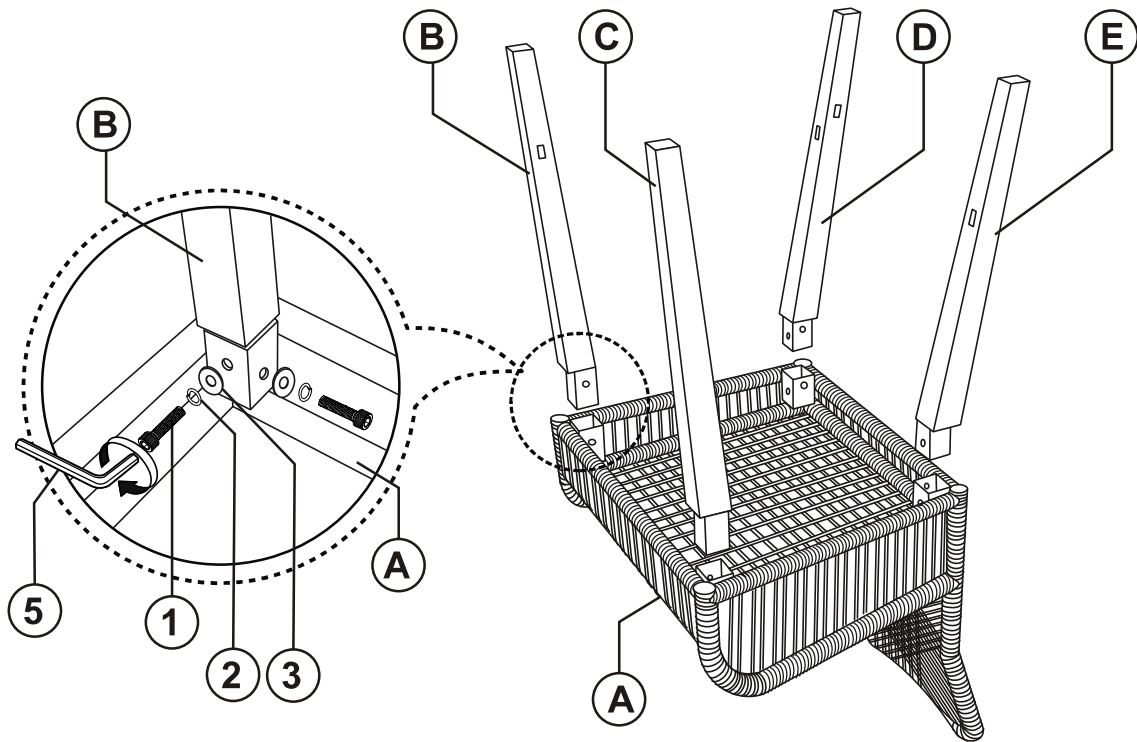

**STEP 2**

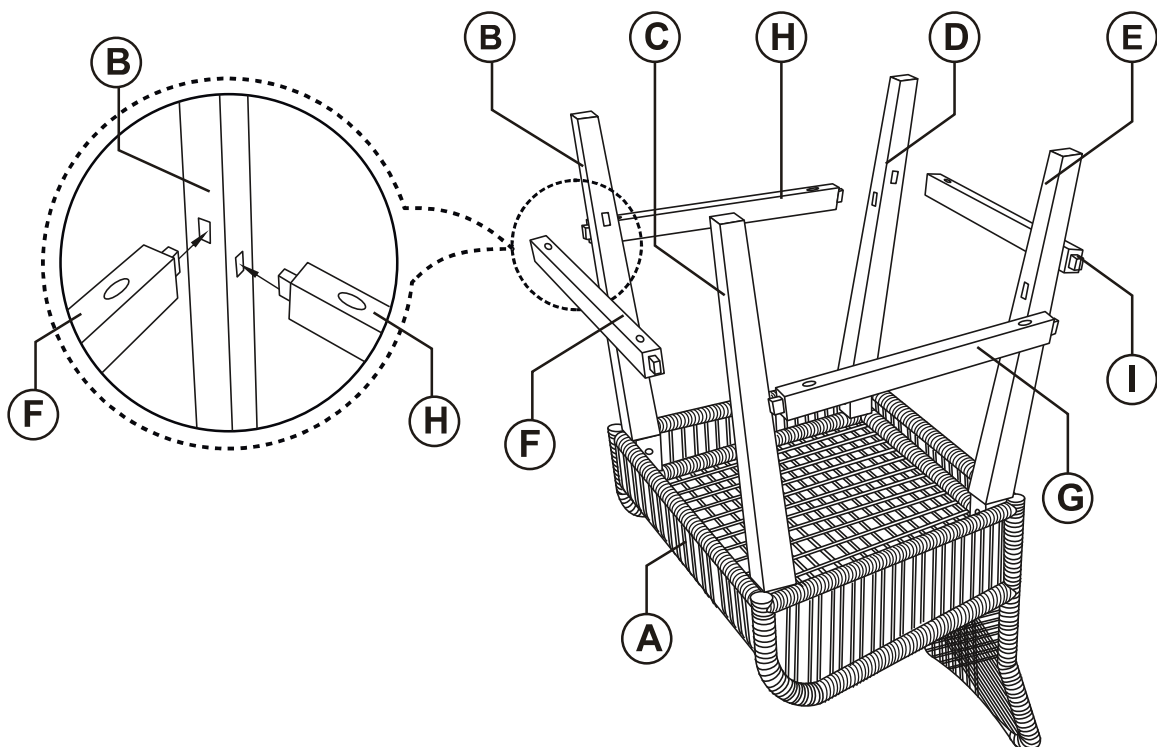

ITEM : **110035**

**ASSEMBLY INSTRUCTIONS**

**STEP 3**

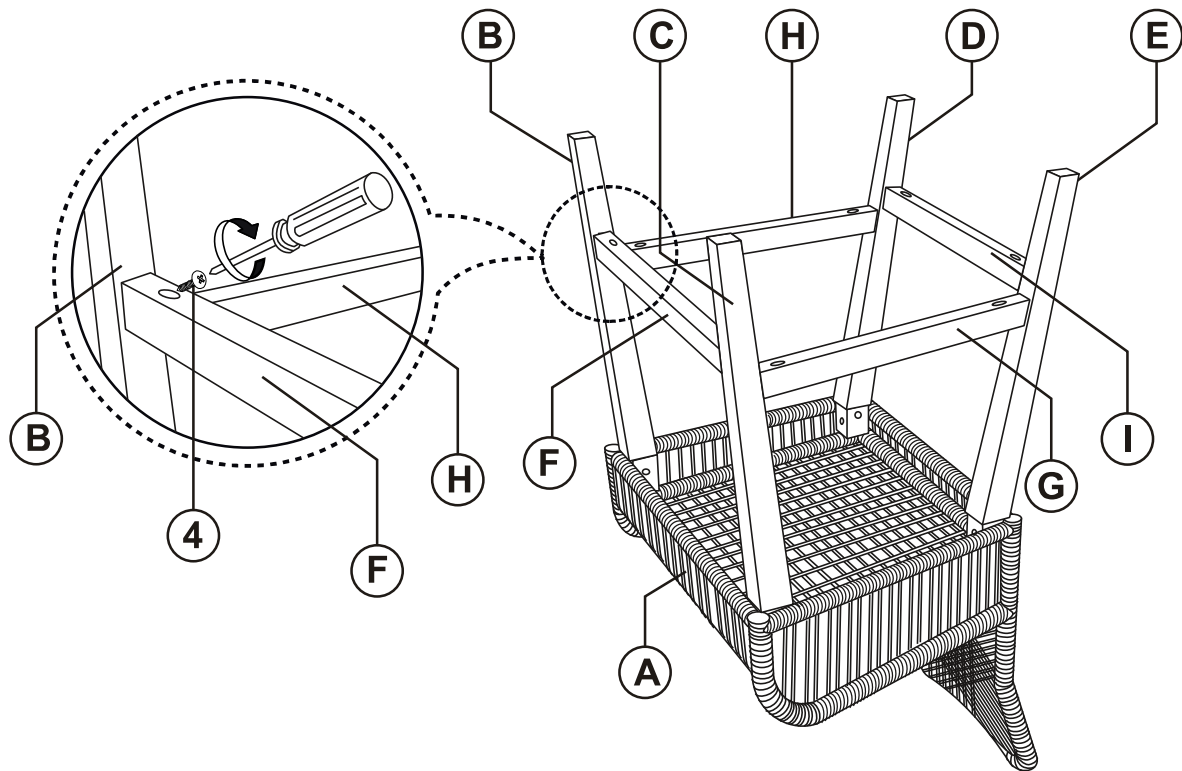

**STEP 4**

**COMPLETE**

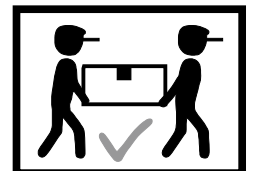
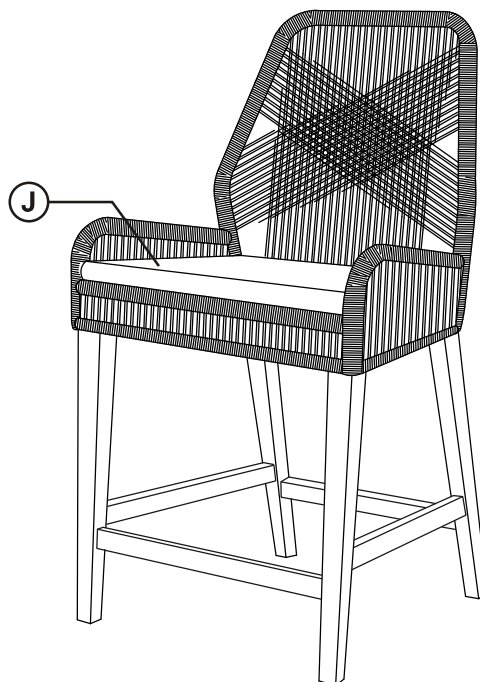

ITEM : 110035

**COASTER**  
FINE FURNITURE

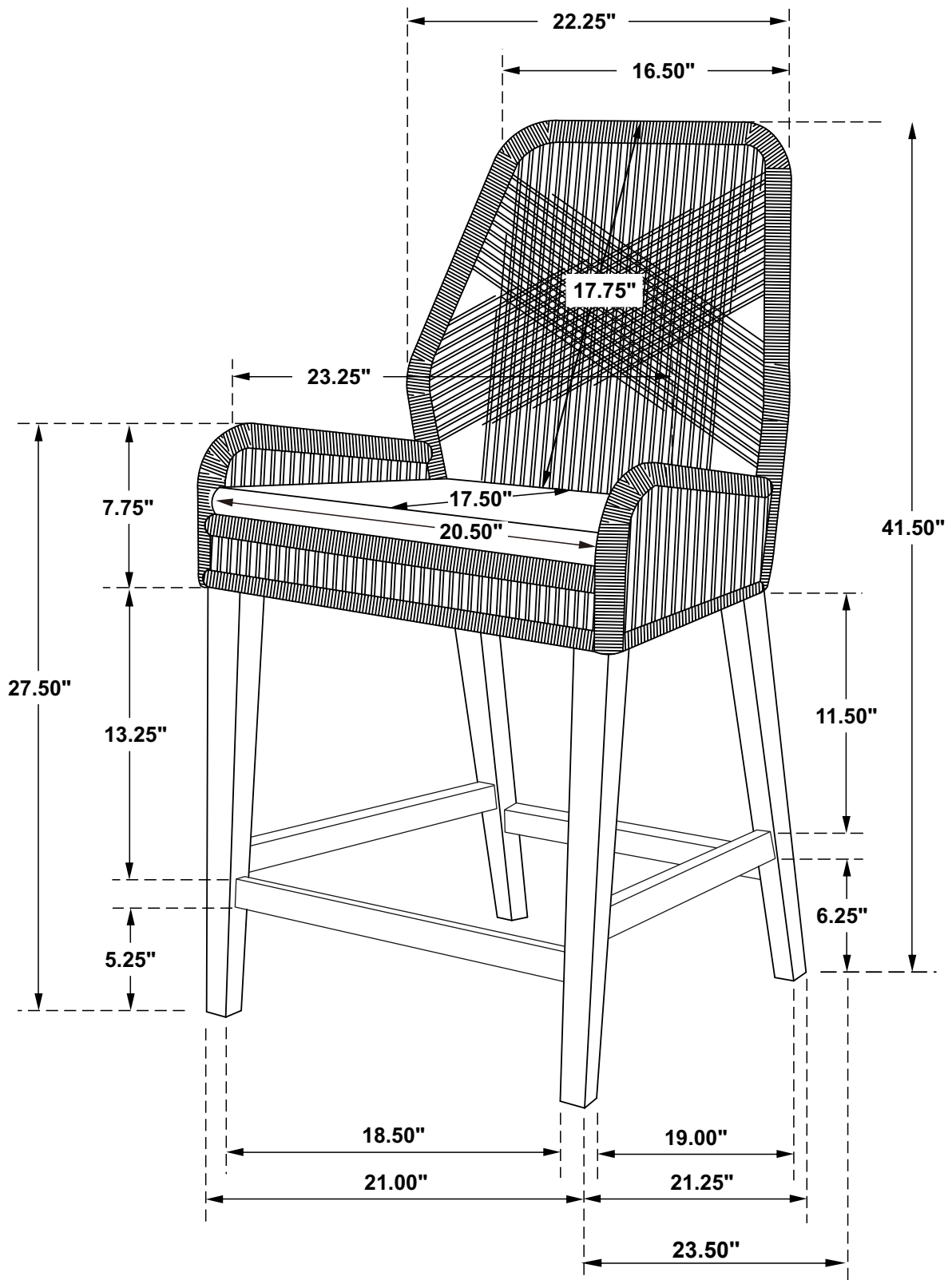

Note : Dimension tolerance  $\pm 5\%$