

ASSEMBLY INSTRUCTIONS
COASTER FINE FURNITURE



Fine Furniture for every stage of life

122249
Counter Height Chair

ITEM:122249



ASSEMBLY INSTRUCTIONS

ASSEMBLY TIPS:

1. Remove hardware from box and sort by size.
2. Please check to see that all hardware and parts are present prior to start of assembly.
3. Please follow attached instructions in the same sequence as numbered to assure fast & easy assembly.



WARNING!







1. Don't attempt to repair or modify parts that are broken or defective. Please contact the store immediately.
2. This product is for home use only and not intended for commercial establishments.

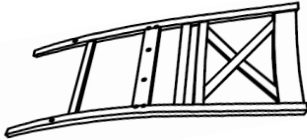
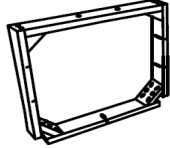

ASSEMBLY TIME

15 MINUTES

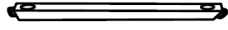
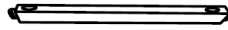
PARTS IDENTIFICATION

A	BACK FRAME		1PC
B	SEAT FRAME		1PC
C	SEAT CUSHION		1PC
D	LEFT FORNT LEG		1PC
E	RIGHT FRONT LEG		1PC
F	LEFT SIDE STRETCHER		1PC
G	RIGHT SIDE STRETCHER		1PC
H	FRONT STRETCHER		1PC

NOTE:

Quantities shown are for one chair.

Phillips head screw driver is required in the assembly process; however, manufacturer does not provide this item.

ITEM:122249



ASSEMBLY INSTRUCTIONS

ASSEMBLY TIPS:

1. Remove hardware from box and sort by size.
2. Please check to see that all hardware and parts are present prior to start of assembly.
3. Please follow attached instructions in the same sequence as numbered to assure fast & easy assembly.



WARNING!









1. Don't attempt to repair or modify parts that are broken or defective. Please contact the store immediately.
2. This product is for home use only and not intended for commercial establishments.



ASSEMBLY TIME

15 MINUTES

HARDWARE IDENTIFICATION

1	ALLEN WRENCH (M4 - BLK)		1PC
2	SHORT BOLT (M6 x 40mm - RBW)		2PCS
3	MEDIUM BOLT (M6 x 60mm - RBW)		4PCS
4	LONG BOLT (M6 x 70mm - RBW)		4PCS
5	LOCK WASHER (M6 - RBW)		10PCS
6	FLAT WASHER (M6 - RBW)		10PCS
7	SHORT FLAT HEAD SCREW (M4 x 25mm - RBW)		5PCS
8	LONG FLAT HEAD SCREW (M4 x 38mm - RBW)		6PCS

NOTE:

Quantities shown are for one chair.

Phillips head screw driver is required in the assembly process; however, manufacturer does not provide this item.

ITEM: **122249**

ASSEMBLY INSTRUCTIONS
STEP 1

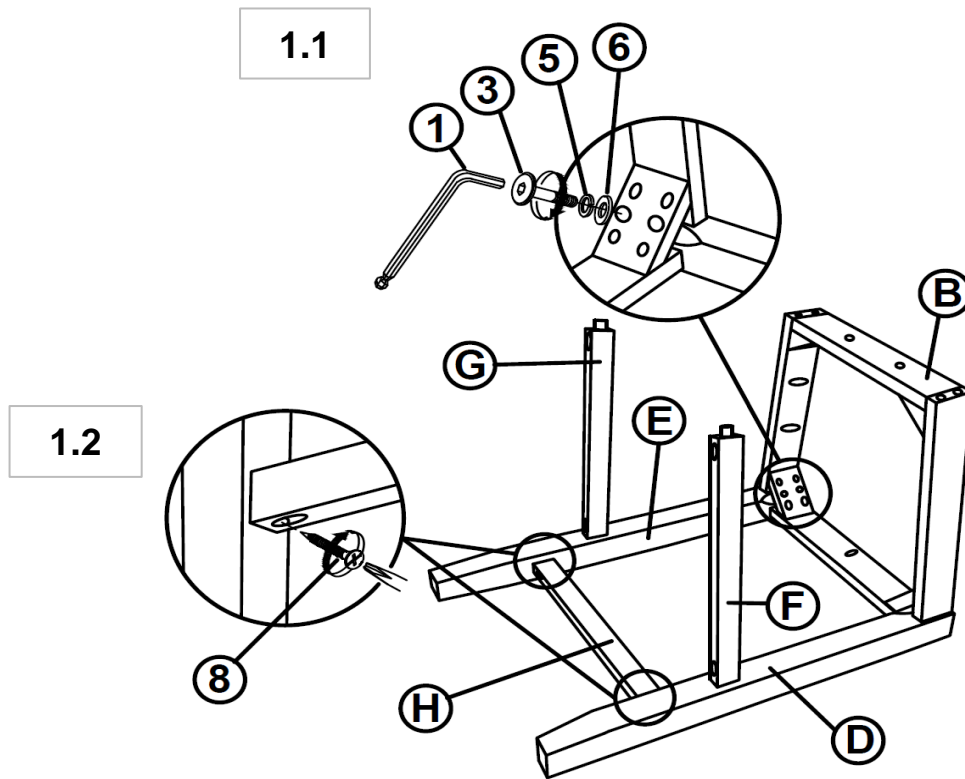

STEP 2

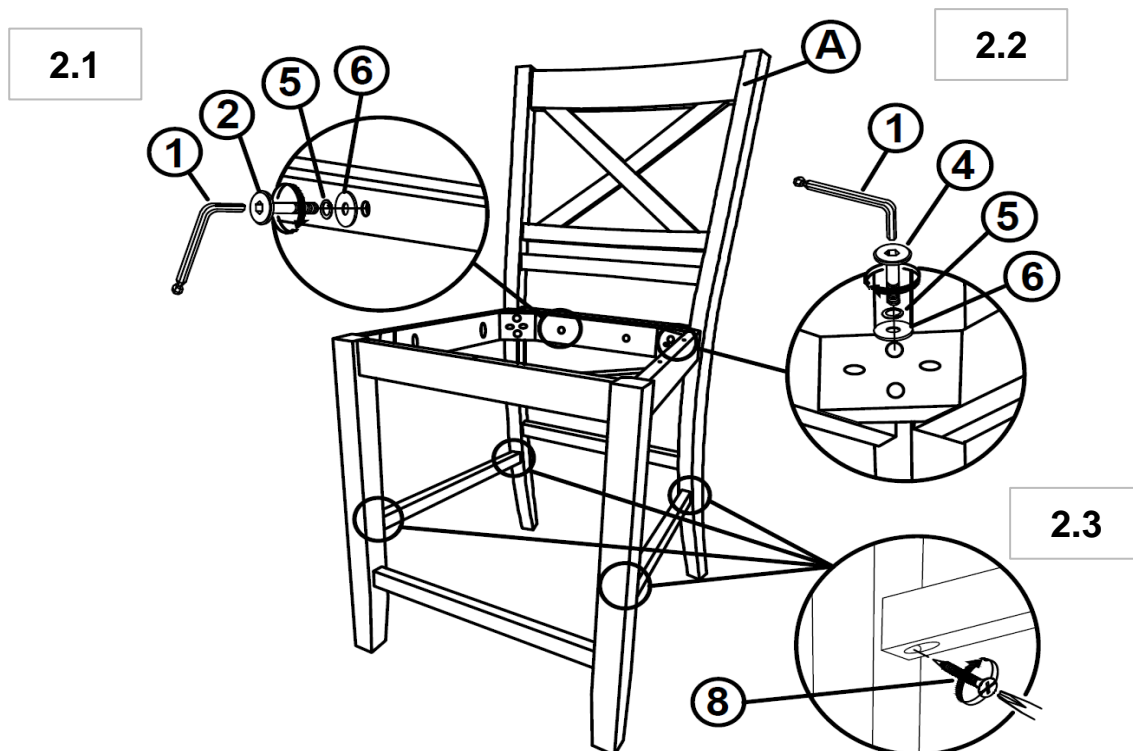

ITEM: **122249**

ASSEMBLY INSTRUCTIONS

STEP 3

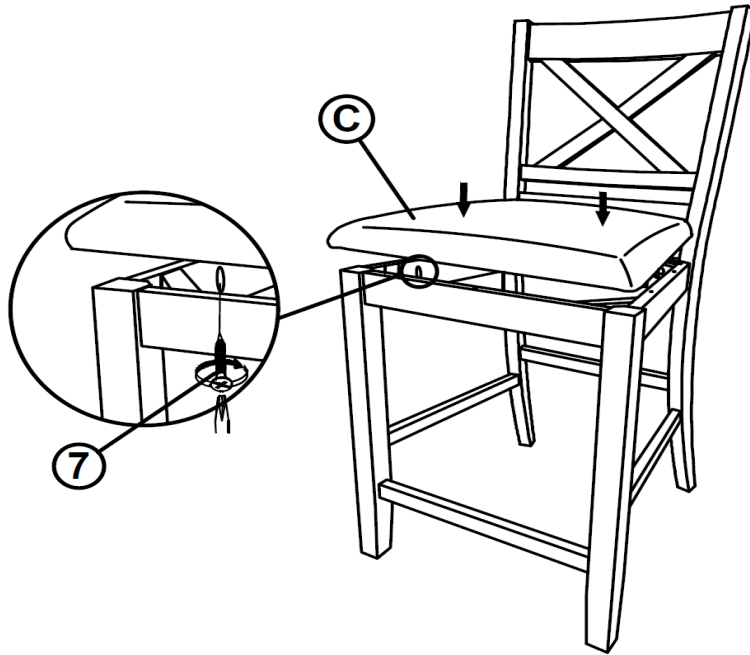

STEP 4
COMPLETE

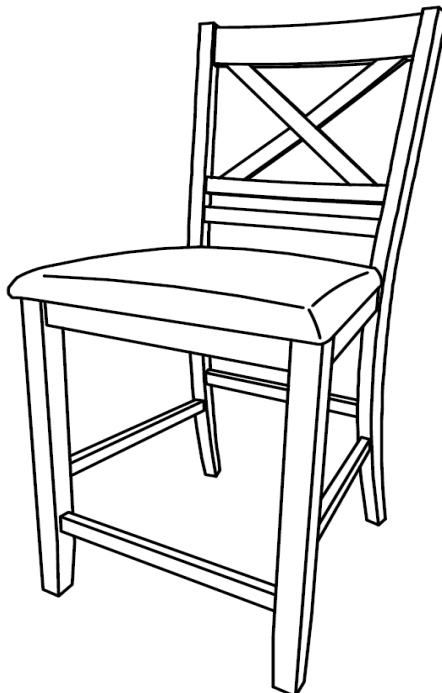

ITEM: 122249

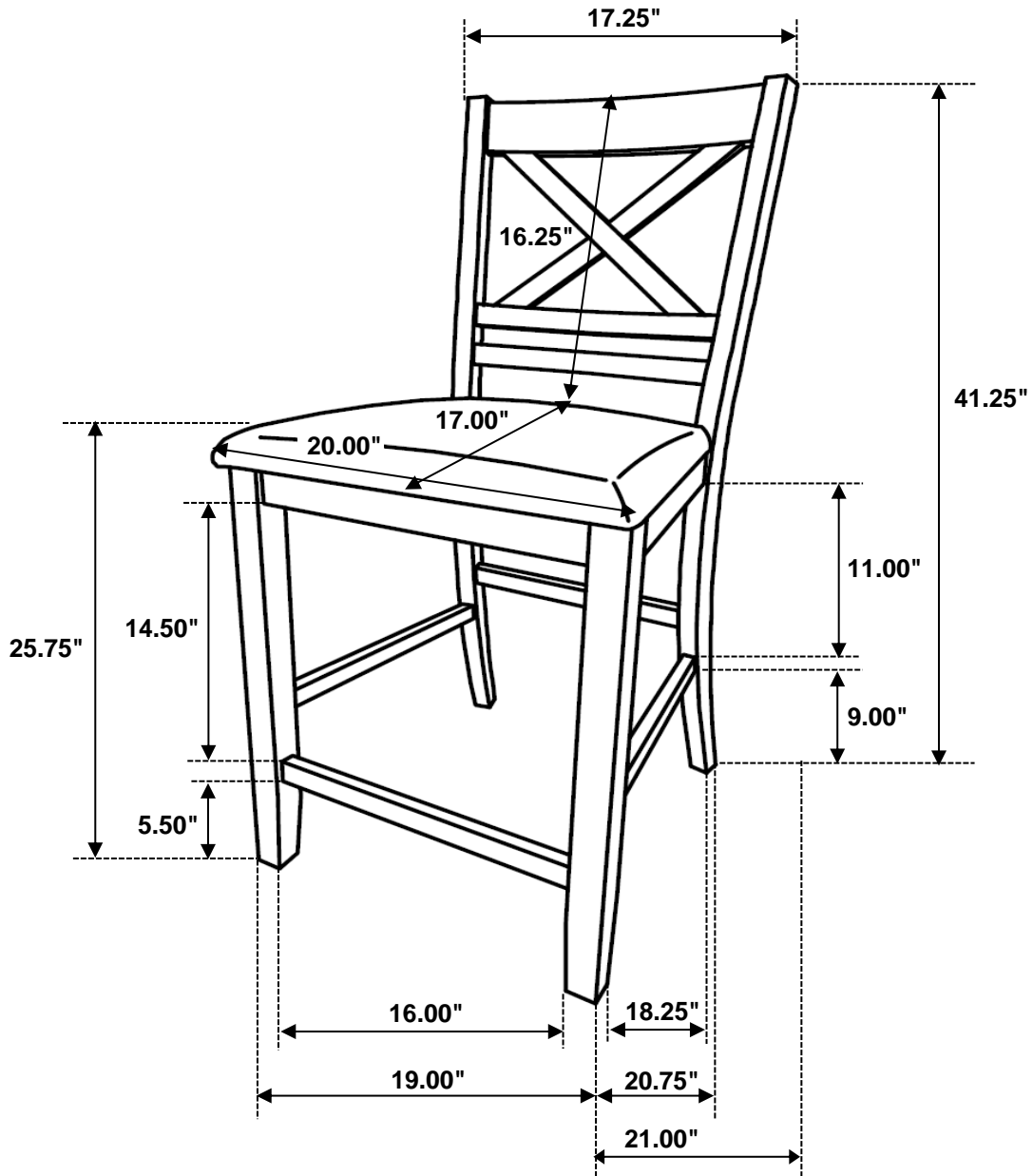

Note: Dimension tolerance $\pm 5\%$