



ASSEMBLY INSTRUCTIONS
COASTER FINE FURNITURE



Fine Furniture for every stage of life

183405
COUNTER HEIGHT STOOL

REVISION 0 : 06/23/2020
REVISION 1 : 11/20/2023

ITEM: 183405



ASSEMBLY INSTRUCTIONS

ASSEMBLY TIPS:

1. Remove hardware from box and sort by size.
2. Please check to see that all hardware and parts are present prior to start of assembly.
3. Please follow attached instructions in the same sequence as numbered to assure fast & easy assembly.



WARNING!

1. Don't attempt to repair or modify parts that are broken or defective. Please contact the store immediately.
2. This product is for home use only and not intended for commercial establishments.



ASSEMBLY TIME 35 MINUTES

PARTS IDENTIFICATION

A SEAT CUSHION

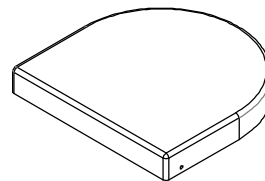

1PC

B ACRYLIC BACK FRAME

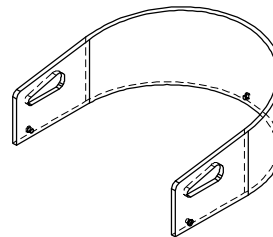

1PC

C STOOL BASE

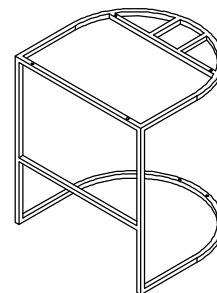

1PC

D CROSSBAR

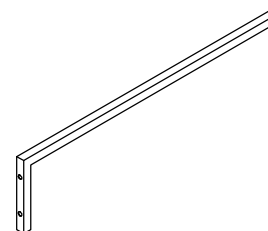







2PCS

ITEM:183405

ASSEMBLY INSTRUCTIONS

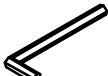

z HARDWARE IDENTIFICATION

1	SHORT BOLT (1/4" x 21mm SR)		3PCS
2	MEDIUM BOLT (1/4" x 28mm SR)		10PCS
3	NUT (1/4")		3PCS
4	LEVELER (1/4" x 12mm BLK)		5PCS
5	CAP (16 x 16mm)		2PCS
6	WASHER (ϕ 16mm)		2PCS
7	PLASTIC WASHER (ϕ 19mm)		3PCS
8	ALLEN WRENCH (4mm)		1PC

NOTE:QUANTITIES SHOWN ARE FOR ONE STOOL

ITEM: 183405

ASSEMBLY INSTRUCTIONS

STEP 1

Do not tighten until each step is completed or instructed.

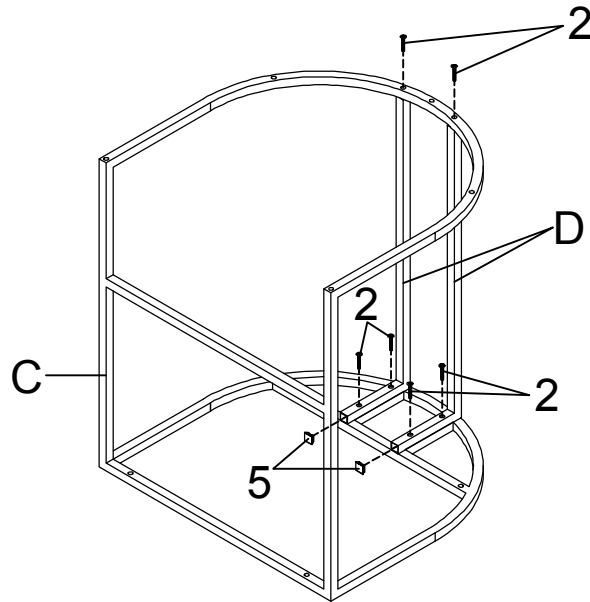

STEP 2

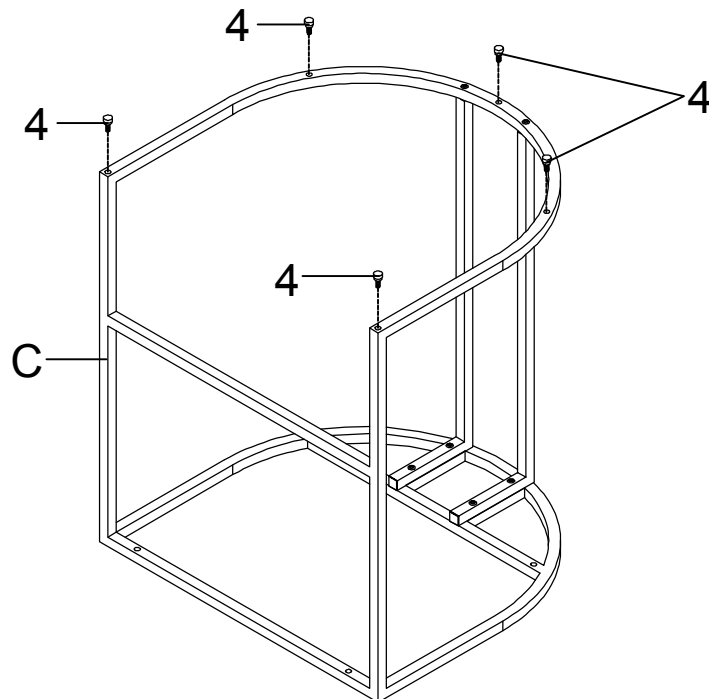

ITEM: 183405

ASSEMBLY INSTRUCTIONS

STEP 3

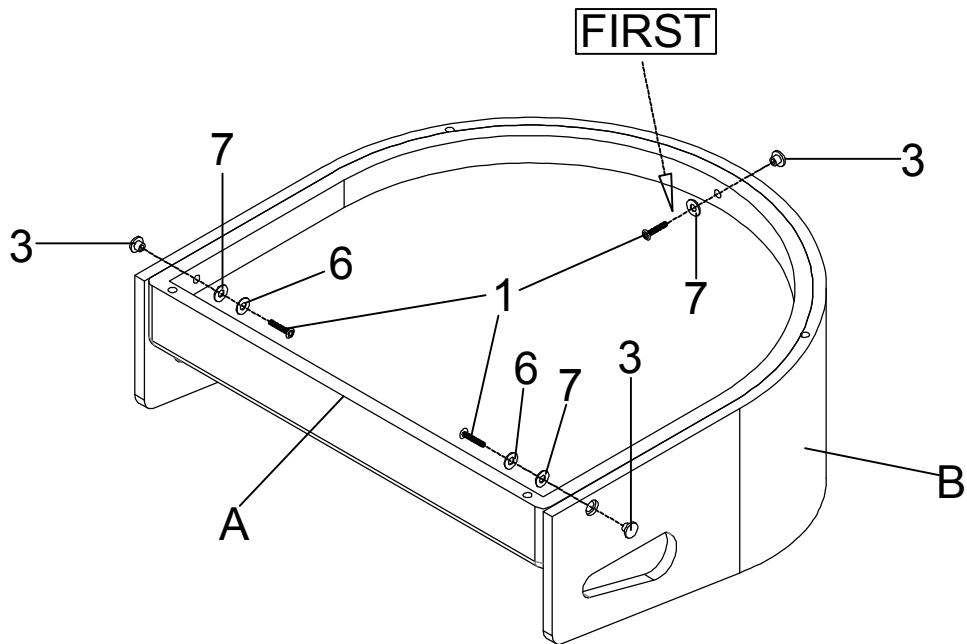

STEP 4

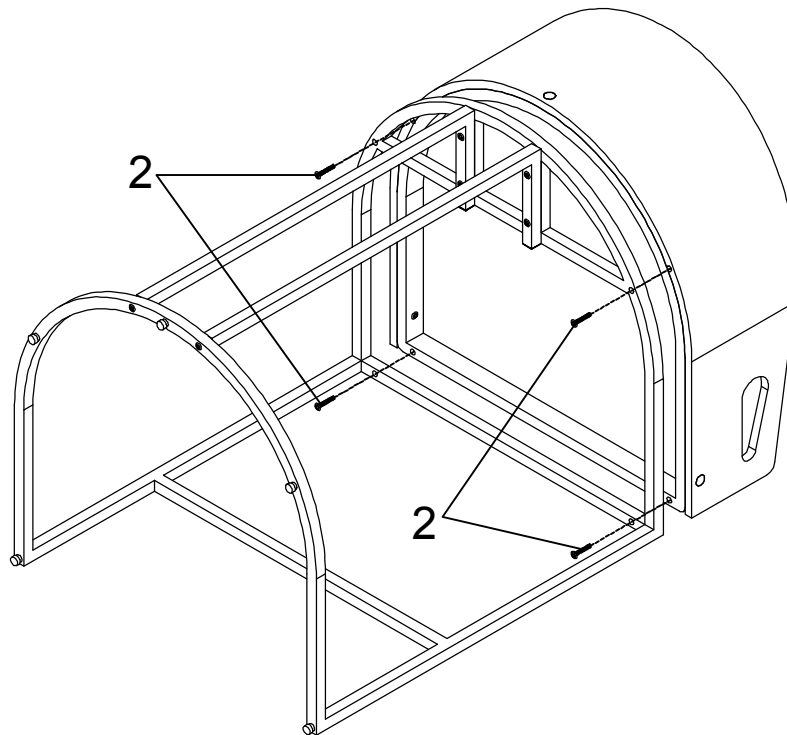

How to clean Acrylic product:
Using a dry soft microfiber cloth, lightly brush off any dust.
For additional care, dampen the cloth with warm water.
For deepest cleaning, use an Acrylic cleaner.

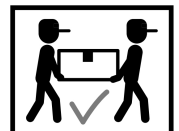

ITEM:183405 ASSEMBLY INSTRUCTIONS



Product Size : 546 X 489 X 826 H (MM)

Product Size : 21.5" X 19.25" X 32.5"

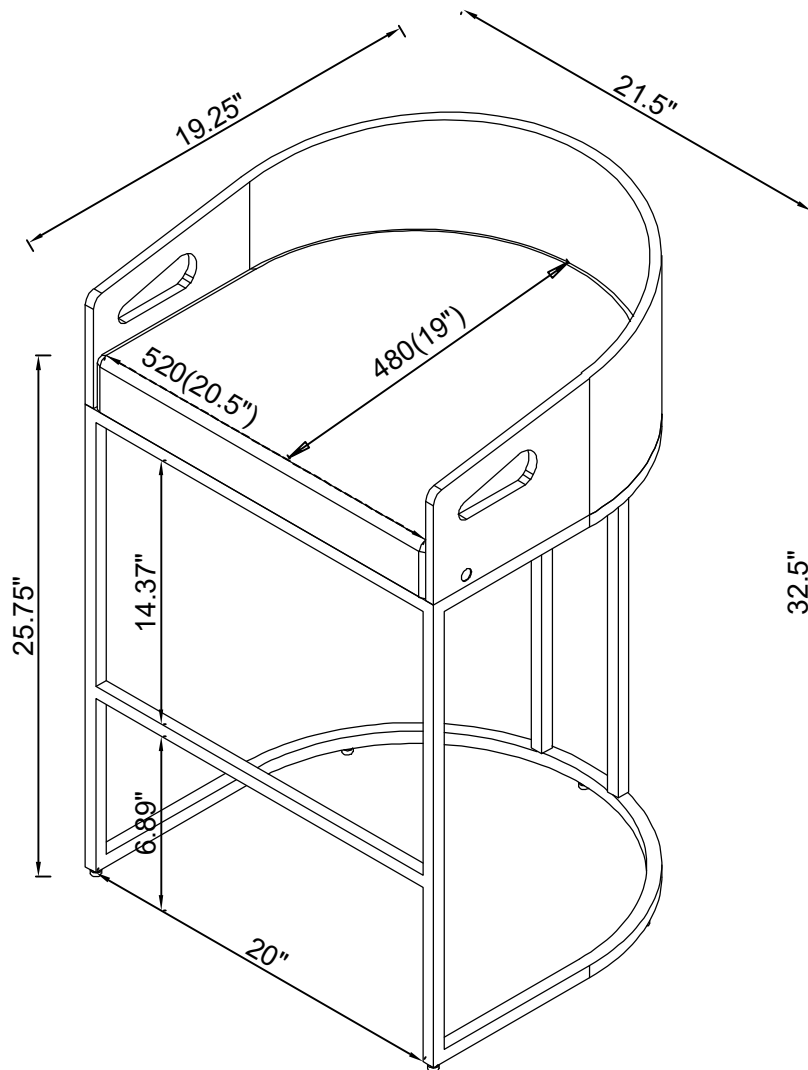

Note : Dimension tolerance $\pm 5\%$