

ASSEMBLY INSTRUCTIONS
COASTER FINE FURNITURE

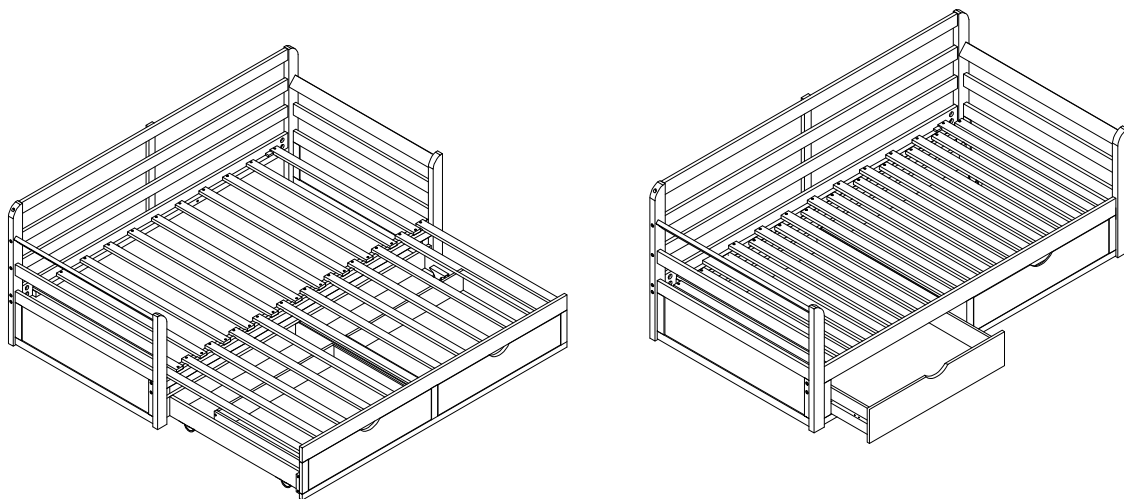

Fine Furniture for every stage of life

305706 (B1&B2)
Day Bed

ITEM: 305706 (B1&B2)



ASSEMBLY INSTRUCTIONS

ASSEMBLY TIPS:

1. Remove hardware from box and sort by size.
2. Please check to see that all hardware and parts are present prior to start of assembly.
3. Please follow attached instructions in the same sequence as numbered to assure fast & easy assembly.



WARNING!

1. Don't attempt to repair or modify parts that are broken or defective. Please contact the store immediately.
2. This product is for home use only and not intended for commercial establishments.

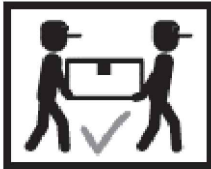



ASSEMBLY TIME





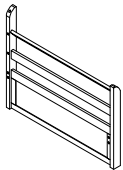
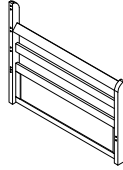





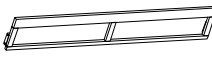

30 MINUTES

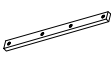
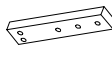
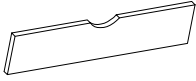
PARTS IDENTIFICATION

B1 (BOX 1)

<p>A LEFT SIDE FRAME</p>  <p>1PC</p>	<p>C RIGHT SIDE FRAME</p>  <p>1PC</p>
<p>B GREY BED SLAT</p>  <p>2PCS</p>	<p>D BED SLAT</p>  <p>21PCS</p>

B2 (BOX 2)

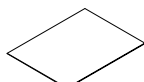
<p>E BACK RAIL</p>  <p>1PC</p>	<p>N TRUNDLE FRONT PANEL</p>  <p>1PC</p>
<p>F FRONT RAIL</p>  <p>1PC</p>	<p>O TRUNDLE LOWER BACK PANEL</p>  <p>1PC</p>
<p>G GUARDRAIL</p>  <p>3PCS</p>	<p>P TRUNDLE UPPER BACK PANEL</p>  <p>1PC</p>
<p>H GUARDRAIL SUPPORT</p>  <p>1PC</p>	<p>Q TRUNDLE BACK RAIL SUPPORT</p>  <p>2PCS</p>
<p>I DRAWER FRONT PANEL</p>  <p>2PCS</p>	<p>R TRUNDLE LEFT SIDE PANEL WITH CASTER</p>  <p>1PC</p>
<p>J DRAWER BACK PANEL</p>  <p>2PCS</p>	<p>S TRUNDLE RIGHT SIDE PANEL WITH CASTER</p>  <p>1PC</p>
<p>K DRAWER LEFT PANEL</p>  <p>2PCS</p>	<p>T TRUNDLE MIDDLE PANEL (WITH "T" LABEL)</p>  <p>1PC</p>
<p>L DRAWER RIGHT PANEL</p>  <p>2PCS</p>	<p>U TRUNDLE MIDDLE PANEL (WITH "U" LABEL)</p>  <p>1PC</p>
<p>M DRAWER BOTTOM PANEL</p>  <p>2PCS</p>	

NOTE:

Phillips head screw driver is required in the assembly process; however, manufacturer does not provide this item.

ITEM: 305706 (B1&B2)

ASSEMBLY INSTRUCTIONS



ASSEMBLY TIPS:

1. Remove hardware from box and sort by size.
2. Please check to see that all hardware and parts are present prior to start of assembly.
3. Please follow attached instructions in the same sequence as numbered to assure fast & easy assembly.











WARNING!

1. Don't attempt to repair or modify parts that are broken or defective. Please contact the store immediately.
2. This product is for home use only and not intended for commercial establishments.

HARDWARE IDENTIFICATION

Z-B2 (BOX2) - HARDWARE PACK IS LOCATED IN 305706 (B2)

1	BOLT 4 (1/4 x 110mm Φ 14 - BLK)		10PCS	6	BOLT 3 (1/4 x 80mm Φ 14 - BLK)		4PCS
2	BARREL NUT (1/4 x 12mm - BLK)		18PCS	7	SHORT WOOD DOWEL (10 x 40mm)		18PCS
3	BOLT 2 (1/4 x 60mm Φ 14 - BLK)		4PCS	8	LONG WOOD DOWEL (10 x 50mm)		2PCS
4	BOLT 1 (1/4 x 30mm Φ 14 - BLK)		14PCS	9	ALLEN WRENCH (4 x 58MM - BLK)		1PC
5	FLAT HEAD SCREW (4 x 35mm - BLK)		64PCS				

NOTE:

Phillips head screw driver is required in the assembly process; however, manufacturer does not provide this item.

ITEM: **305706 (B1&B2)**
ASSEMBLY INSTRUCTIONS

STEP 1

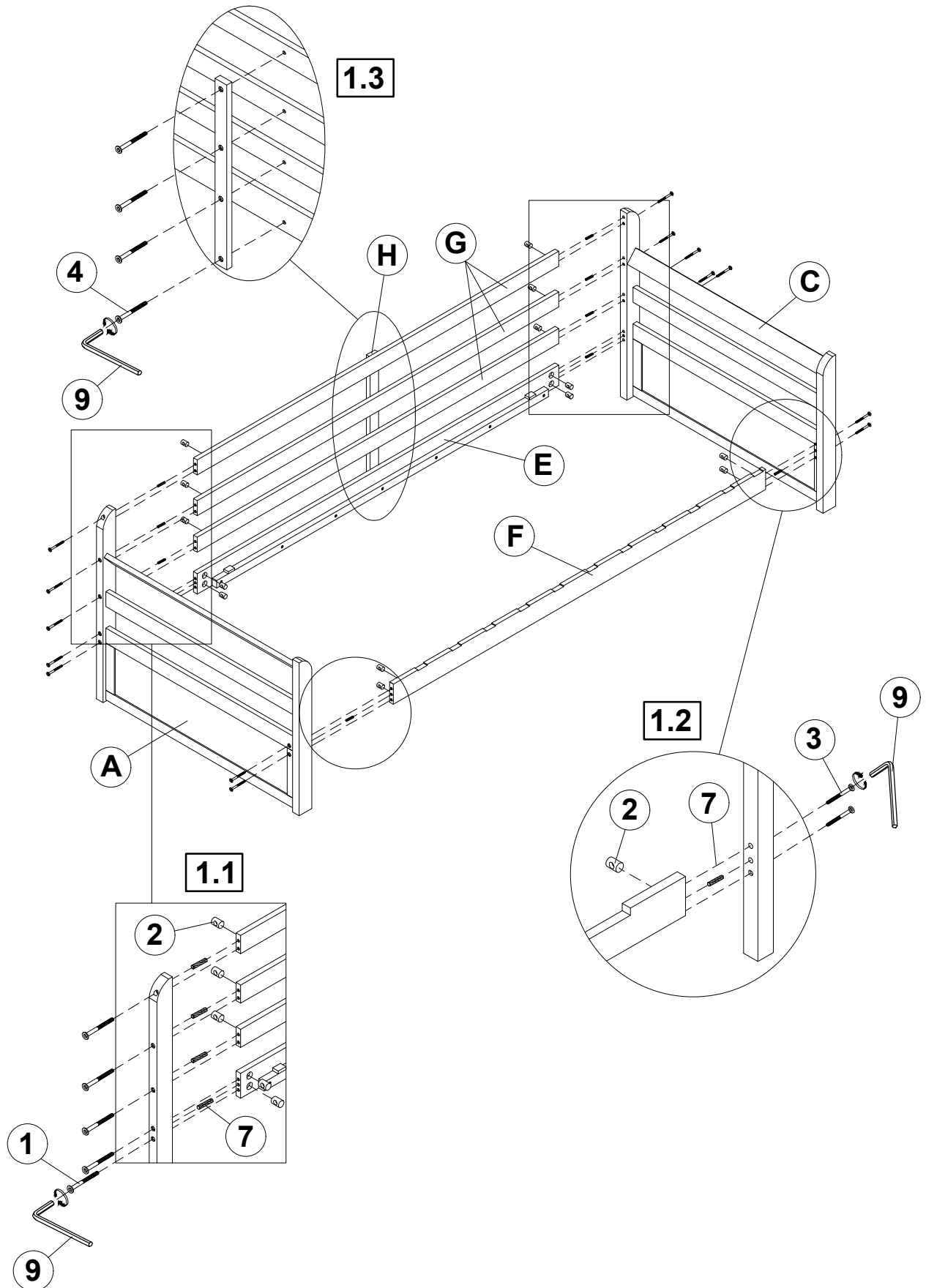

ITEM: **305706 (B1&B2)**
ASSEMBLY INSTRUCTIONS

STEP 2

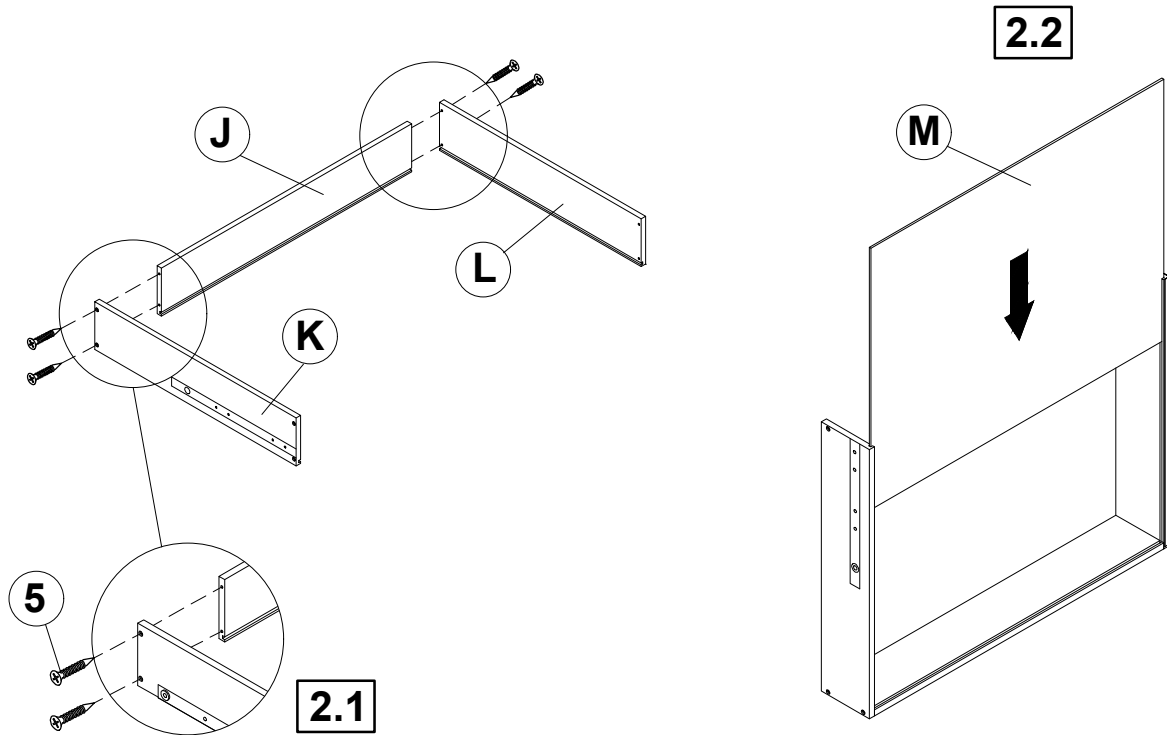

STEP 3

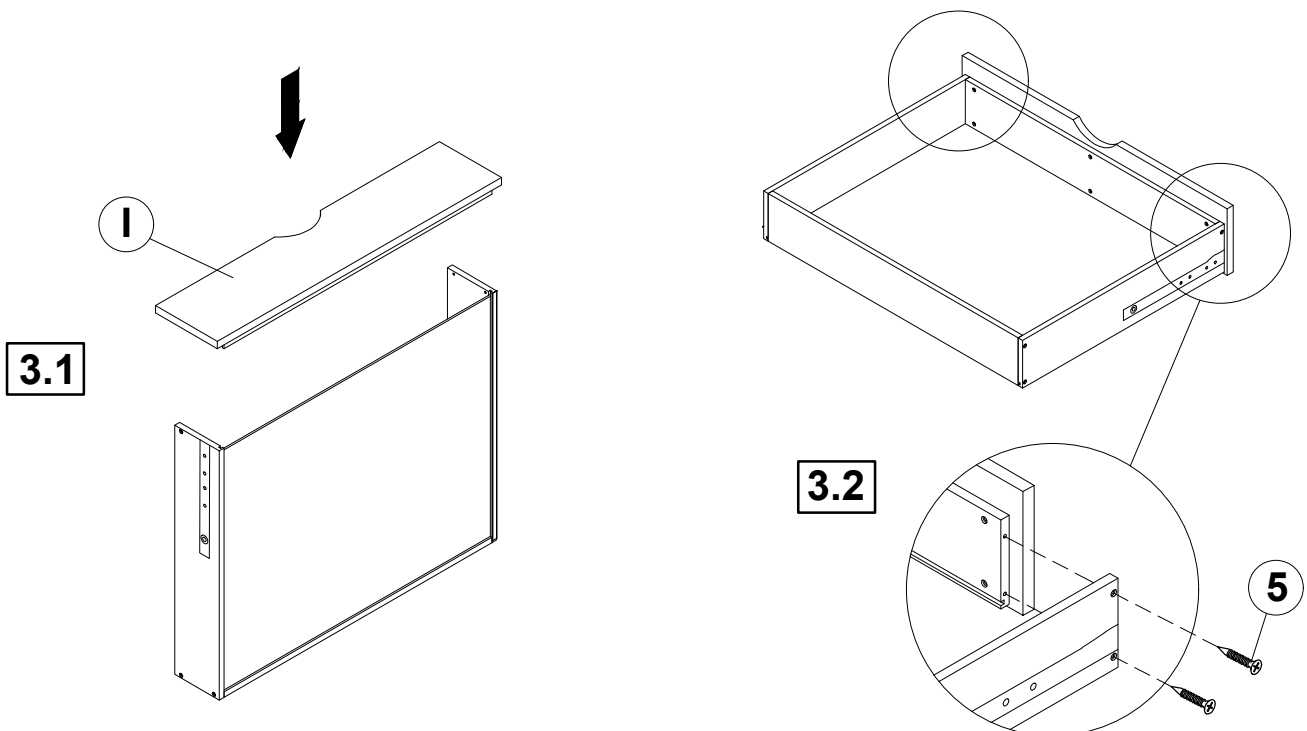

ITEM: 305706 (B1&B2)

ASSEMBLY INSTRUCTIONS

STEP 4

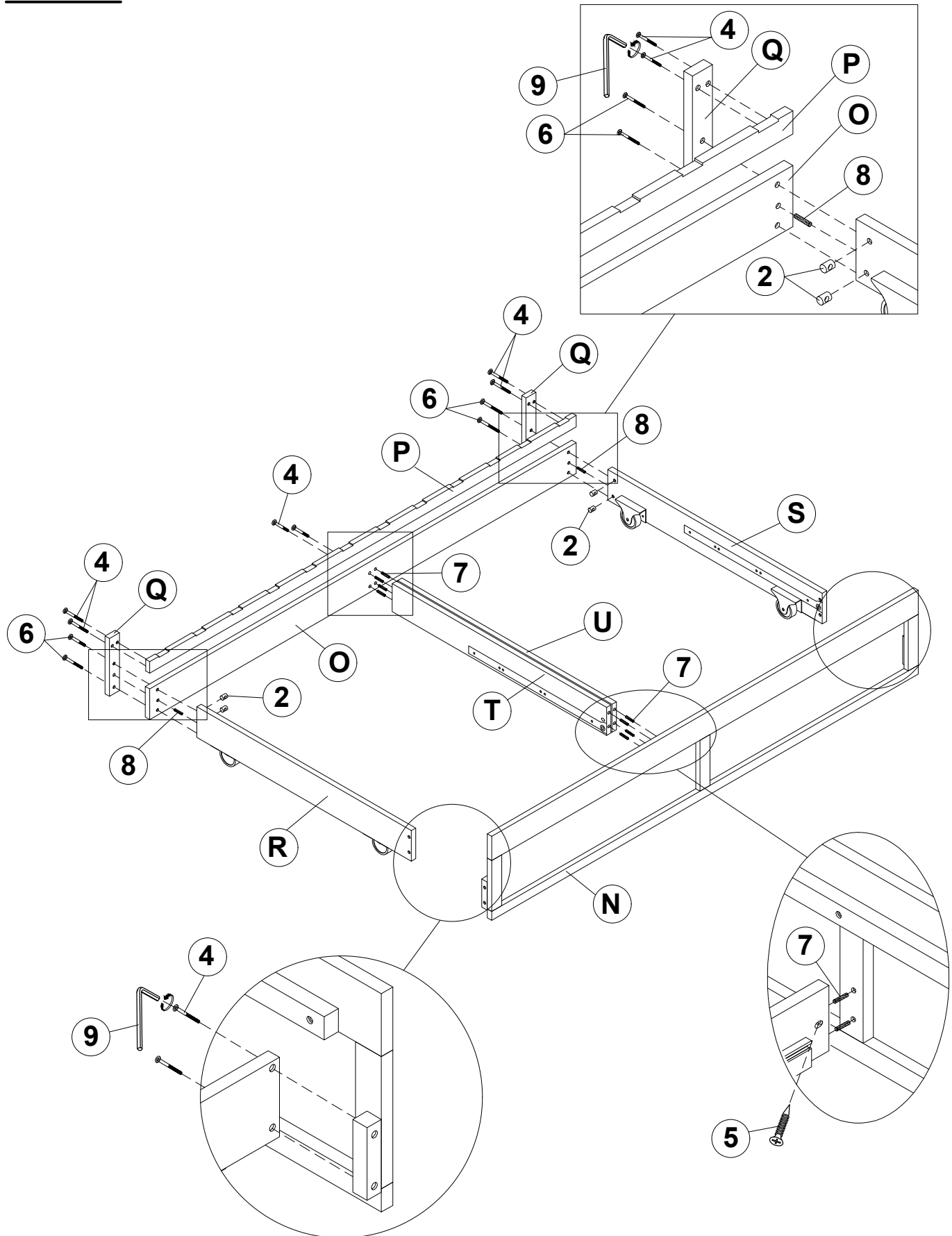

ITEM: **305706 (B1&B2)**
ASSEMBLY INSTRUCTIONS

STEP 5

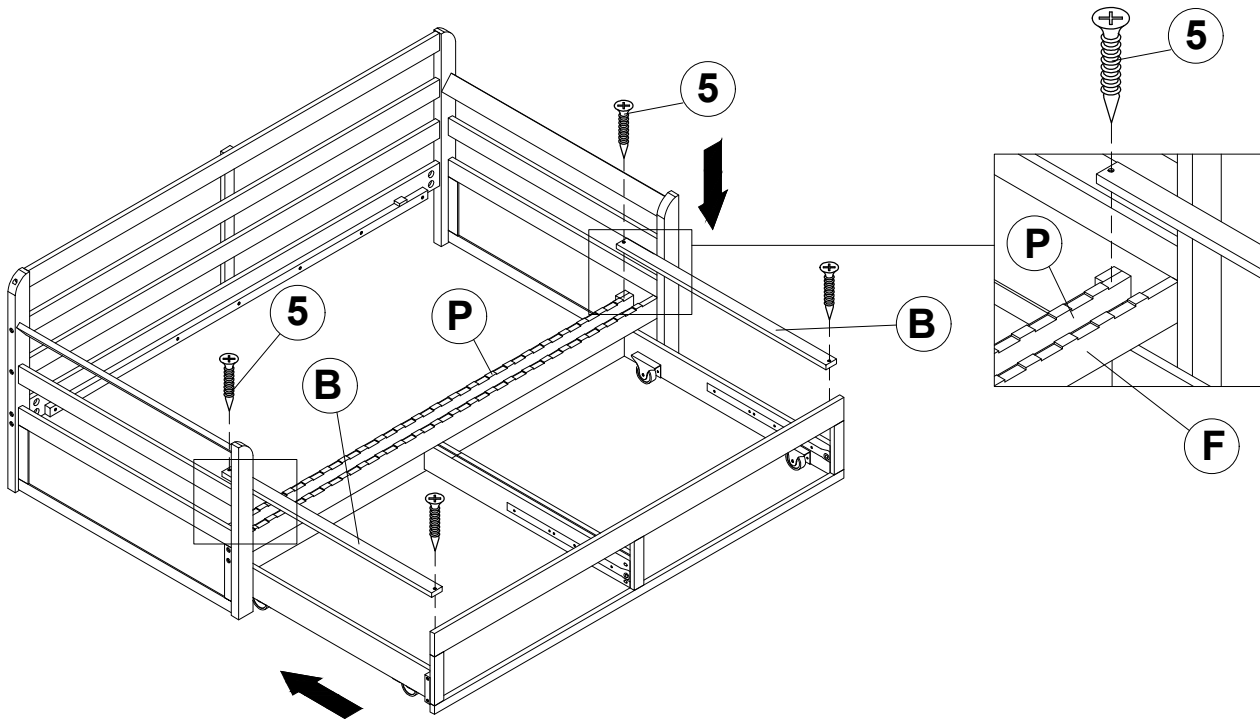

STEP 6

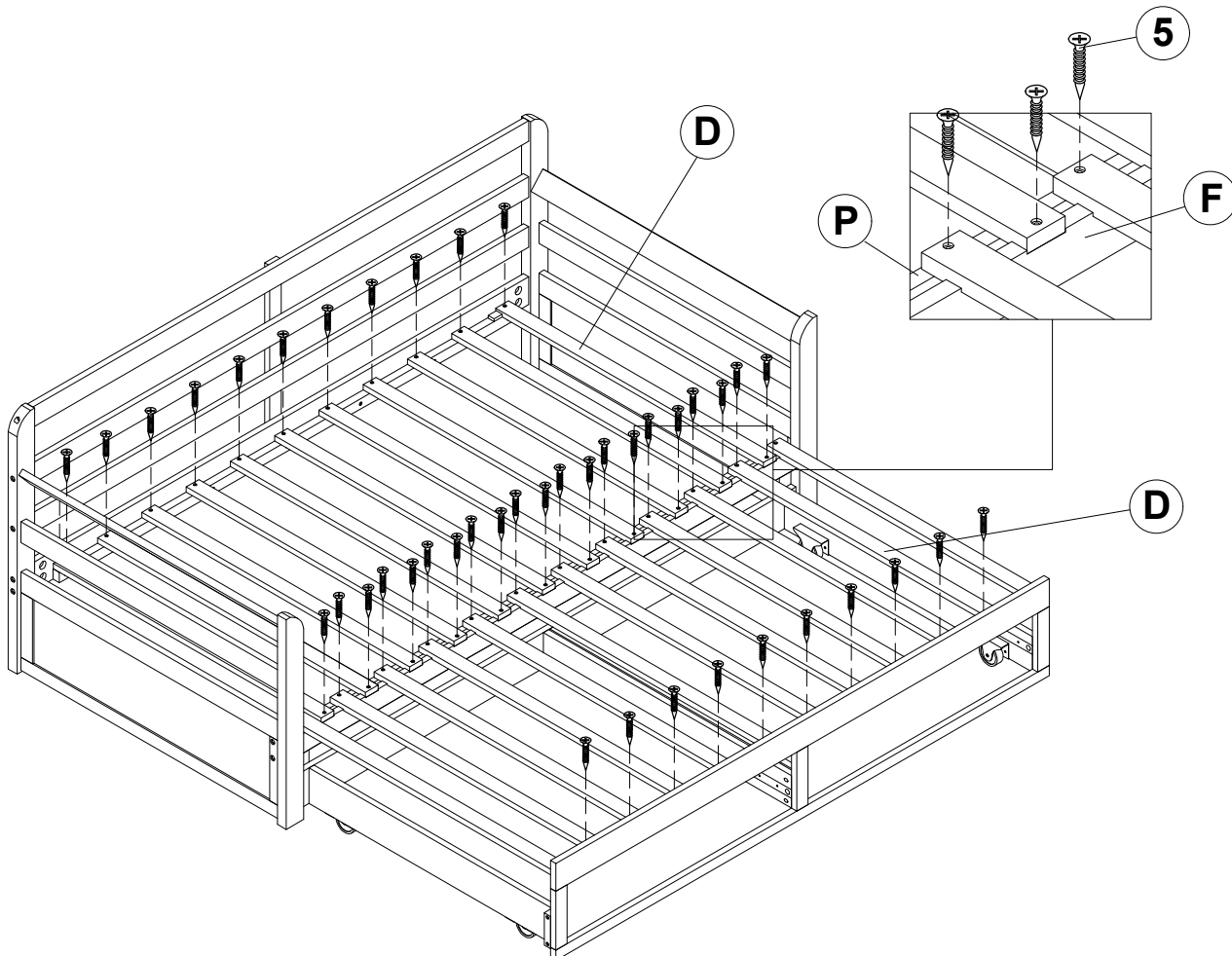

ITEM: **305706 (B1&B2)**
ASSEMBLY INSTRUCTIONS

STEP 7

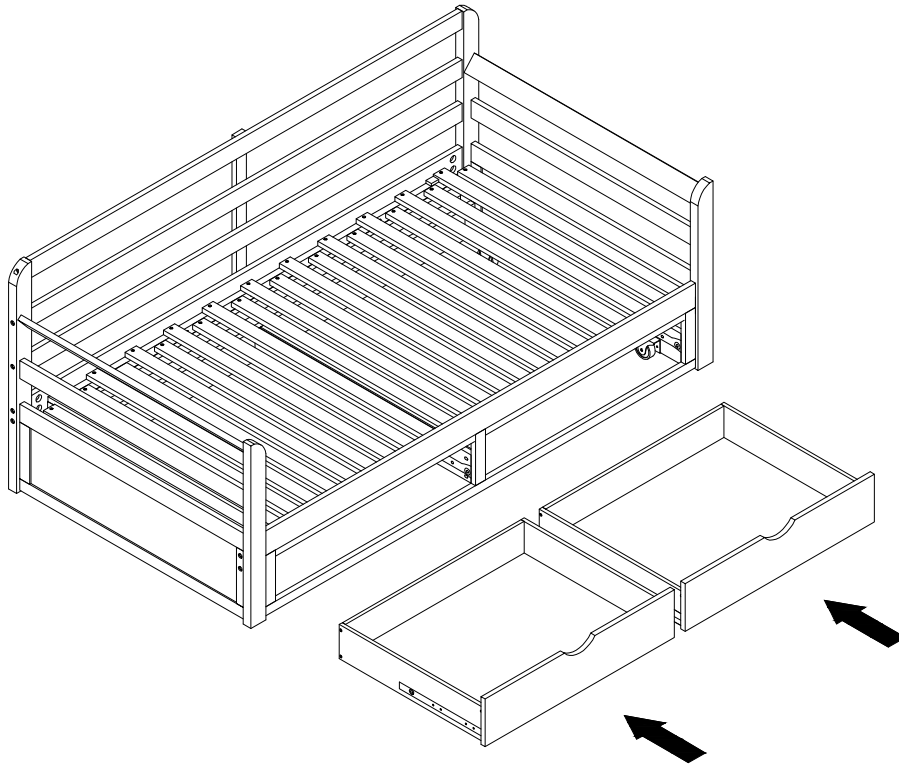

STEP 8
COMPLETE

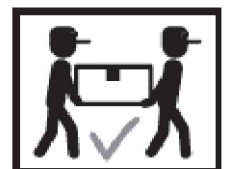
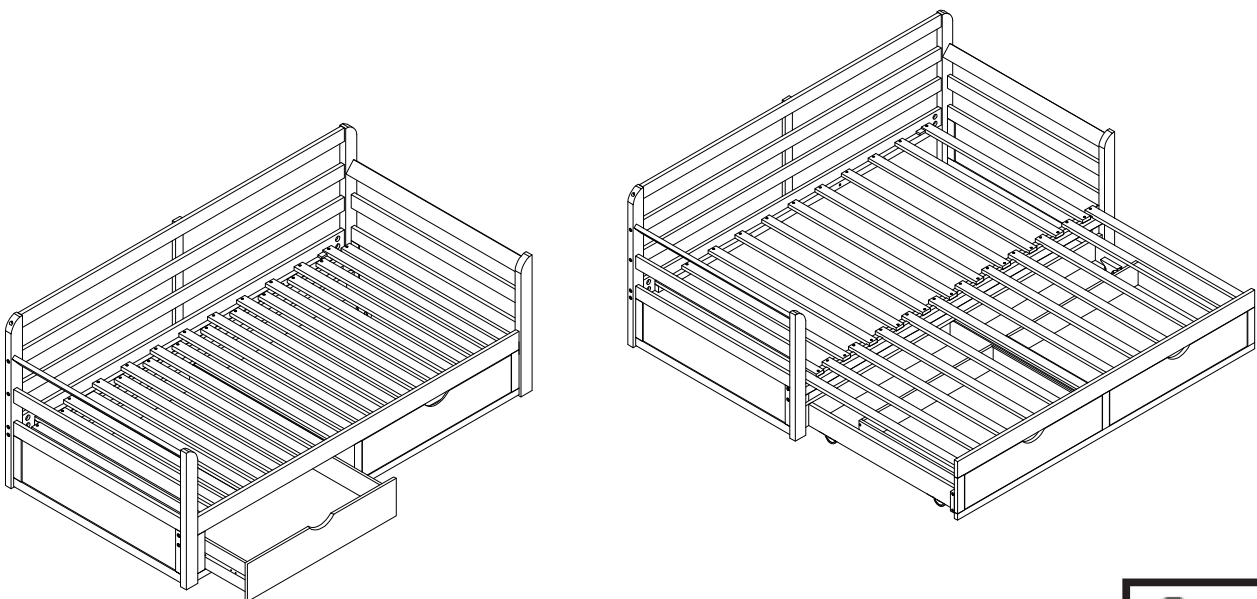

ITEM: 305706 (B1&B2)

Inner Size of Twin XL bed : 80.75"W x 41.25"D

Inner Size of King bed : 80.75"W x 79.00"D

Inner Size of Drawer : 35.50"W x 15.75"D x 3.25"H x 0.50"T

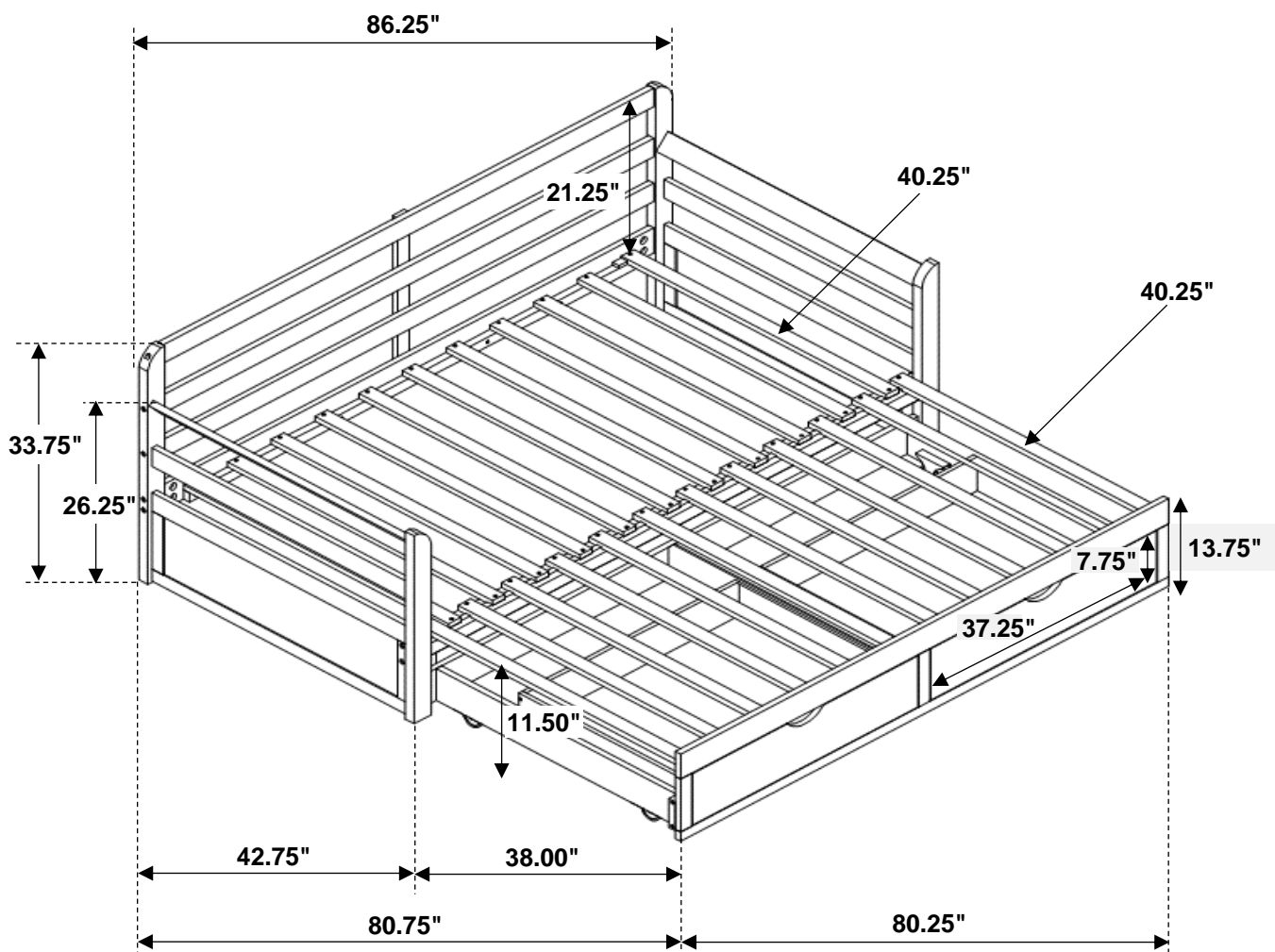

Note: Dimension tolerance $\pm 5\%$