

ASSEMBLY INSTRUCTIONS
COASTER FINE FURNITURE



Fine Furniture for every stage of life

205111Q (B1-B3)
Queen Storage Bed

REVISION 0 : 08/08/2016
REVISION 1 : 05/26/2017
REVISION 2 : 06/30/2017
REVISION 3 : 09/04/2018
REVISION 4 : 12/07/2018
REVISION 5 : 10/25/2019
REVISION 6 : 12/14/2023

ITEM: 205111Q (B1-B3)

ASSEMBLY INSTRUCTIONS

ASSEMBLY TIPS:

1. Remove hardware from box and sort by size.
2. Please check to see that all hardware and parts are present prior to start of assembly.
3. Please follow attached instructions in the same sequence as numbered to assure fast & easy assembly.



WARNING!

1. Don't attempt to repair or modify parts that are broken or defective. Please contact the store immediately.
2. This product is for home use only and not intended for commercial establishments.



ASSEMBLY TIME

20 MINUTES

PARTS IDENTIFICATION

B1 (BOX 1)

A HEADBOARD PANEL



1PC

B FOOTBOARD

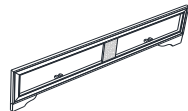

1PC

C RIGHT HEADBOARD LEG



1PC

D LEFT HEADBOARD LEG

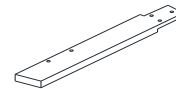

1PC

B2 (BOX 2)

E BED RAIL

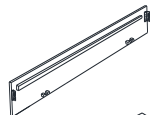

2PCS

F CONCEAL PANEL



5PCS

G BED SLAT

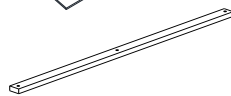

3PCS

G2 BED SLAT WITH STOPPER

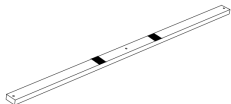

2PCS

H BED SLAT SUPPORT WITH LEVELER



5PCS

I DRAWER BOTTOM TRESTLE BAR

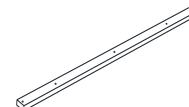

1PC

J DRAWER SUPPORT RAIL



2PCS

K DRAWER SUPPORT LEG WITH LEVELER



1PC

B3 (BOX 3)

L DRAWER BOX

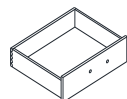

2PCS

HB 205111Q(B1) FROM BOX 1 HEADBOARD COMPLETE

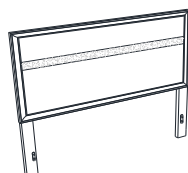

1PC

B 205111Q(B1) FROM BOX 1 FOOTBOARD

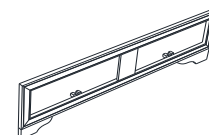

1PC

ITEM: 205111Q (B1-B3)



ASSEMBLY INSTRUCTIONS

ASSEMBLY TIPS:

1. Remove hardware from box and sort by size.
2. Please check to see that all hardware and parts are present prior to start of assembly.
3. Please follow attached instructions in the same sequence as numbered to assure fast & easy assembly.







WARNING!









1. Don't attempt to repair or modify parts that are broken or defective. Please contact the store immediately.
2. This product is for home use only and not intended for commercial establishments.

HARDWARE IDENTIFICATION

Z-B1 (BOX 1) - HARDWARE PACK IS LOCATED IN 205111Q (B1)

1	BOLT (M6 x 30mm - BLK)		6PCS	3	FLAT WASHER (1/4"ID x 13mm - BLK)		6PCS
2	LOCK WASHER (1/4" - BLK)		6PCS	4	ALLEN WRENCH (M4 x 60mm - BLK)		1PC

Z-B2 (BOX 2) - HARDWARE PACK IS LOCATED IN 205111Q (B2)

5	FLAT HEAD SCREW (M4 x 32mm - RBW)		14PCS	9	LOCK WASHER (1/4" - BLK)		2PCS
6	PAN HEAD SCREW (M3.5 x 20mm - BLK)		25PCS	10	FLAT WASHER (1/4"ID x 13mm - BLK)		2PCS
7	SHORT BOLT (M6 x 35mm - BLK)		2PCS	11	SMALL ALLEN WRENCH (M4 x 60mm - BLK)		1PC
8	LONG BOLT (M6 x 50mm - BLK)		6PCS	12	BIG ALLEN WRENCH (M5 x 68mm - BLK)		1PC

NOTE:

Phillips head screw driver is required in the assembly process; however, manufacturer does not provide this item.

ASSEMBLY INSTRUCTIONS

STEP 1

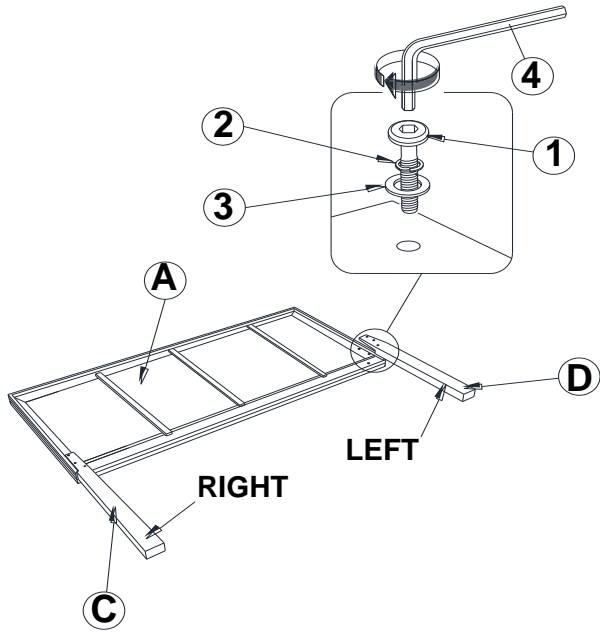

****BACK VIEW****

Note : Please take note of the marking sticker (L&R) on the leg.

STEP 2

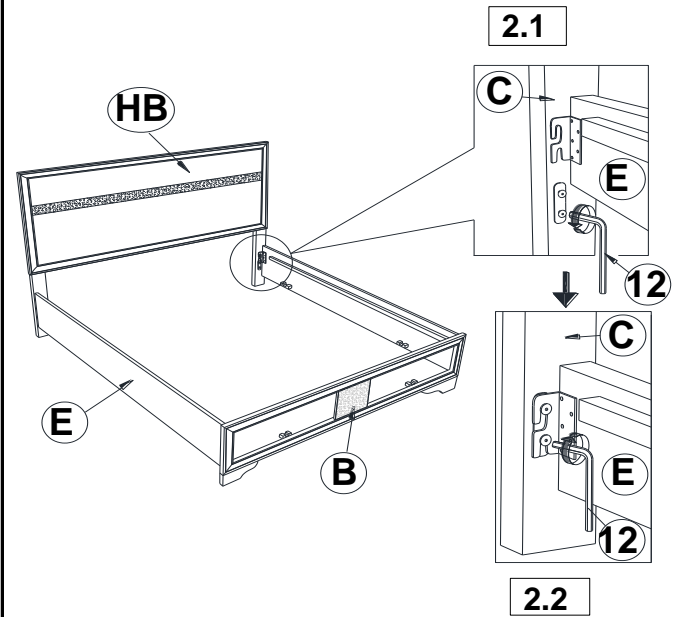

STEP 3

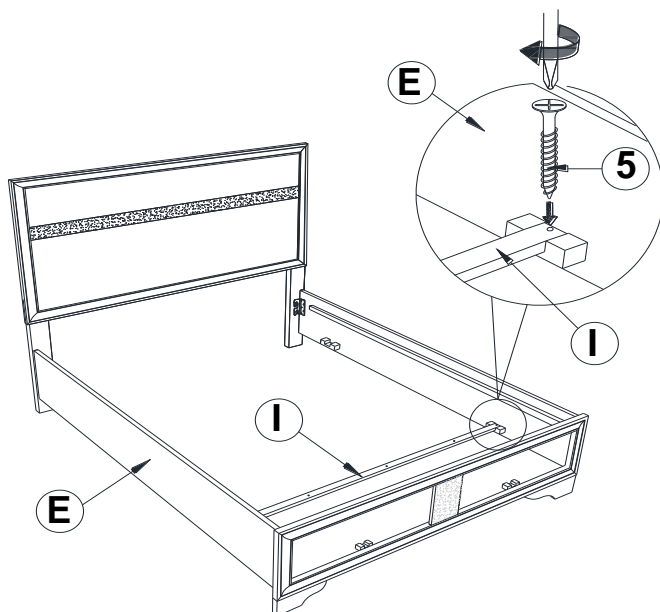

STEP 4

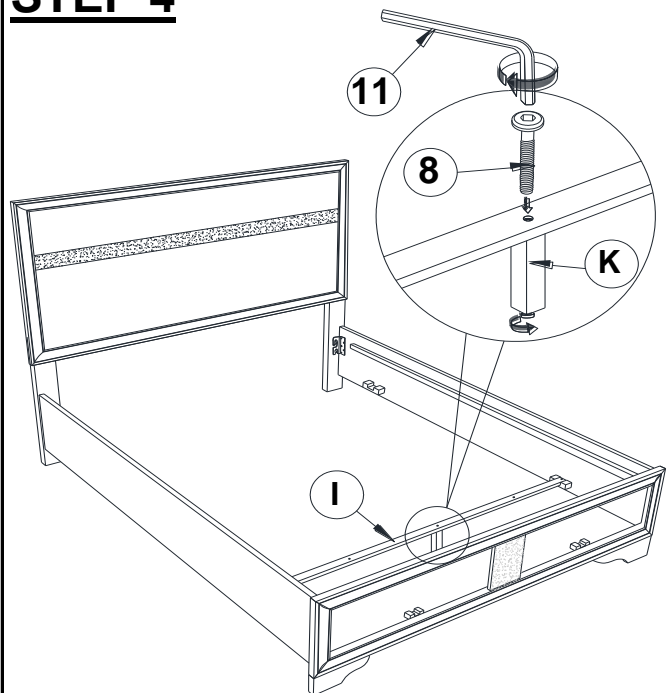

ASSEMBLY INSTRUCTIONS

STEP 5

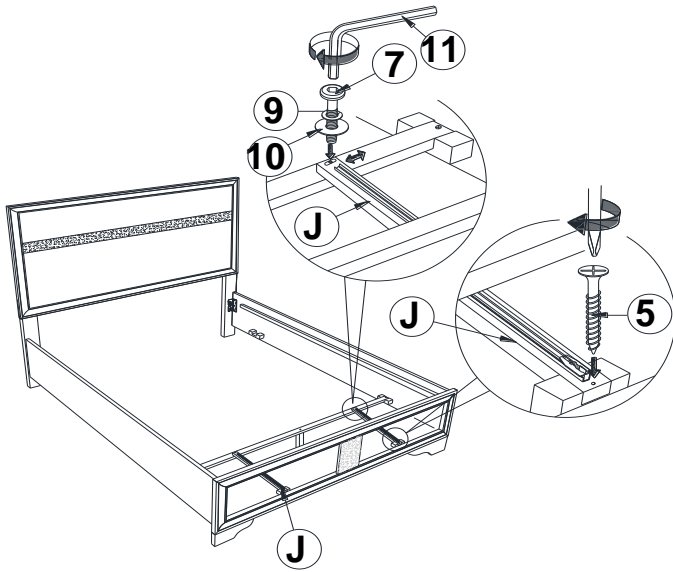

STEP 6

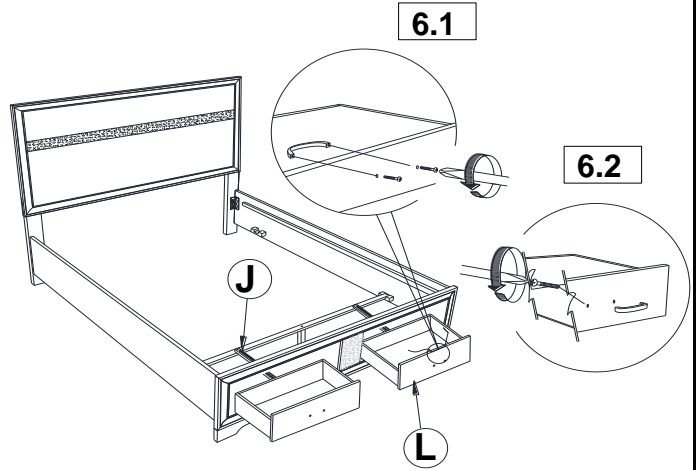

STEP 7

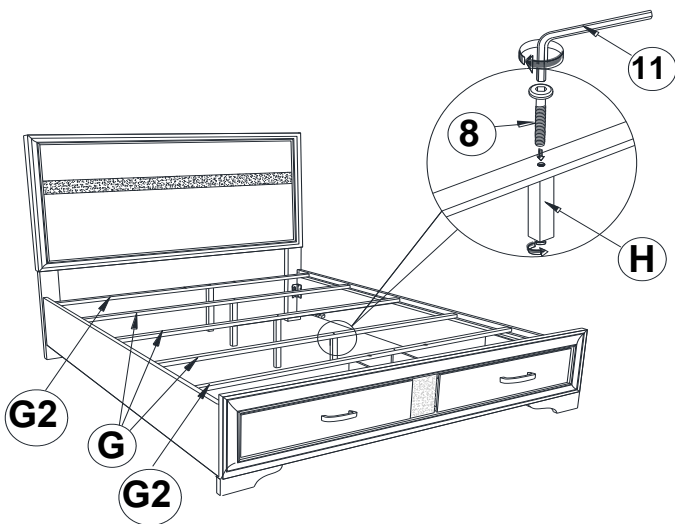

STEP 8

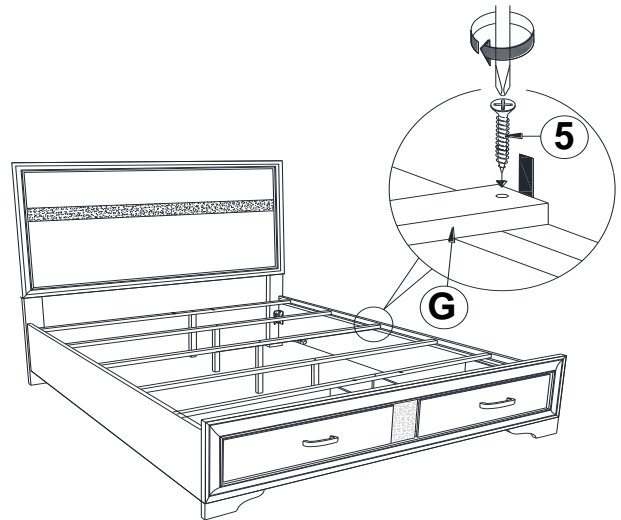

ITEM: **205111Q (B1-B3)**



ASSEMBLY INSTRUCTIONS

STEP 9

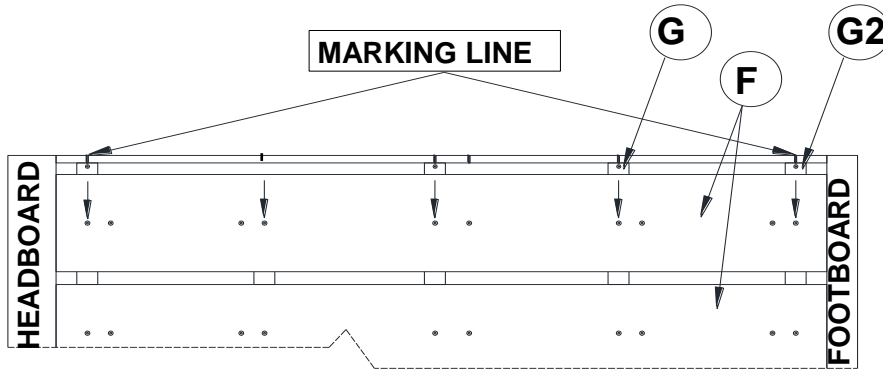

TIGHTEN THE PANHEAD SCREW (6) BY FOLLOW THE ARROW AS SHOWN

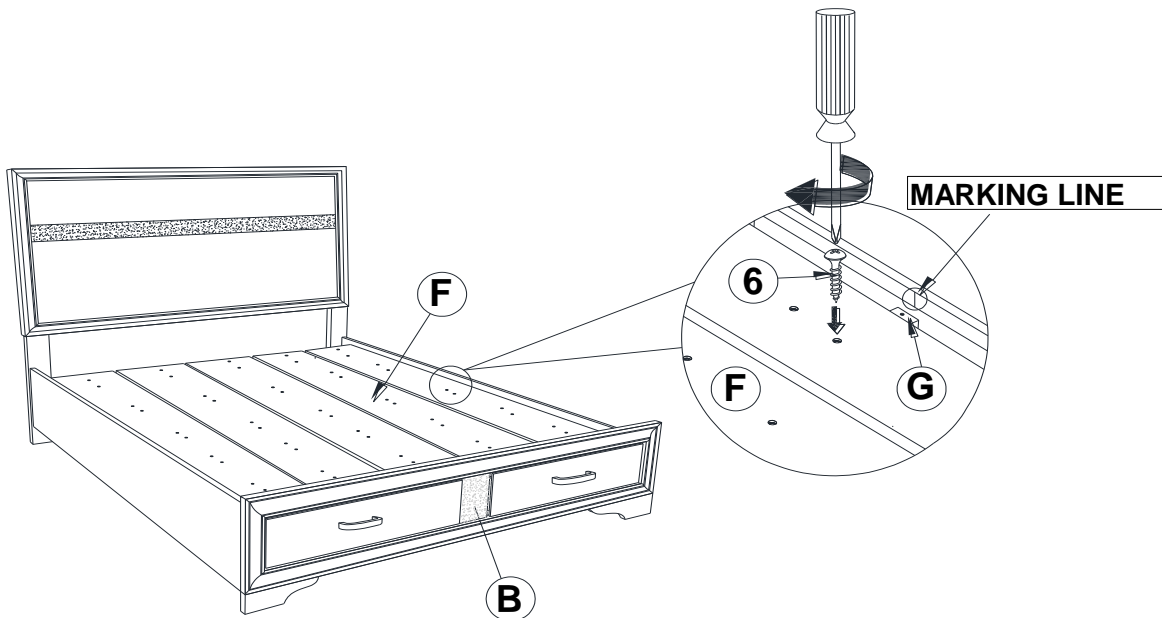

STEP 10
COMPLETE

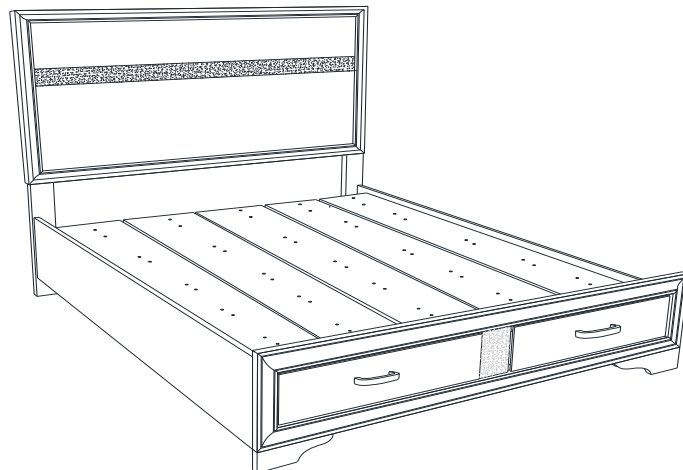

ITEM: **205111Q (B1-B3)**



Inner Size of Bed: 60.75"W X 81.00"D

Inner Size of Drawer : 4.00"W X 15.00"D X 23.25"H X 0.25"T

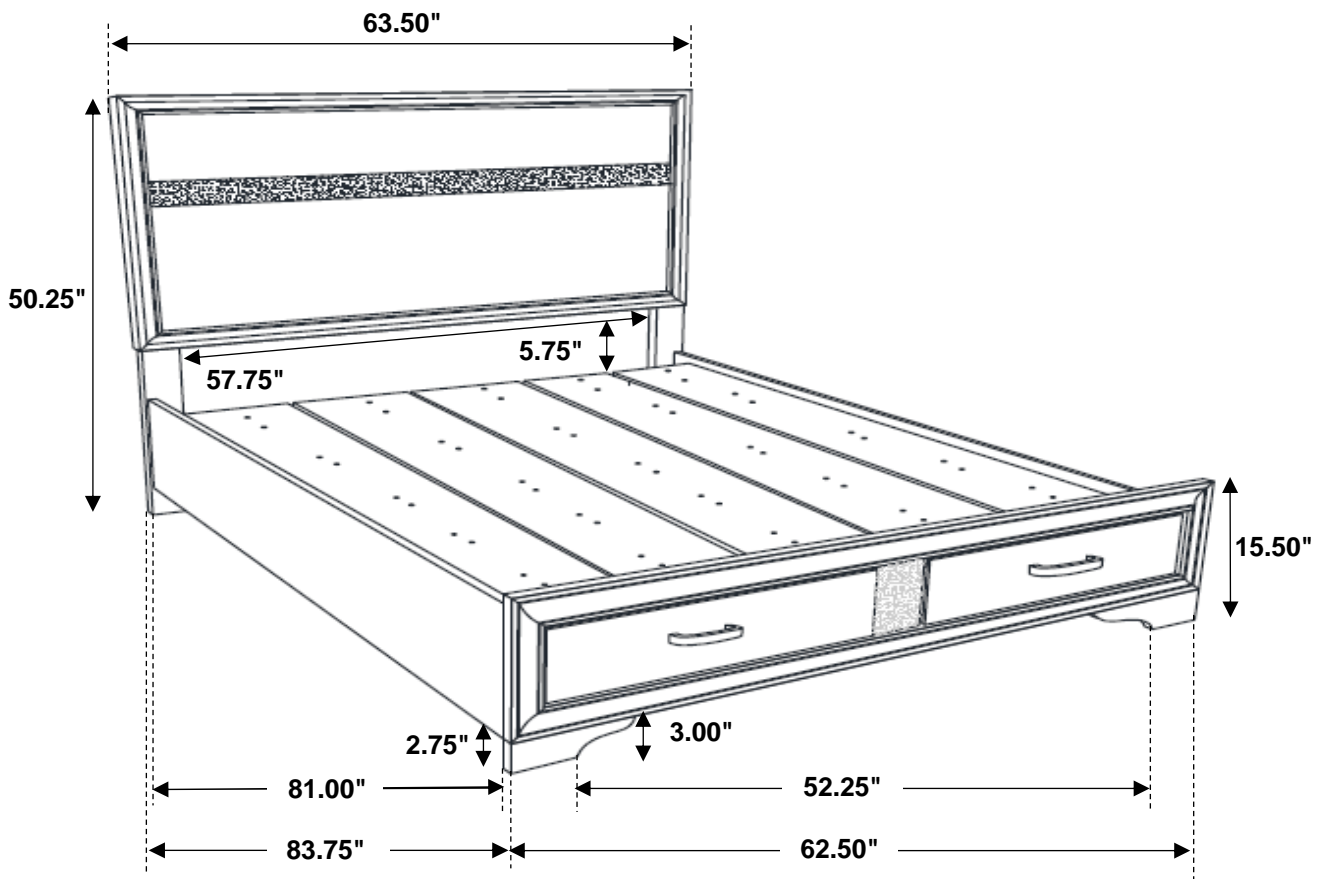

Note: Dimension tolerance $\pm 5\%$