

**ASSEMBLY INSTRUCTIONS**  
**COASTER FINE FURNITURE**



*Fine Furniture for every stage of life*

**205111T (B1-B3)**  
**Twin Storage Bed**

# ITEM: 205111T (B1-B3)



## ASSEMBLY INSTRUCTIONS

### ASSEMBLY TIPS:

1. Remove hardware from box and sort by size.
2. Please check to see that all hardware and parts are present prior to start of assembly.
3. Please follow attached instructions in the same sequence as numbered to assure fast & easy assembly.



### WARNING!

1. Don't attempt to repair or modify parts that are broken or defective. Please contact the store immediately.
2. This product is for home use only and not intended for commercial establishments.



ASSEMBLY TIME

20 MINUTES

## PARTS IDENTIFICATION

### B1 ( BOX 1 )

A HEADBOARD PANEL

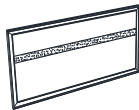

1PC

B FOOTBOARD

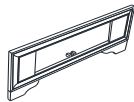

1PC

C RIGHT HEADBOARD LEG



1PC

D LEFT HEADBOARD LEG

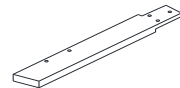

1PC

### B2 ( BOX 2 )

E BED RAIL

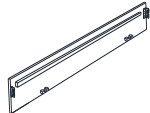

2PCS

F CONCEAL PANEL

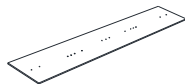

3PCS

G BED SLAT



3PCS

G2 BED SLAT WITH STOPPER

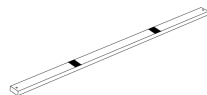

2PCS

H DRAWER BOTTOM TRESTLE BAR

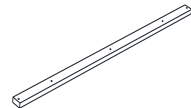

1PC

I DRAWER SUPPORT RAIL



1PC

J DRAWER SUPPORT LEG WITH LEVELER



1PC

### B3 ( BOX 3 )

K DRAWER BOX

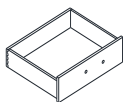

1PC

HB 205111T(B1) FROM BOX 1 HEADBOARD COMPLETE



1PC

B 205111T(B1) FROM BOX 1 FOOTBOARD

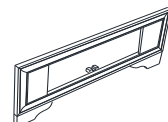

1PC

# ITEM: 205111T (B1-B3)



## ASSEMBLY INSTRUCTIONS

### ASSEMBLY TIPS:

1. Remove hardware from box and sort by size.
2. Please check to see that all hardware and parts are present prior to start of assembly.
3. Please follow attached instructions in the same sequence as numbered to assure fast & easy assembly.







### WARNING!









1. Don't attempt to repair or modify parts that are broken or defective. Please contact the store immediately.
2. This product is for home use only and not intended for commercial establishments.

## HARDWARE IDENTIFICATION

### Z-B1 (BOX 1) - HARDWARE PACK IS LOCATED IN 205111T (B1)

1	<b>BOLT</b> (M6 x 30mm - BLK)		6PCS	3	<b>FLAT WASHER</b> (1/4"ID x 13mm - BLK)		6PCS
2	<b>LOCK WASHER</b> (1/4" - BLK)		6PCS	4	<b>ALLEN WRENCH</b> (M4 x 60mm - BLK)		1PC

### Z-B2 (BOX 2) - HARDWARE PACK IS LOCATED IN 205111T (B2)

5	<b>FLAT HEAD SCREW</b> (M4 x 32mm - RBW)		13PCS	9	<b>LOCK WASHER</b> (1/4" - BLK)		1PC
6	<b>PAN HEAD SCREW</b> (M3.5 x 20mm - BLK)		15PCS	10	<b>FLAT WASHER</b> (1/4"ID x 13mm - BLK)		1PC
7	<b>SHORT BOLT</b> (M6 x 35mm - BLK)		1PC	11	<b>SMALL ALLEN WRENCH</b> (M4 x 60mm - BLK)		1PC
8	<b>LONG BOLT</b> (M6 x 50mm - BLK)		1PC	12	<b>BIG ALLEN WRENCH</b> (M5 x 65mm - BLK)		1PC

### NOTE:

Phillips head screw driver is required in the assembly process; however, manufacturer does not provide this item.

**ASSEMBLY INSTRUCTIONS**

**STEP 1**

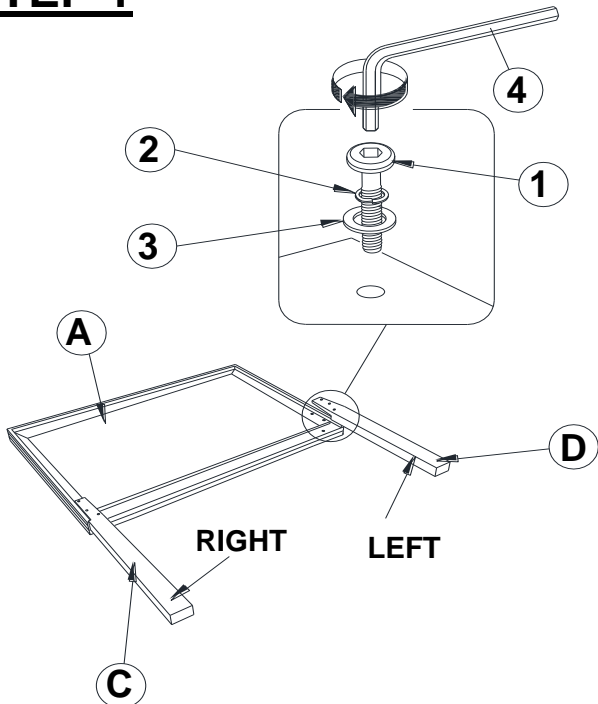

**\*\*BACK VIEW\*\***

Note : Please take note of the marking sticker (L&R) on the leg.

**STEP 2**

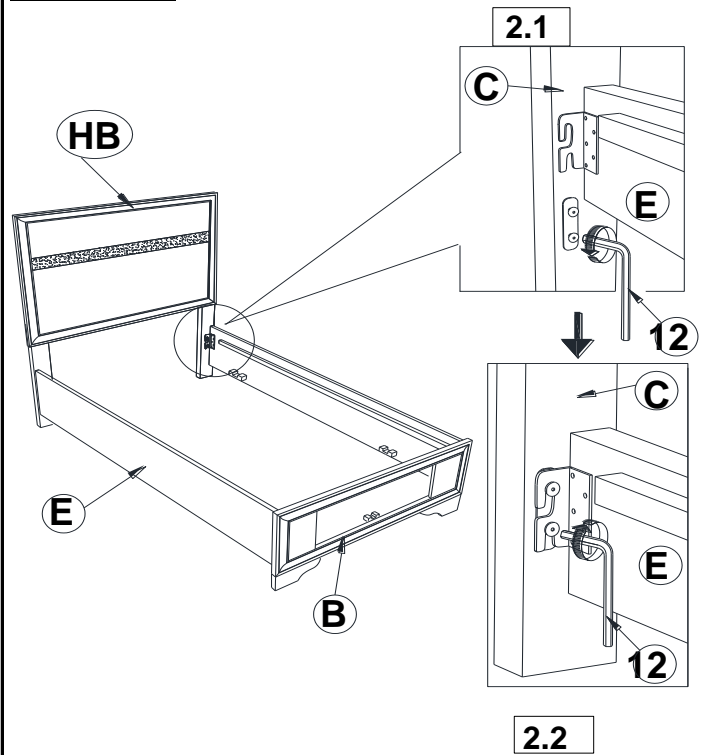

**STEP 3**

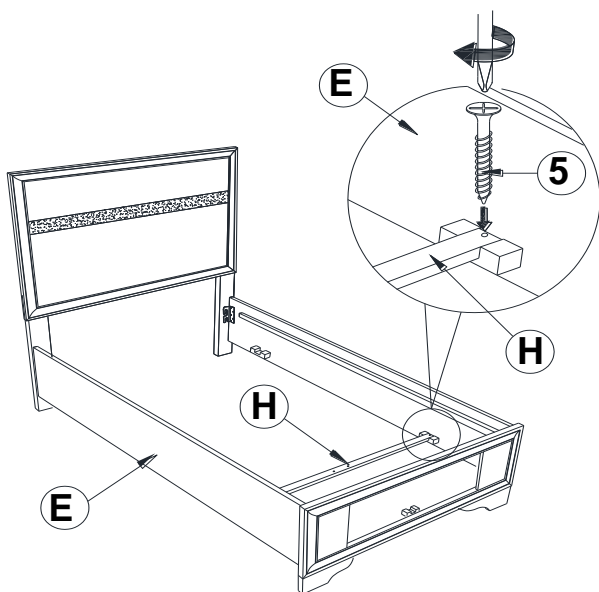

**STEP 4**

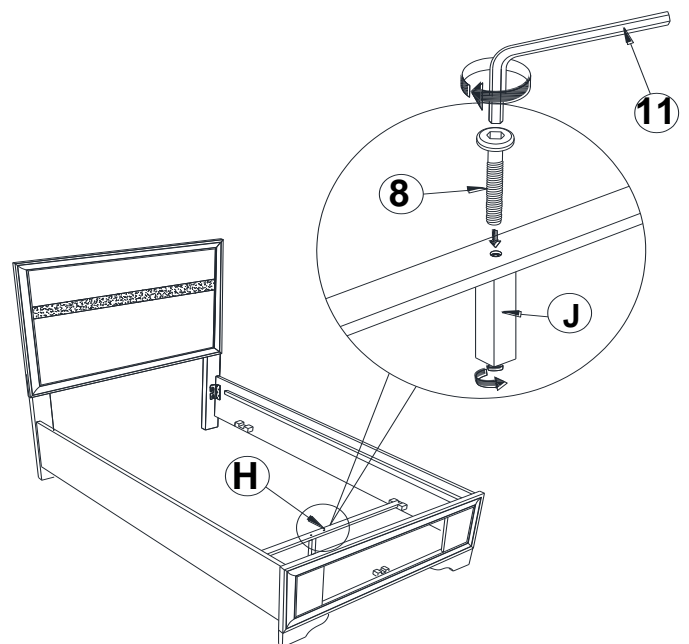

# ITEM: 205111T (B1-B3)

## ASSEMBLY INSTRUCTIONS

### STEP 5

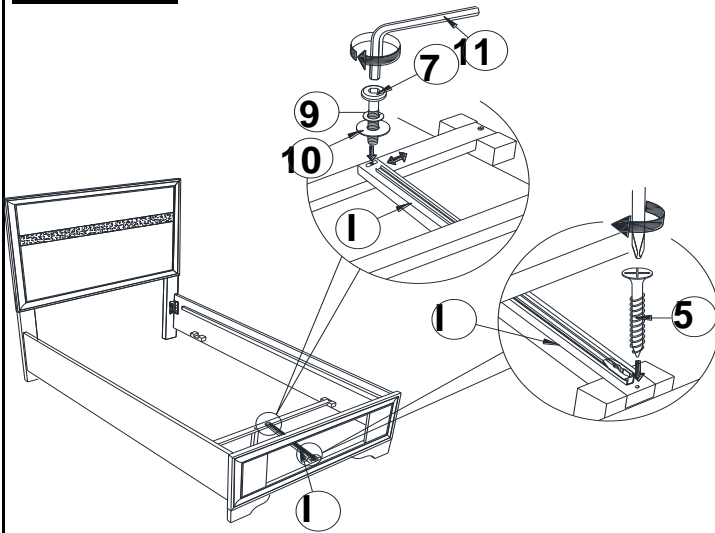

### STEP 6

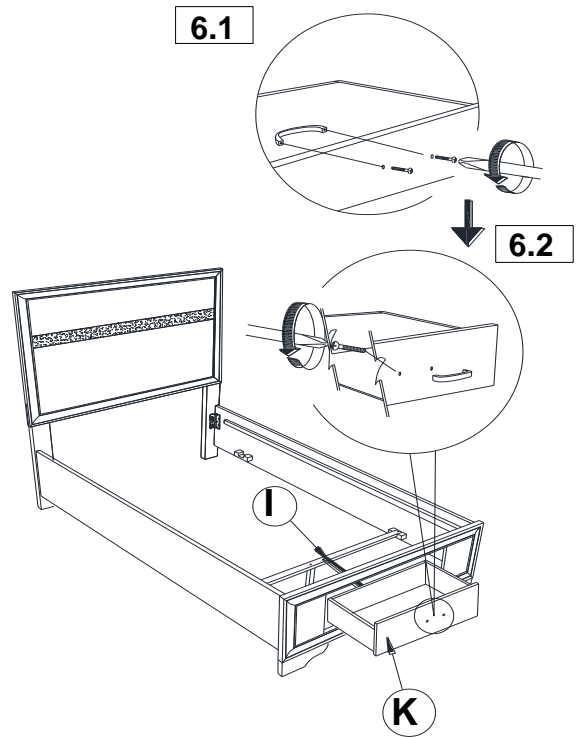

### STEP 7

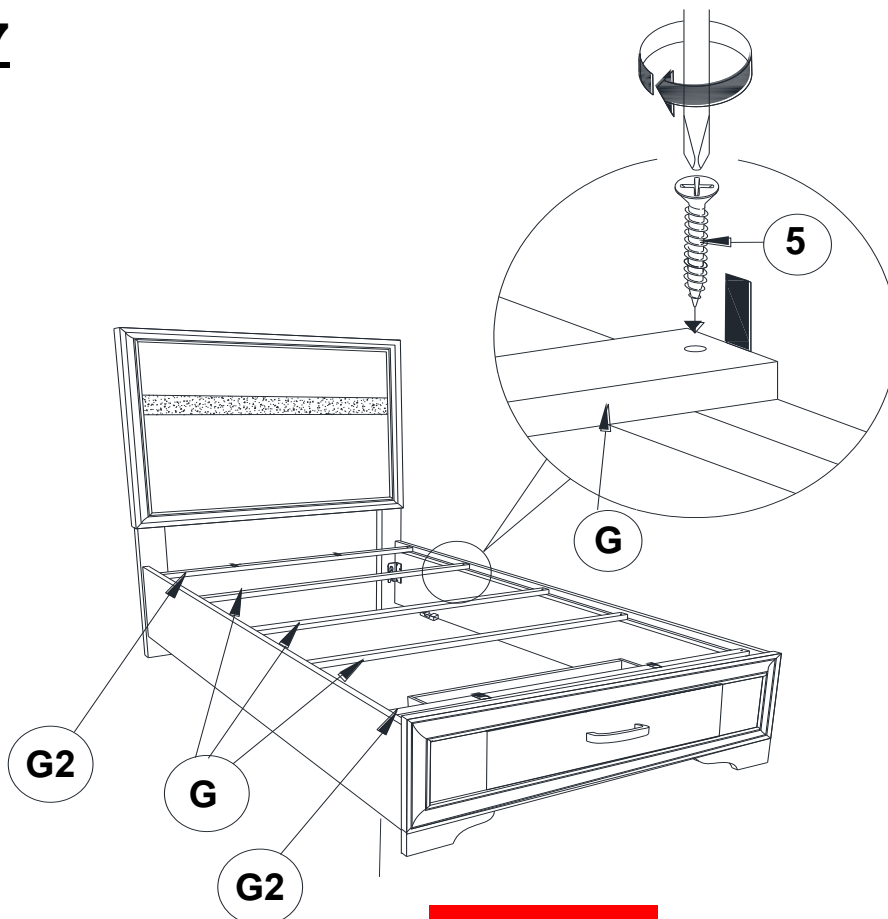

**ASSEMBLY INSTRUCTIONS**

**STEP 8**

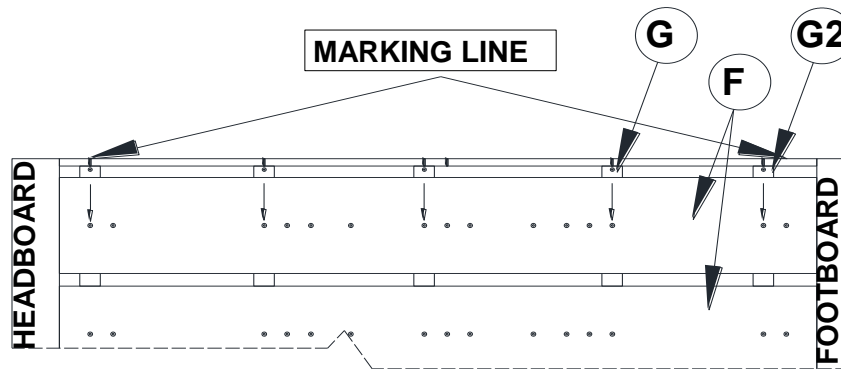

**TIGHTEN THE PANHEAD SCREW (6) BY FOLLOW THE ARROW AS SHOWN**

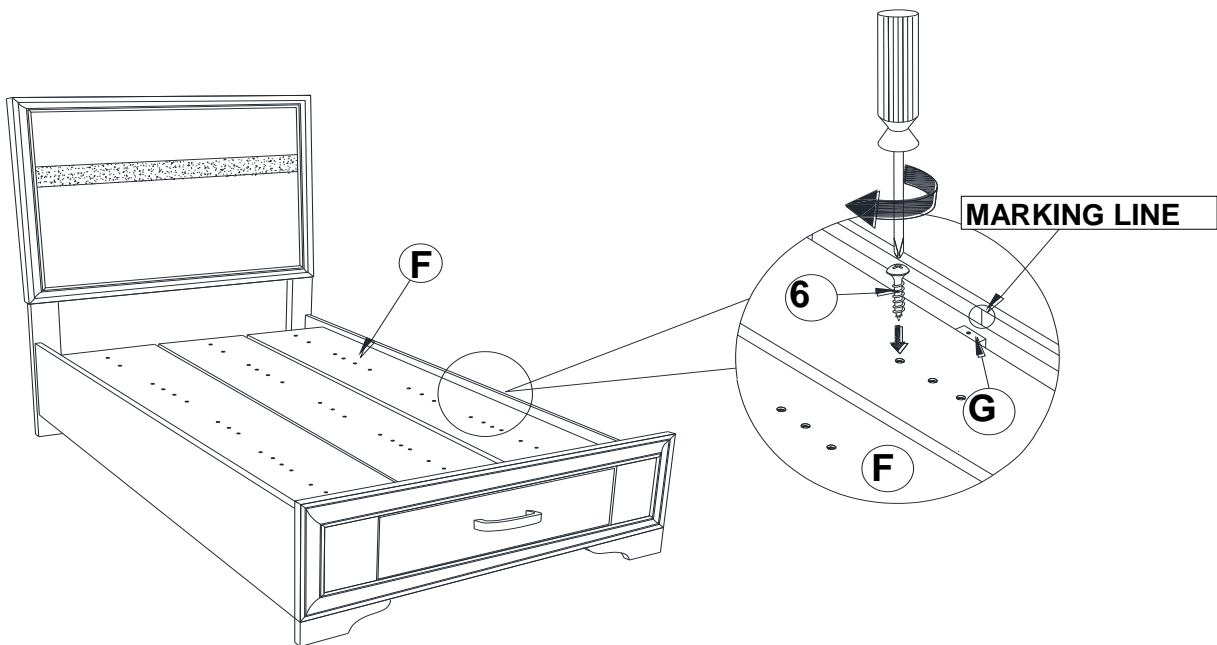

**STEP 9**  
**COMPLETE**

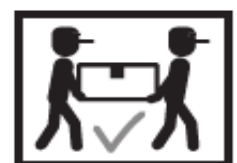
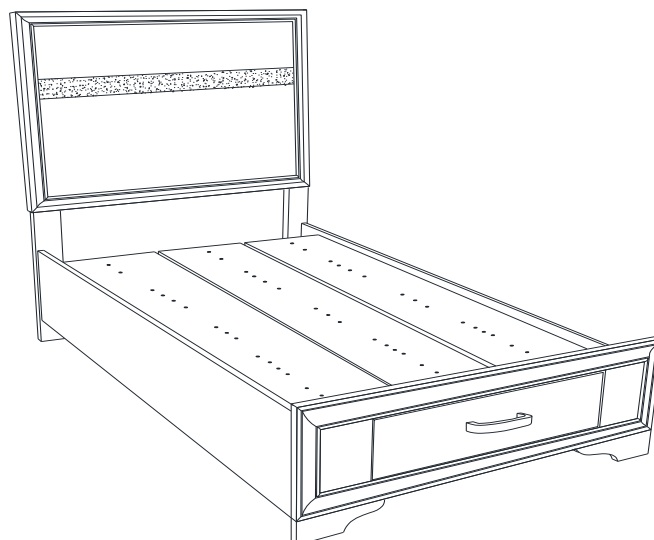

# ITEM: 205111T (B1-B3)



Inner Size: 54.50"W X 76.00"D

Inner Size of Drawer: 20.00"W X 15.00"D X 4.00"H X 0.25"T

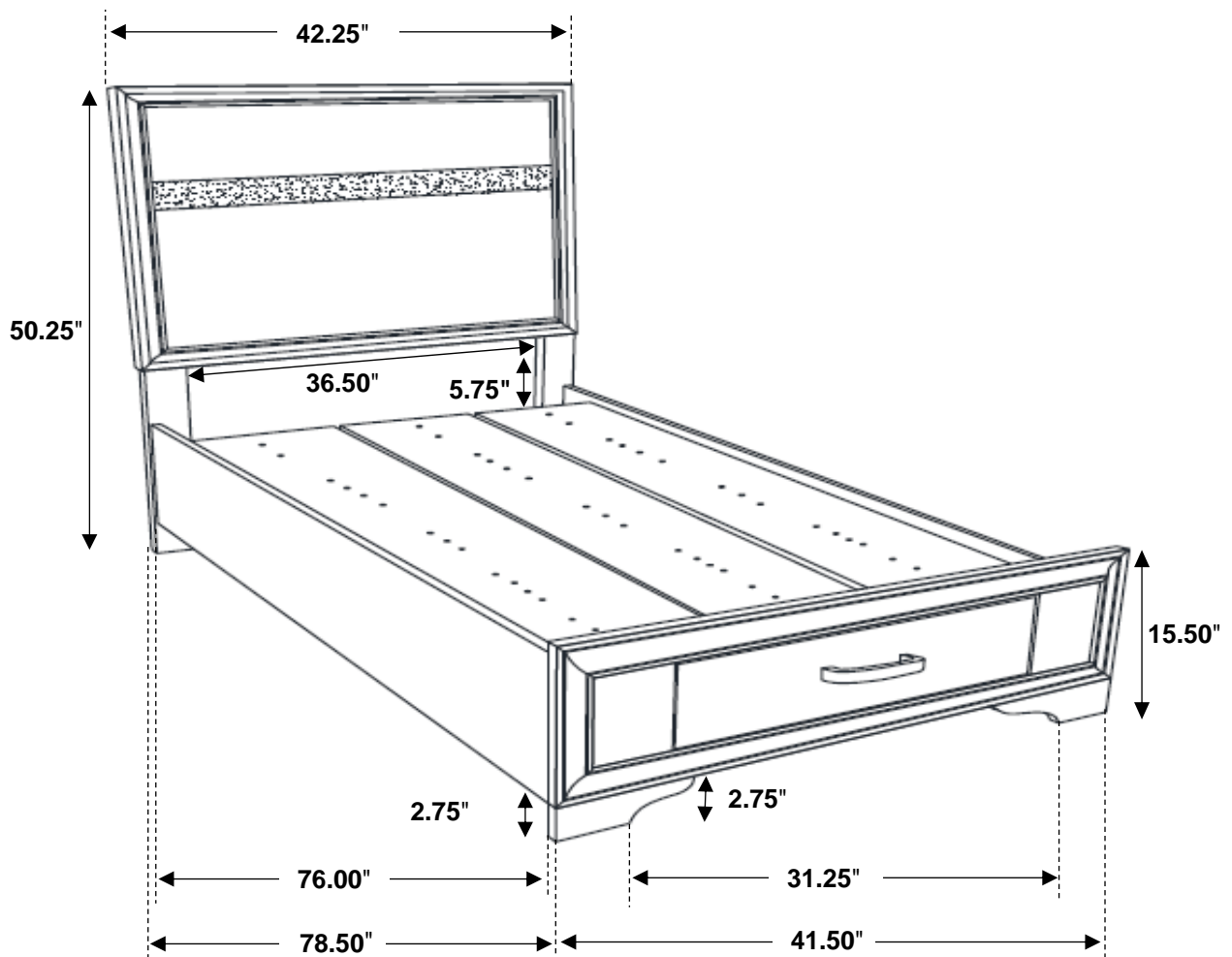

Note: Dimension tolerance  $\pm 5\%$