

**ASSEMBLY INSTRUCTIONS**  
**COASTER FINE FURNITURE**



*Fine Furniture for every stage of life*

**801296**  
**OFFICE CHAIR**

REVISION 0:12/05/2018  
REVISION 1:06/04/2019  
REVISION 2:11/25/2019  
REVISION 3:01/06/2020  
REVISION 4:07/31/2021  
REVISION 5:07/14/2022

ITEM: 801296



# ASSEMBLY INSTRUCTIONS

### ASSEMBLY TIPS:

- 1.Remove hardware from box and sort by size.
- 2.Please check to see that all hardware and parts are present prior to start of assembly.
- 3.Please follow attached instructions in the same sequence as numbered to assure fast & easy assembly.











### WARNING !

- 1.Don't attempt to repair or modify parts that are broken or defective. Please contact the store immediately.
- 2.This product is for home uses only and not intended for commercial establishments.





**ASSEMBLY TIME 20 MINUTES**

## PARTS IDENTIFICATION

A		BACK	1PC
B		SEAT	1PC
C		RIGHT ARMREST	1PC
D		LEFT ARMREST	1PC
E		MECHANISM	1PC
F		GAS LIFT COVER	1PC
G		GAS LIFT	1PC
H		BASE	1PC
I		CASTER	5PCS

## HARDWARE IDENTIFICATION

1	LONG BOLT	 M6*30	8PCS
2	SHORT BOLT	 M6*20	4PCS
3	ALLEN WRENCH	 M6	1PC
4	MEDIUM BOLT CAP		8PCS
5	WASHER	 M6*18*1.2	4PCS

ITEM: 801296



# ASSEMBLY INSTRUCTIONS

## STEP 1

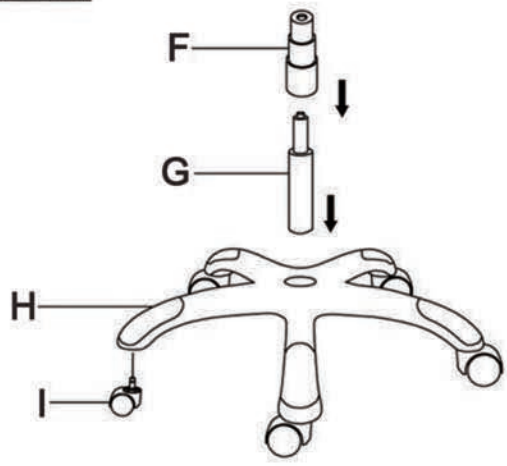

## STEP 2

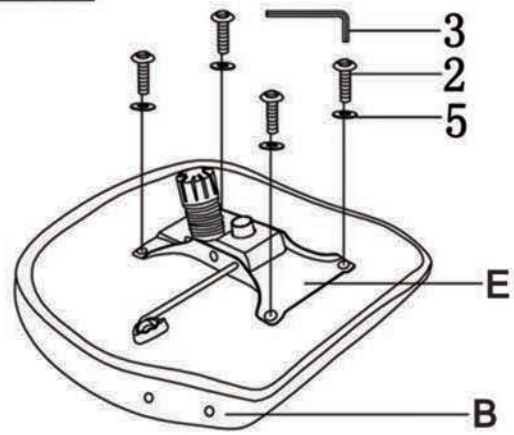

## STEP 3

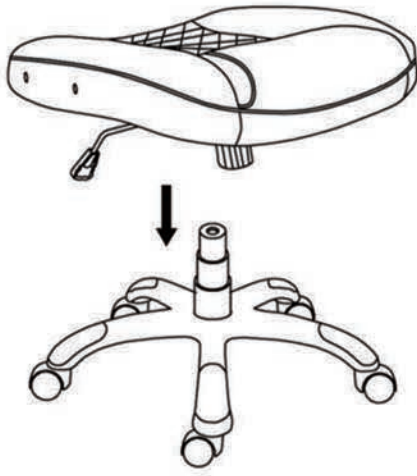

## STEP 4

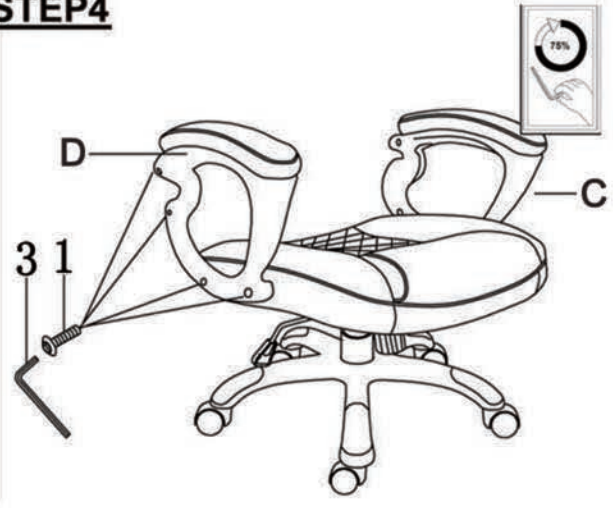

## STEP 5



## STEP 6

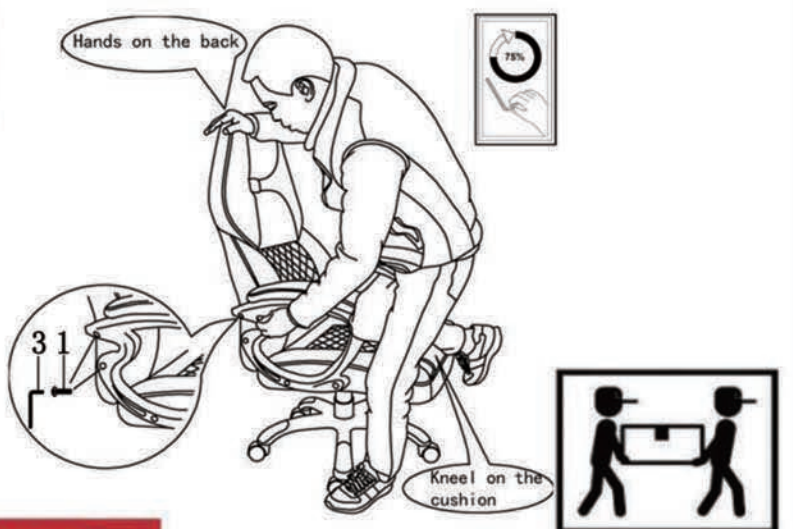

ITEM: 801296

# ASSEMBLY INSTRUCTIONS



## STEP 7



## STEP 8



## STEP 9

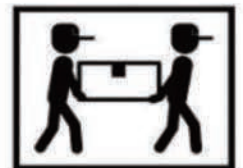

ITEM: 801296

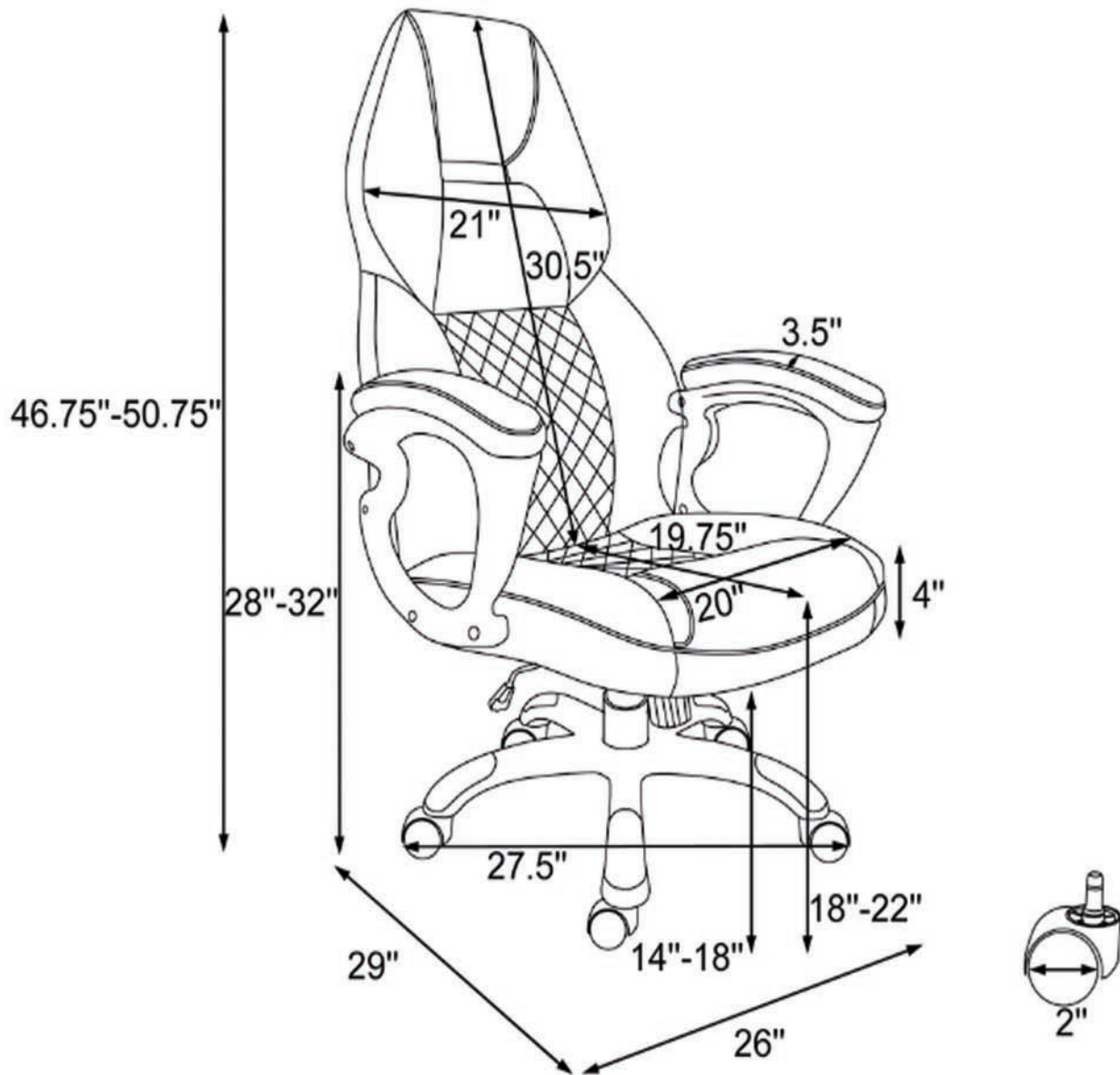

Note : Dimension tolerance  $\pm 5\%$