

ASSEMBLY INSTRUCTIONS
COASTER FINE FURNITURE



Fine Furniture for every stage of life

721618
COFFEE TABLE

ASSEMBLY INSTRUCTIONS

ASSEMBLY TIPS:

1. Remove hardware from box and sort by size.
2. Please check to see that all hardware and parts are present prior to start of assembly.
3. Please follow attached instructions in the same sequence as numbered to assure fast & easy assembly.



WARNING!

1. Don't attempt to repair or modify parts that are broken or defective. Please contact the store immediately.
2. This product is for home use only and not intended for commercial establishments.

ASSEMBLY TIME

15 MINUTES

PARTS IDENTIFICATION

B1 (BOX 1)

A TABLE TOP  1 PC

B2 (BOX 2)

B ROUND CONNECTING PLATE  1 PC

C BOTTOM SHELF  1 PC



D LEG  4 PCS

E TOP CROSSBAR  1 PC

F BOTTOM CROSSBAR  1 PC

ASSEMBLY INSTRUCTIONS

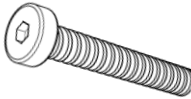
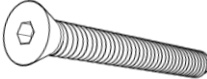
Z HARDWARE IDENTIFICATION

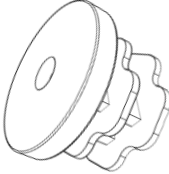
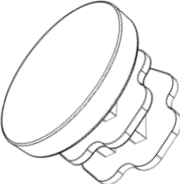
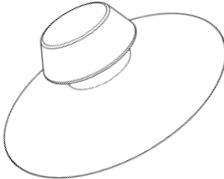
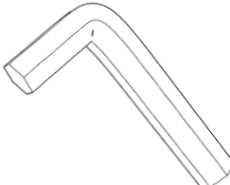
1	BOLT (1/4" x 38mm - BLK)		4 PCS
2	BOLT (1/4" x 44mm - BLK)		8 PCS
3	SCREW (Ø8 x 36mm - BLK)		4 PCS
4	CAP (Ø25 x 15mm - BLK)		4 PCS
5	CAP (Ø25 x 15mm - BLK)		4 PCS
6	SUCTION CUP (Ø20 x 11mm)		4 PCS
7	ALLEN WRENCH (4 x 57mm - SR)		1 PC

Hardware pack is located in 721618B2

ITEM:721618

ASSEMBLY INSTRUCTIONS

STEP 1

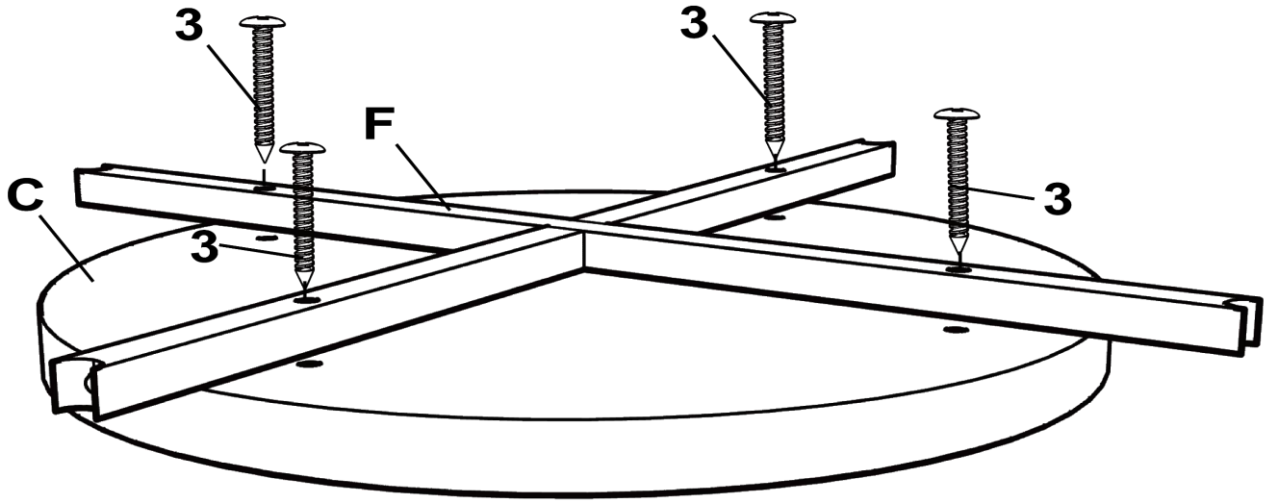

STEP 2

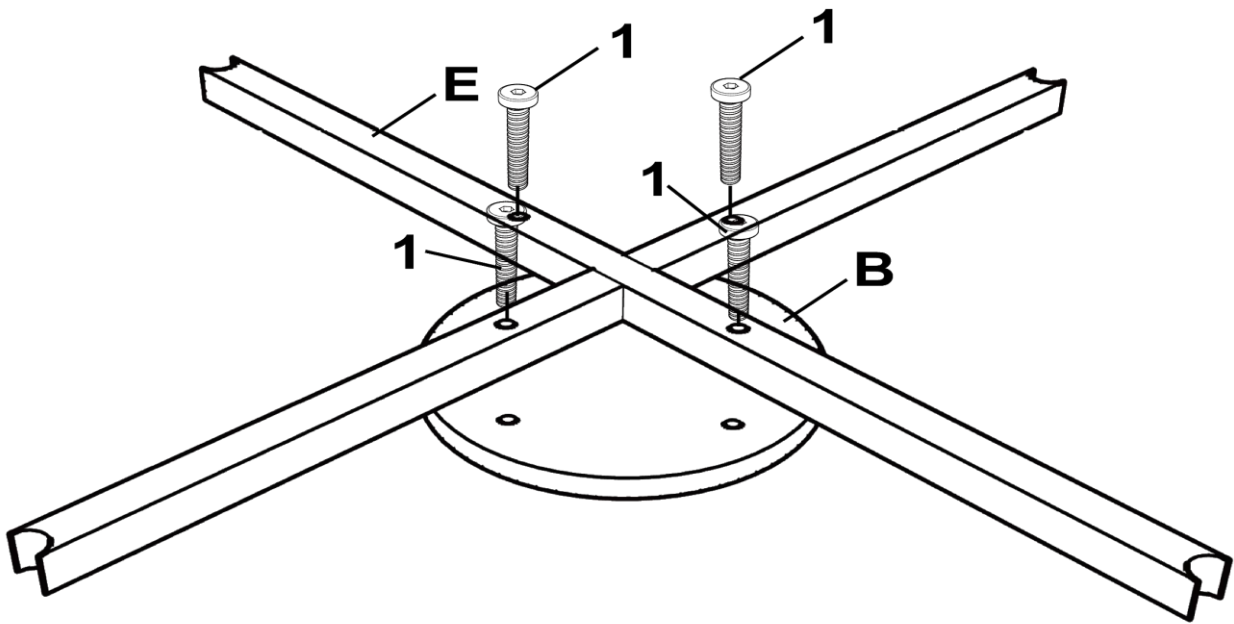

ITEM:721618

ASSEMBLY INSTRUCTIONS

STEP 3

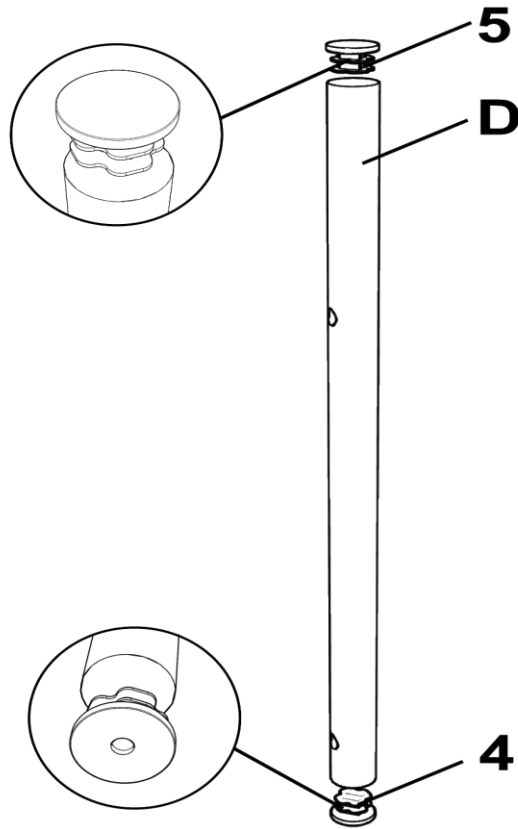

STEP 4

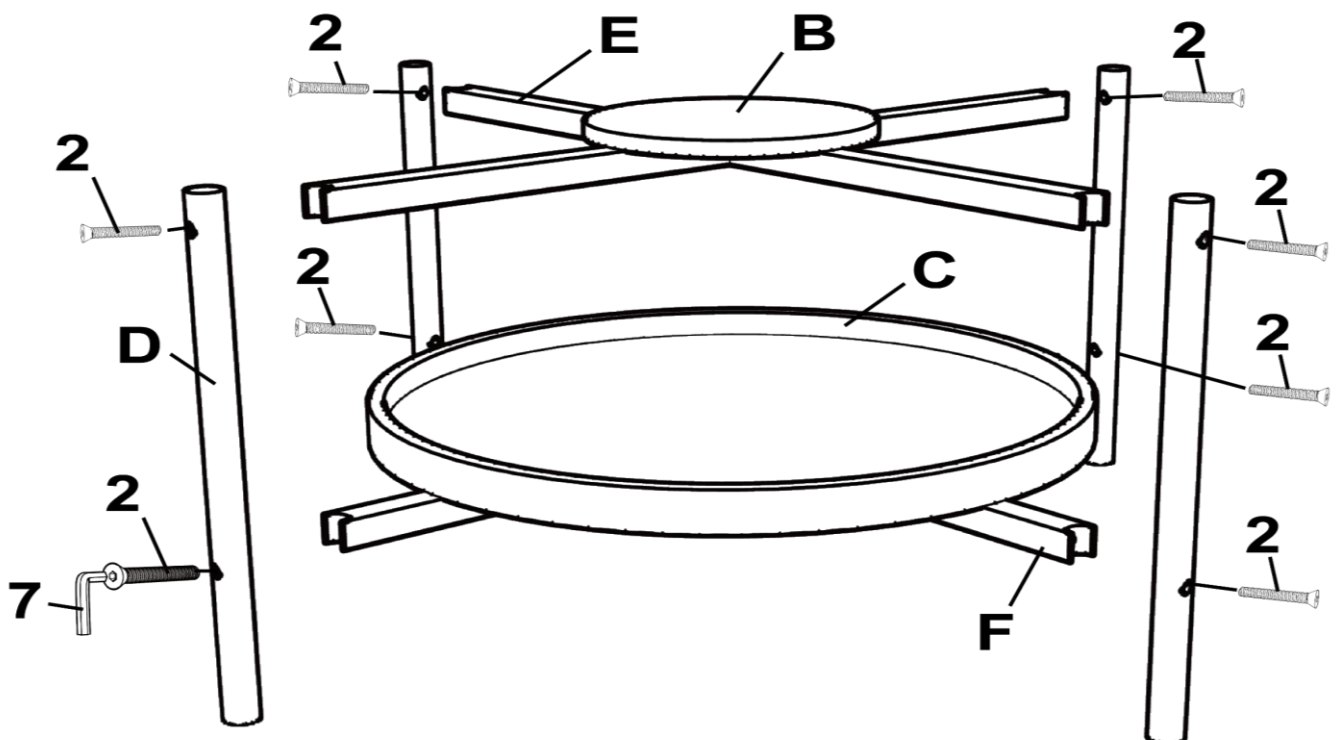

ITEM:721618

ASSEMBLY INSTRUCTIONS

STEP 5

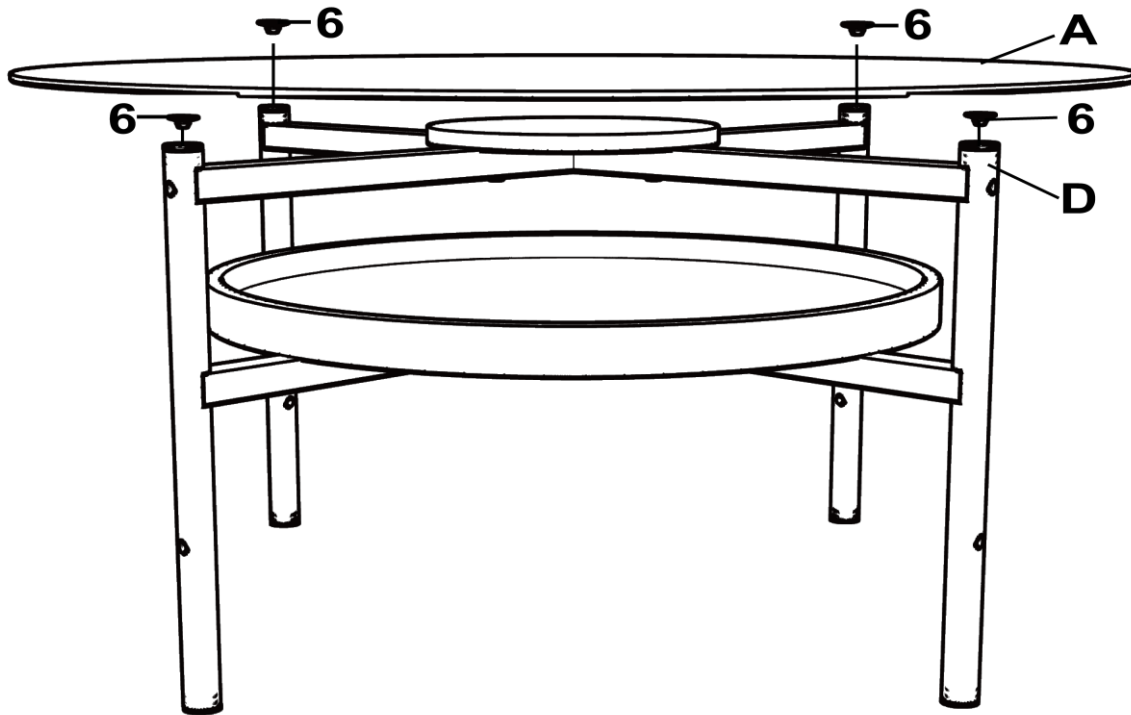

STEP 6

COMPLETE

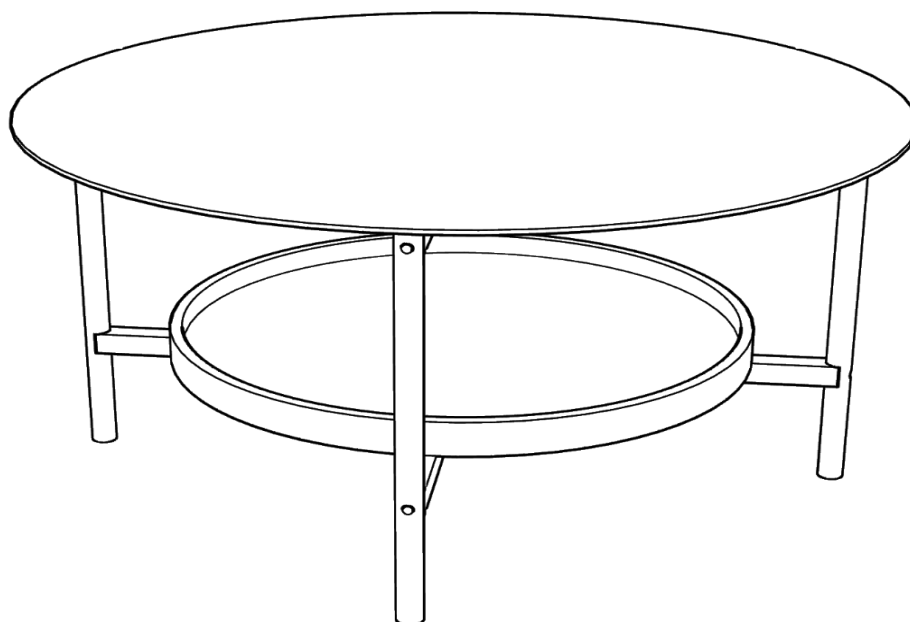

ITEM: **721618**

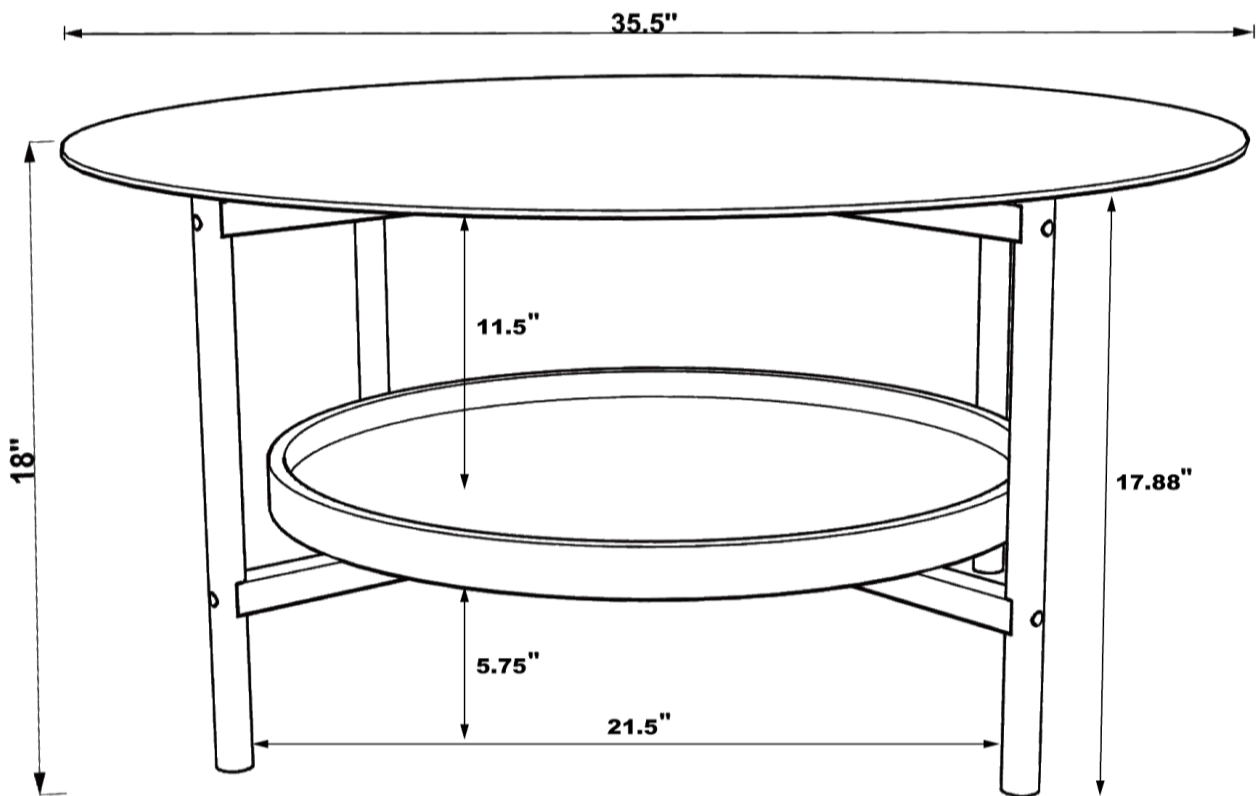

Note : Dimension tolerance $\pm 5\%$