

ASSEMBLY INSTRUCTIONS
COASTER FINE FURNITURE



Fine Furniture for every stage of life

300826(B1&B2)
Daybed

ITEM: 300826 (B1&B2)

ASSEMBLY INSTRUCTIONS

ASSEMBLY TIPS:

1. Remove hardware from box and sort by size.
2. Please check to see that all hardware and parts are present prior to start of assembly.
3. Please follow attached instructions in the same sequence as numbered to assure fast & easy assembly.



WARNING!

1. Don't attempt to repair or modify parts that are broken or defective. Please contact the store immediately.
2. This product is for home use only and not intended for commercial establishments.



ASSEMBLY TIME

35 MINUTES

PARTS IDENTIFICATION

B1 (BOX 1)

A LEFT SIDE PANEL



1PC

B RIGHT SIDE PANEL



1PC

C LEG



4PCS

D ROLL SLAT
(7PCS)



2SETS

E TRUNDLE
SIDE PANEL

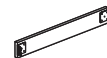

2PCS

F TRUNDLE ROLL
SLAT (5PCS)



2SETS

B2 (BOX 2)

G BACK PANEL

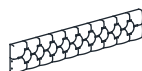

1PC

H FRONT RAIL



1PC

I BACK RAIL



1PC

J TRUNDLE
FRONT PANEL



1PC

K TRUNDLE
BACK PANEL



1PC

L TRUNDLE SLAT



3PCS

M CASTER WITH
SCREW

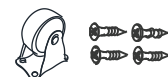

6SETS

NOTE:

Phillips head screw driver is required in the assembly process; however, manufacturer does not provided this item.

ITEM: 300826 (B1&B2)



ASSEMBLY INSTRUCTIONS

ASSEMBLY TIPS:

1. Remove hardware from box and sort by size.
2. Please check to see that all hardware and parts are present prior to start of assembly.
3. Please follow attached instructions in the same sequence as numbered to assure fast & easy assembly.









WARNING!

1. Don't attempt to repair or modify parts that are broken or defective. Please contact the store immediately.
2. This product is for home use only and not intended for commercial establishments.

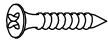
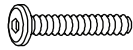
HARDWARE IDENTIFICATION

Z-B2 (BOX 2) - HARDWARE PACK IS LOCATED IN 300826 (B2)

1	SHORT BOLT (M8 x 20MM - RBW)		16PCS	6	SMALL FLAT WASHER (15/64" X 13 Ø - RBW)		12PCS
2	MEDIUM BOLT (M6 x 35MM - RBW)		4PCS	7	FLAT HEAD SCREW (M4 x 32MM - RBW)		16PCS
3	LONG BOLT (M6 x 50MM - RBW)		16PCS	8	SMALL ALLEN WRENCH (M4 x 100MM - BLK)		1PC
4	LOCK WASHER (15/64" x 12 Ø - RBW)		16PCS	9	BIG ALLEN WRENCH (M5 x 65MM - BLK)		1PC
5	BIG FLAT WASHER (15/64" x 19 Ø - RBW)		4PCS				

NOTE:

Phillips head screw driver is required in the assembly process; however, manufacturer does not provided this item.

ITEM: **300826 (B1&B2)**



ASSEMBLY INSTRUCTIONS

STEP 1

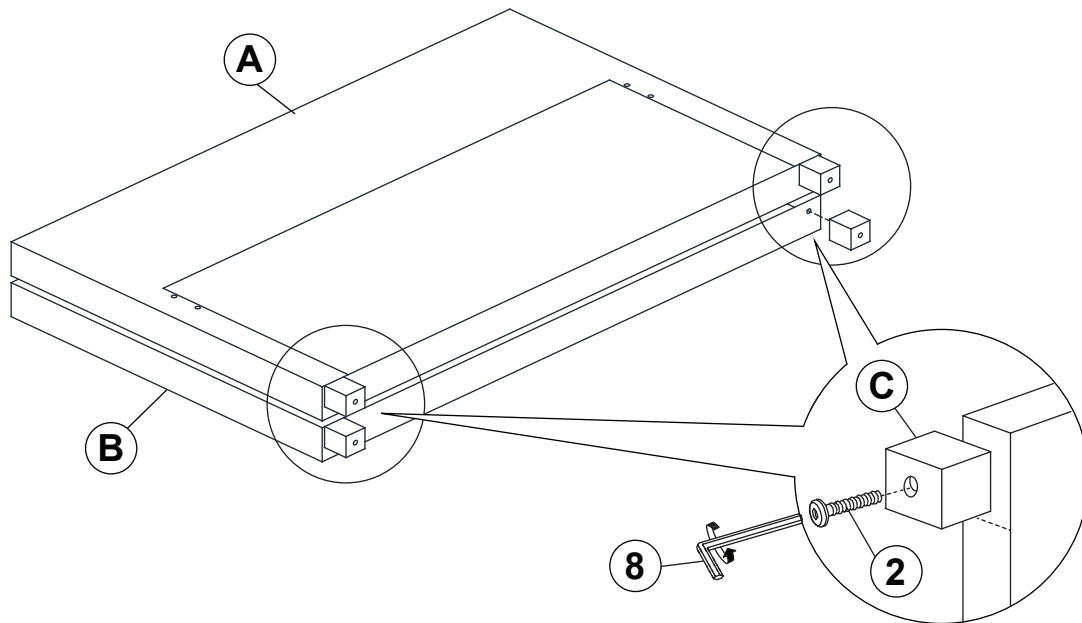

STEP 2

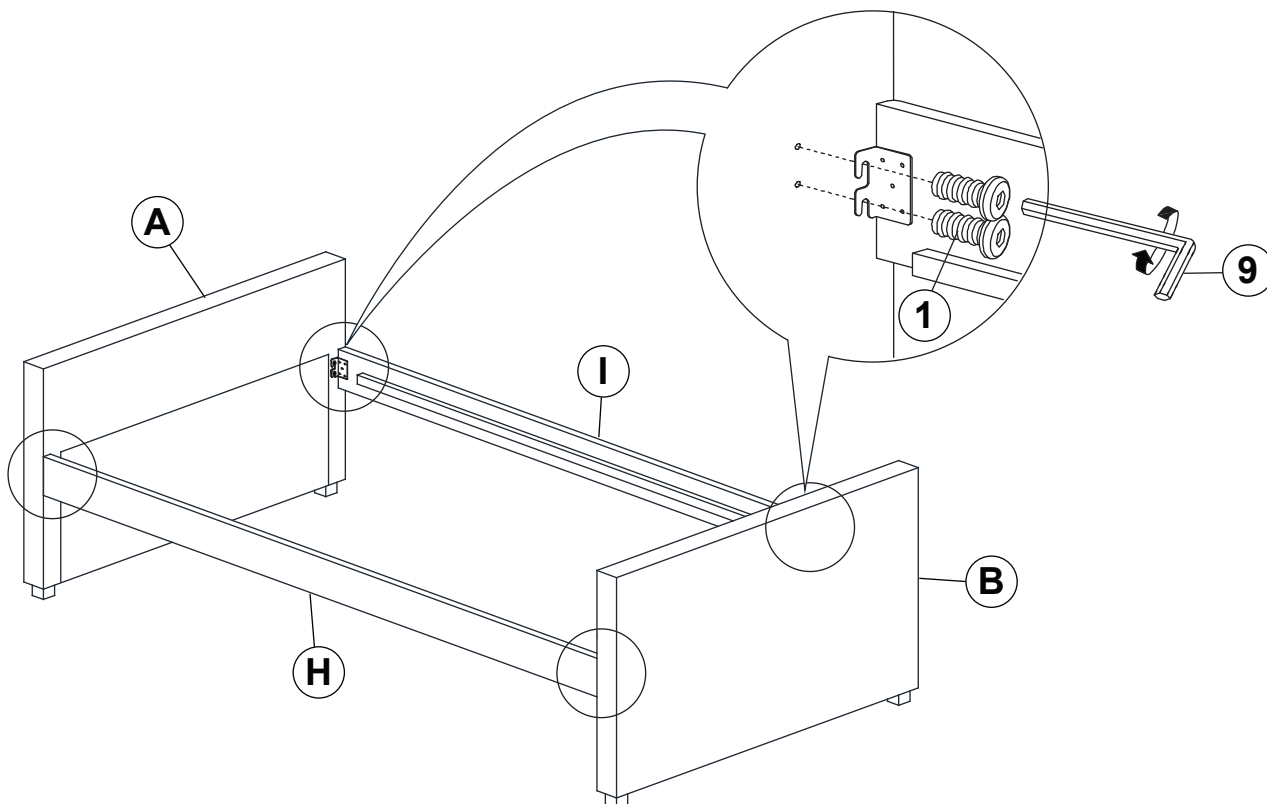

ITEM: **300826 (B1&B2)**



ASSEMBLY INSTRUCTIONS

STEP 3

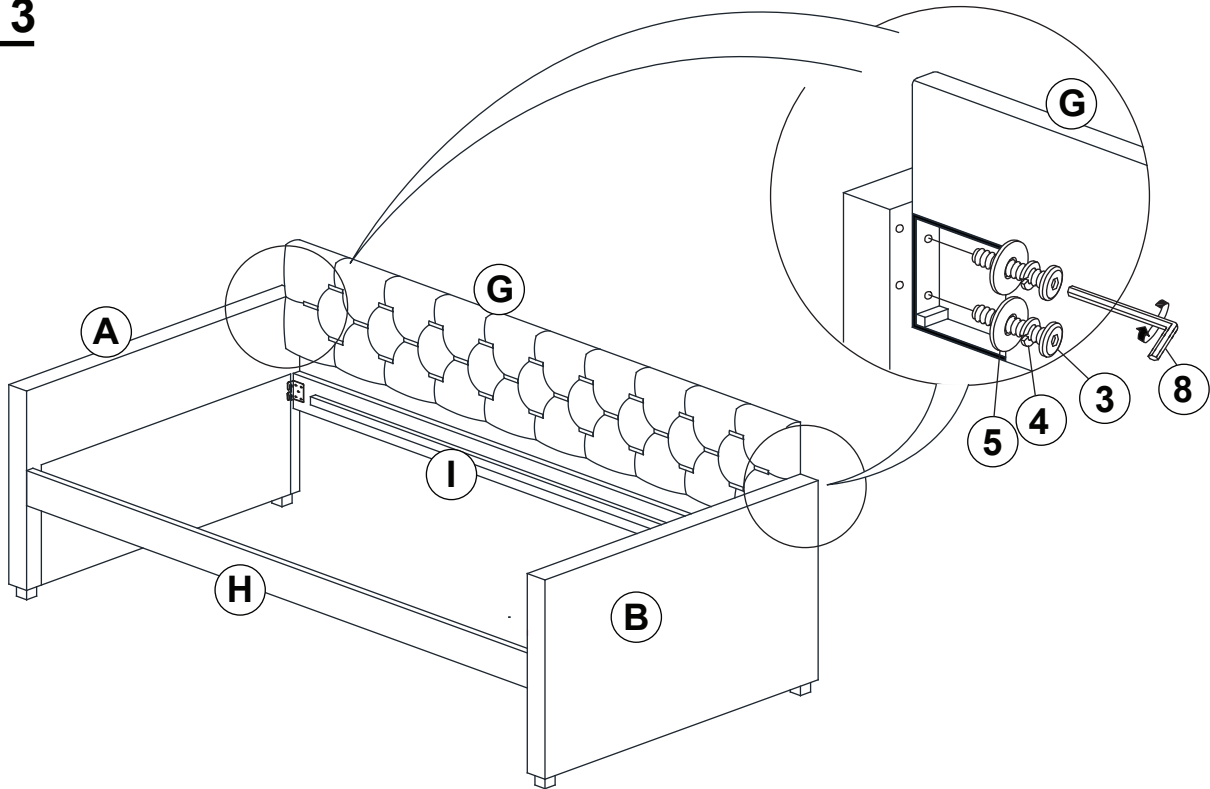

STEP 4

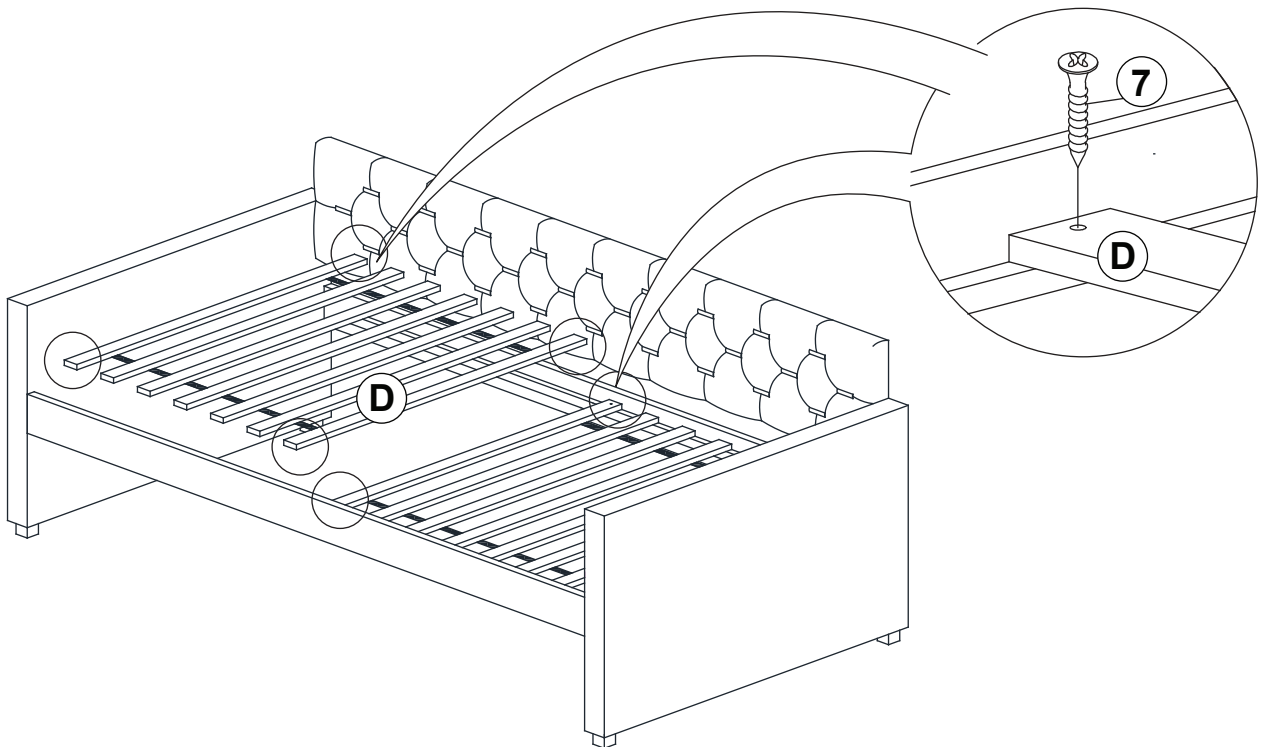

ITEM: **300826 (B1&B2)**



ASSEMBLY INSTRUCTIONS

STEP 5

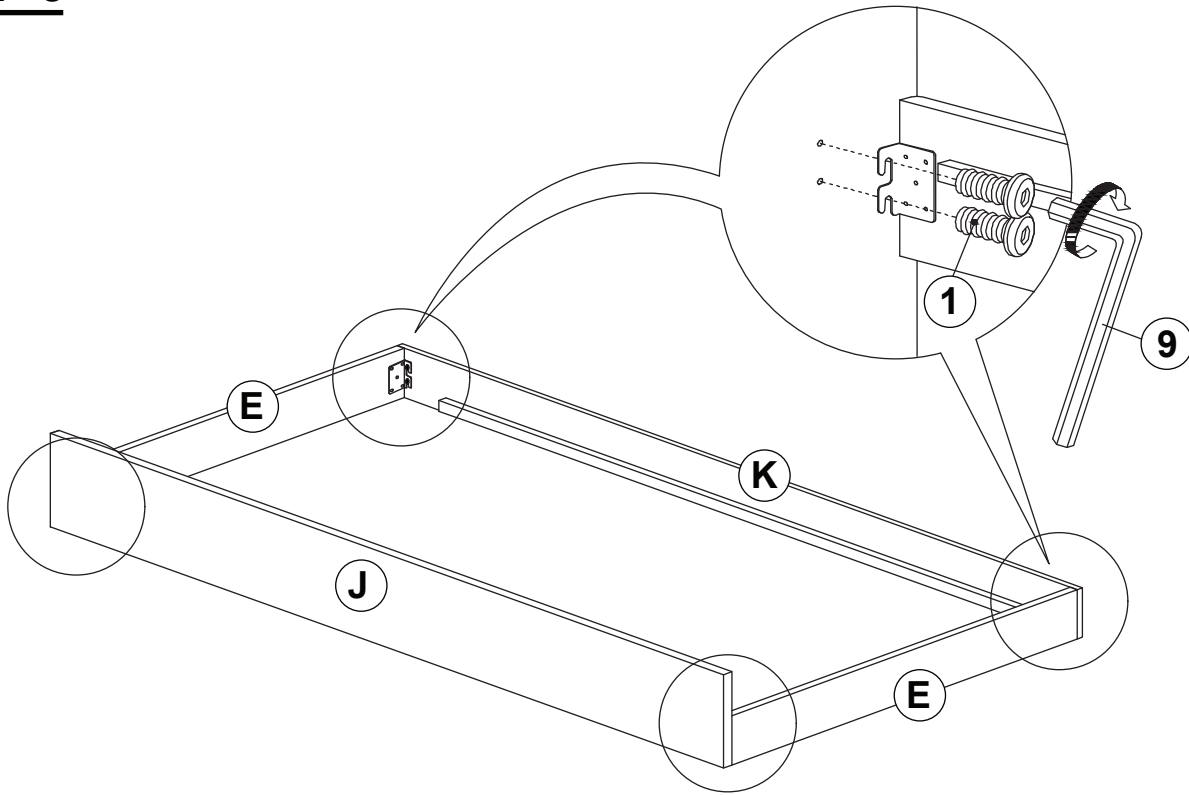

STEP 6

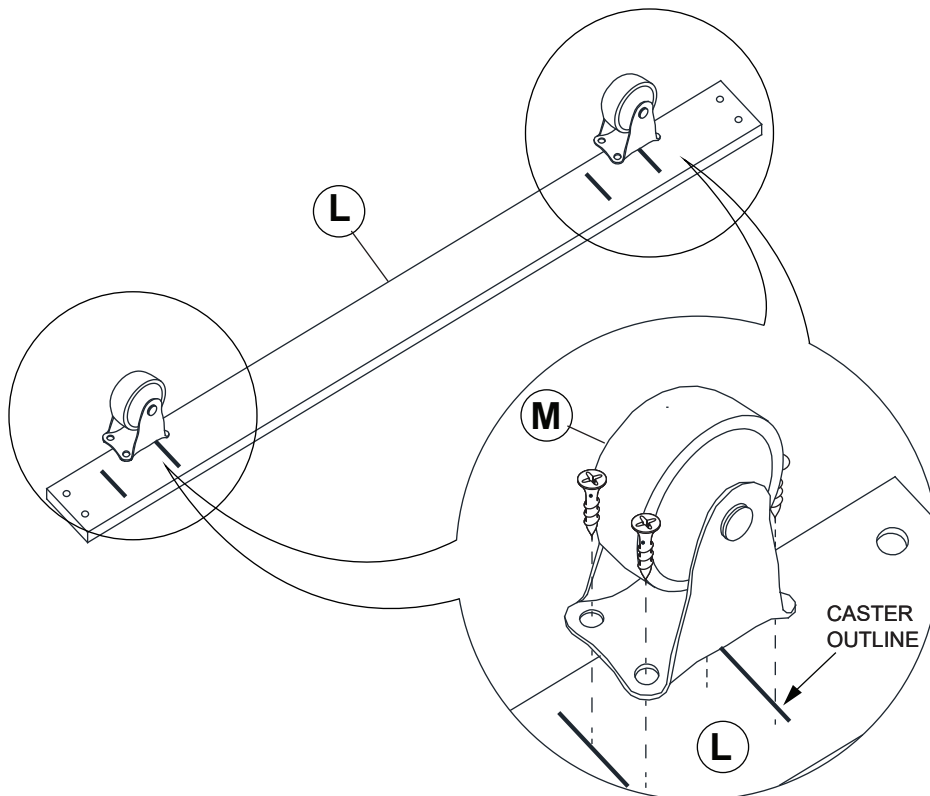

ITEM: **300826 (B1&B2)**

ASSEMBLY INSTRUCTIONS

STEP 7

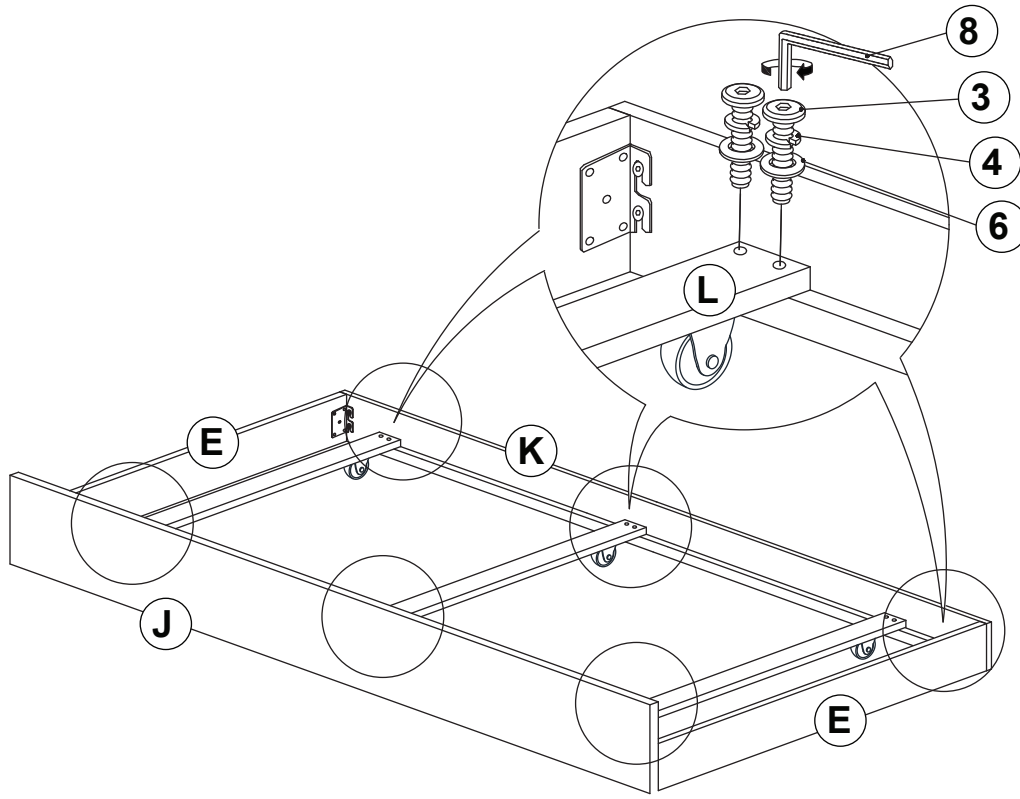

STEP 8

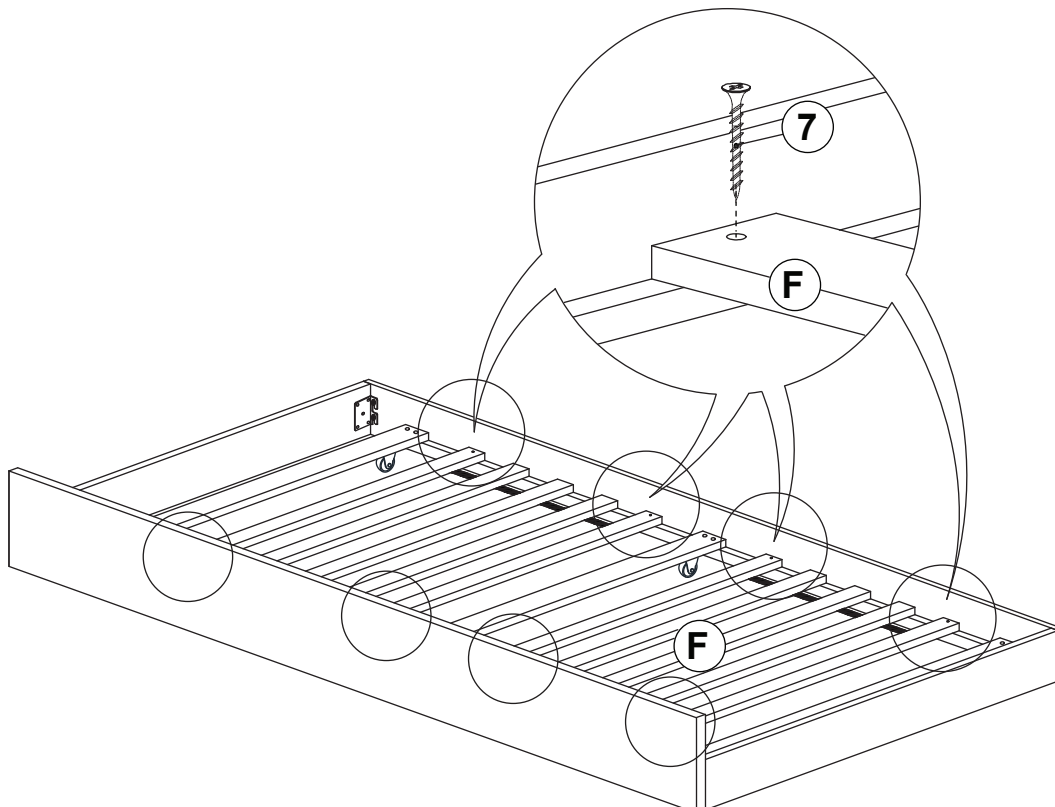

ITEM: **300826 (B1&B2)**



ASSEMBLY INSTRUCTIONS

STEP 9

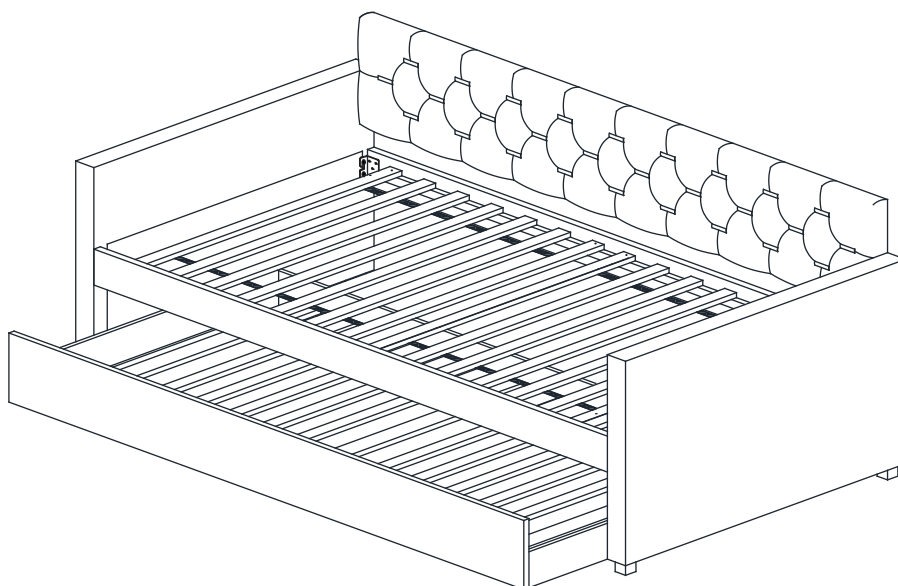

ITEM: 300826 (B1&B2)



Upper Inner Size: 77.25"W X 39.50"D
Trundle Inner Size : 75.50"W X 39.50"D

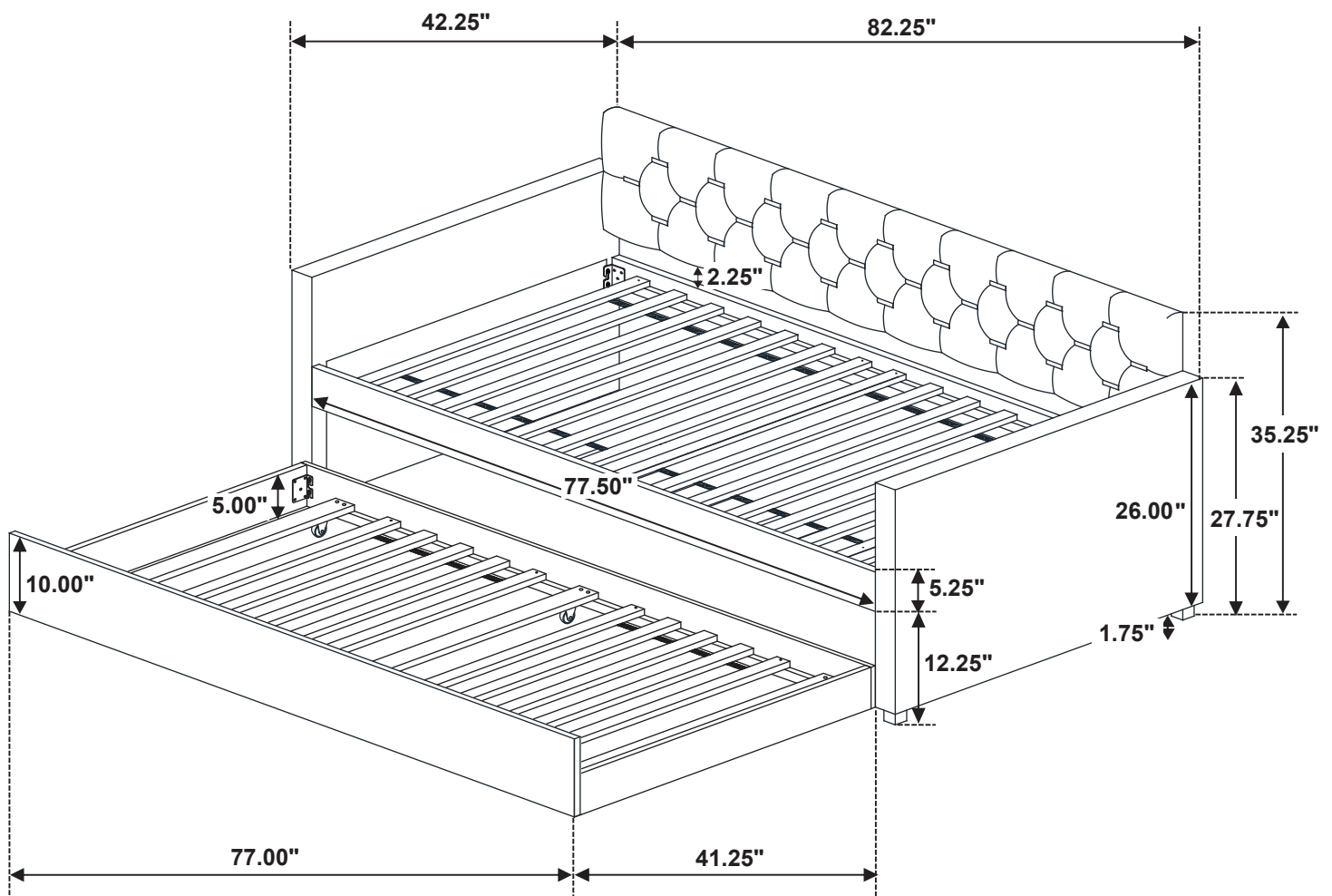

Note : Dimension tolerance $\pm 5\%$