

ASSEMBLY INSTRUCTIONS
COASTER FINE FURNITURE

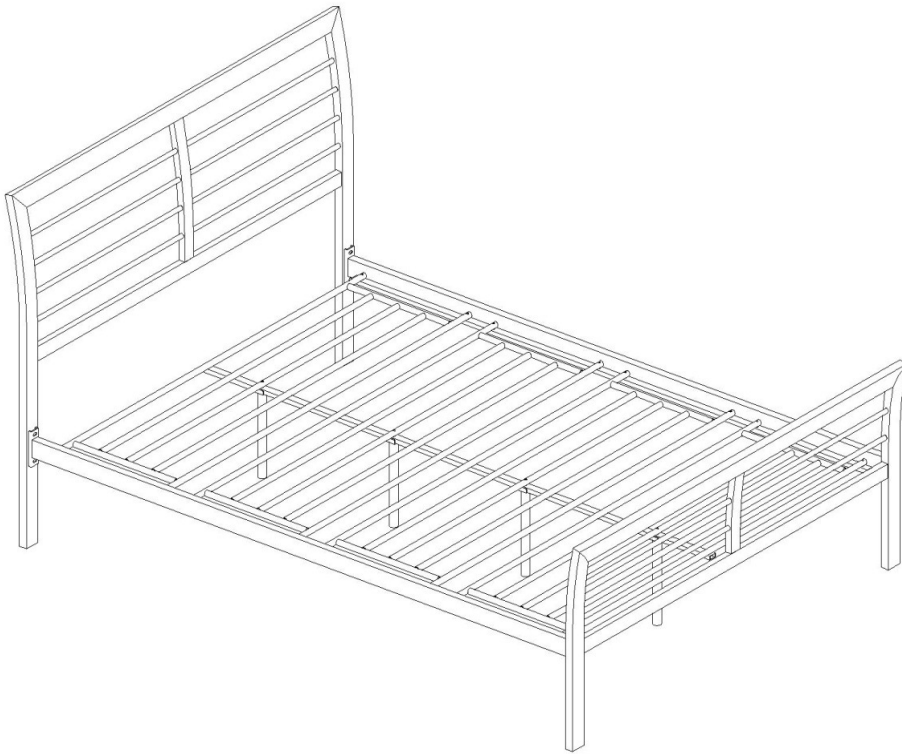

Fine Furniture for every stage of life

300201Q(B1-B2)

Queen Bed

REVISION 0 : 05/30/2019
REVISION 1 : 10/21/2019
REVISION 2 : 09/22/2021
REVISION H:FF/01 /202G
REVISION4 : 03/01/2023
REVISION5 : 03/02/2024

ITEM: 300201Q(B1-B2)



ASSEMBLY INSTRUCTIONS

ASSEMBLY TIPS:

1. Remove hardware from box and sort by size.
2. Please check to see that all hardware and parts are present prior to start of assembly.
3. Please follow attached instructions in the same sequence as numbered to assure fast & easy assembly.



WARNING!

1. Don't attempt to repair or modify parts that are broken or defective. Please contact the store immediately.
2. This product is for home use only and not intended for commercial establishments.



ASSEMBLY TIME

15 MINUTES

PARTS IDENTIFICATION

B1 (BOX 1)

A HEADBOARD



1PC

B FOOTBOARD



1PC

C PLATFORM



4PCS

F SUPPORT LEG



4PCS

B2 (BOX 2)

D SIDE RAIL



2PCS

E PLATFORM SUPPORT



1PC

HARDWARE IDENTIFICATION

Z-B1(BOX1)

HARDWARE PACK IS LOCATED IN 300201QB1

1 BOLT
M6X25mm



8PCS

2 BOLT
M6X38mm



16PCS

3 BOLT
M6X45mm

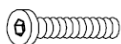

4PCS

4 WASHER
6.5mm



24PCS

5 NUT
M6



16PCS

6 ALLEN KEY
4mm



1PC

7 WRENCH
10mm



1PC

NOTE:

Phillips head screw driver is required in the assembly process; however, manufacturer does not provide this item.

ITEM: **300201Q(B1-B2)**



ASSEMBLY INSTRUCTIONS

STEP 1

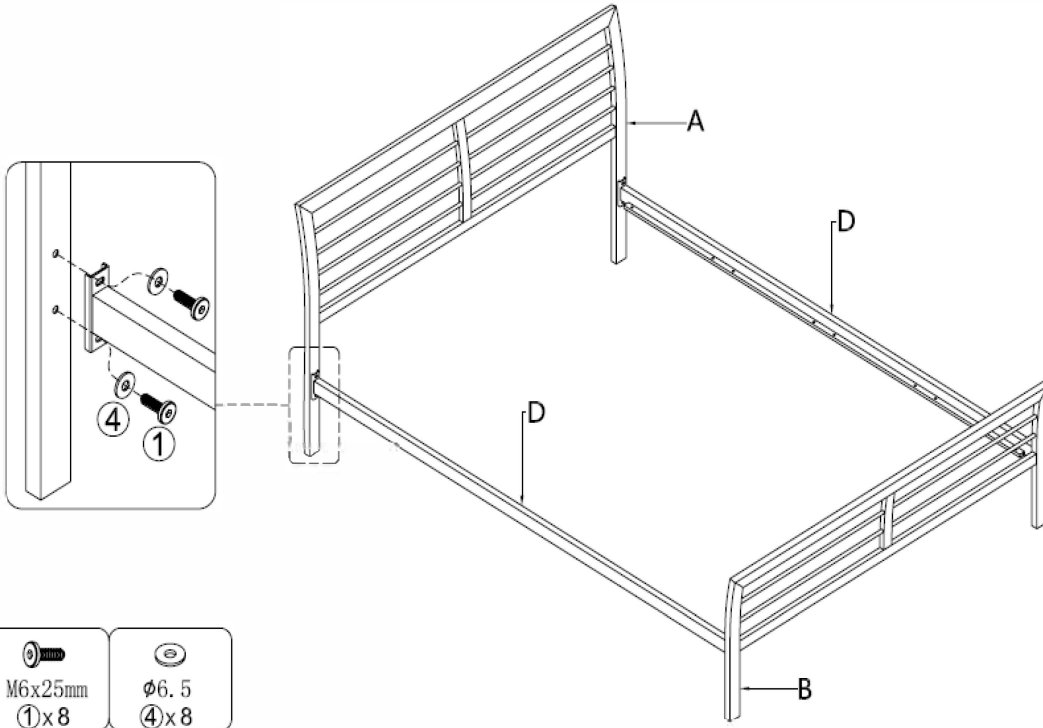

STEP 2

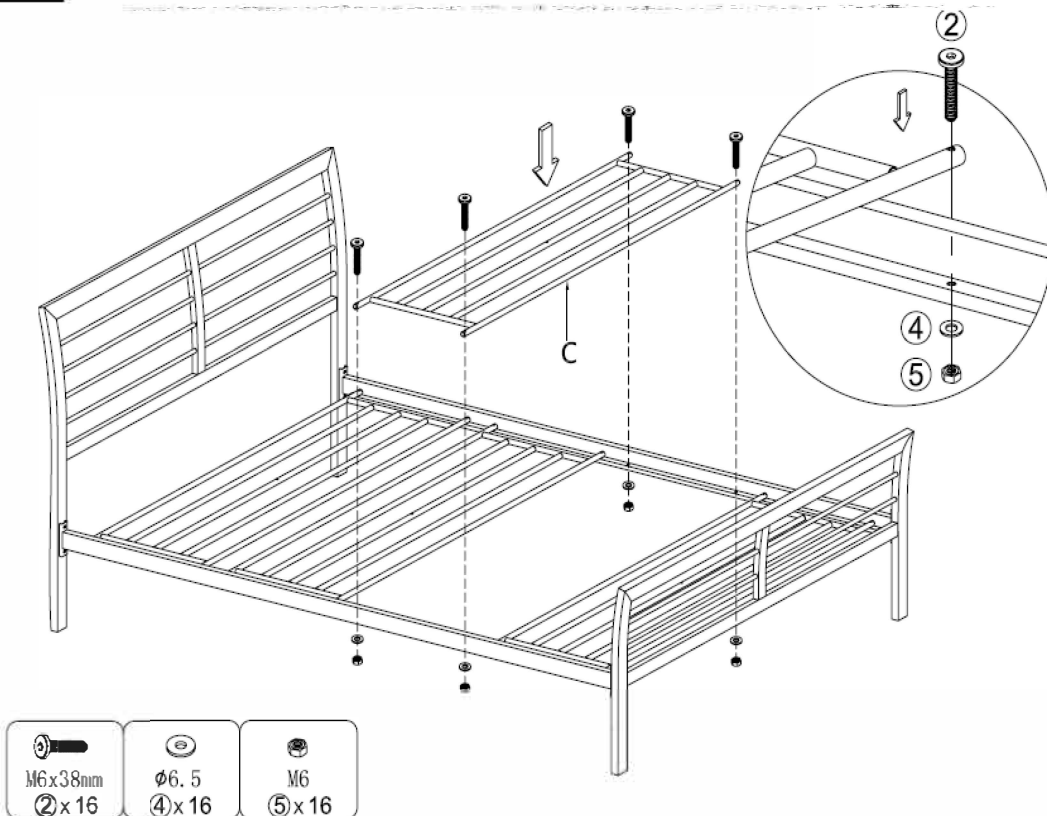

ITEM: **300201Q(B1-B2)**



ASSEMBLY INSTRUCTIONS
STEP 3



ITEM: **300201Q(B1-B2)**

PRODUCT DIMENSION:

