

ASSEMBLY INSTRUCTIONS
COASTER FINE FURNITURE

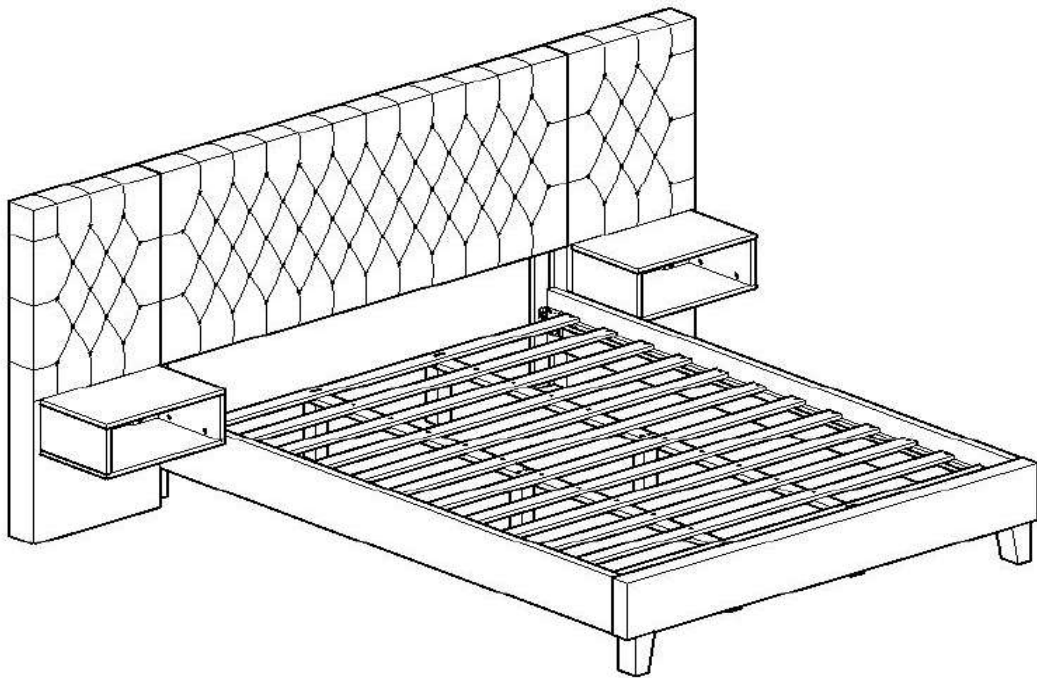

Fine Furniture for every stage of life

300833KE (B1-B3)
Eastern King Bed

ITEM: 300833KE(B1-B3)



ASSEMBLY INSTRUCTIONS

ASSEMBLY TIPS:

1. Remove hardware from box and sort by size.
2. Please check to see that all hardware and parts are present prior to start of assembly.
3. Please follow attached instructions in the same sequence as numbered to assure fast & easy assembly.



WARNING!

1. Don't attempt to repair or modify parts that are broken or defective. Please contact the store immediately.
2. This product is for home use only and not intended for commercial establishments.



ASSEMBLY TIME

35 MINUTES

PARTS IDENTIFICATION

B1 (BOX 1)

| | | | |
|---|---------------------|--|-----|
| A | HEADBOARD PANEL | | 1PC |
| B | LEFT HEADBOARD LEG | | 1PC |
| C | RIGHT HEADBOARD LEG | | 1PC |

| | | | |
|---|----------------------------------|--|------|
| D | CENTER RAIL SUPPORT WITH LEVELER | | 6PCS |
| E | FOOTBOARD LEG | | 2PCS |

B2 (BOX 2)

| | | | |
|---|-------------------------------|--|------|
| F | LEFT PANEL | | 1PC |
| G | RIGHT PANEL | | 1PC |
| H | NIGHTSTAND TOP & BOTTOM PANEL | | 4PCS |

| | | | |
|---|-----------------------|--|------|
| I | NIGHTSTAND SIDE PANEL | | 4PCS |
| J | NIGHTSTAND BACK PANEL | | 4PCS |

B3 (BOX 3)

| | | | |
|---|-----------------|--|------|
| K | BED RAIL | | 2PCS |
| L | FOOTBOARD PANEL | | 1PC |

| | | | |
|---|------------------|--|-------|
| M | CENTER RAIL | | 2PCS |
| N | ROLL SLAT (6PCS) | | 2SETS |

ITEM:300833KE(B1-B3)



ASSEMBLY INSTRUCTIONS

ASSEMBLY TIPS:

1. Remove hardware from box and sort by size.
2. Please check to see that all hardware and parts are present prior to start of assembly.
3. Please follow attached instructions in the same sequence as numbered to assure fast & easy assembly.

















WARNING!

1. Don't attempt to repair or modify parts that are broken or defective. Please contact the store immediately.
2. This product is for home use only and not intended for commercial establishments.

HARDWARE IDENTIFICATION

Z-B1 (BOX 1) - HARDWARE PACK IS LOCATED IN 300833KE (B1)

| | | | | | | | |
|---|--|---|-------|----|---|---|-------|
| 1 | SMALL ALLEN WRENCH (M4 x 55mm - BLK) |  | 1PC | 9 | FLAT WASHER (M6 - RBW) |  | 18PCS |
| 2 | BIG ALLEN WRENCH (M5 x 100mm - BLK) |  | 1PC | 10 | FLAT HEAD SCREW (M4 x 25mm - RBW) |  | 44PCS |
| 3 | BOLT 1 (M8 x 80mm - RBW) |  | 2PCS | 11 | WOOD DOWEL (M8 x 25mm - NATURAL) |  | 32PCS |
| 4 | BOLT 2 (M6 x 35mm - RBW) |  | 12PCS | 12 | CAM NUT |  | 28PCS |
| 5 | BOLT 3 (M6 x 40mm - RBW) |  | 10PCS | 13 | CAM BOLT |  | 28PCS |
| 6 | BOLT 4 (M6 x 60mm - RBW) |  | 8PCS | 14 | DECORATIVE STICKER |  | 36PCS |
| 7 | BOLT 5 (M6 x 50mm - RBW) |  | 8PCS | | | | |
| 8 | LOCK WASHER (M6 - RBW) |  | 18PCS | | | | |

NOTE:

Phillips head screw driver is required in the assembly process; however, manufacturer does not provide this item.

ASSEMBLY INSTRUCTIONS

STEP 1

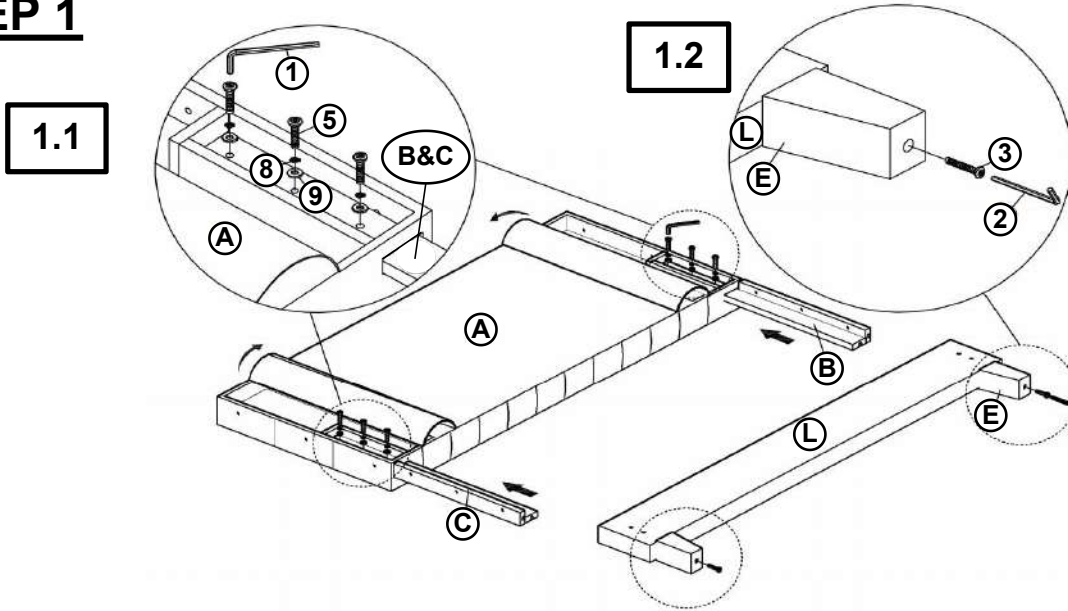

STEP 2

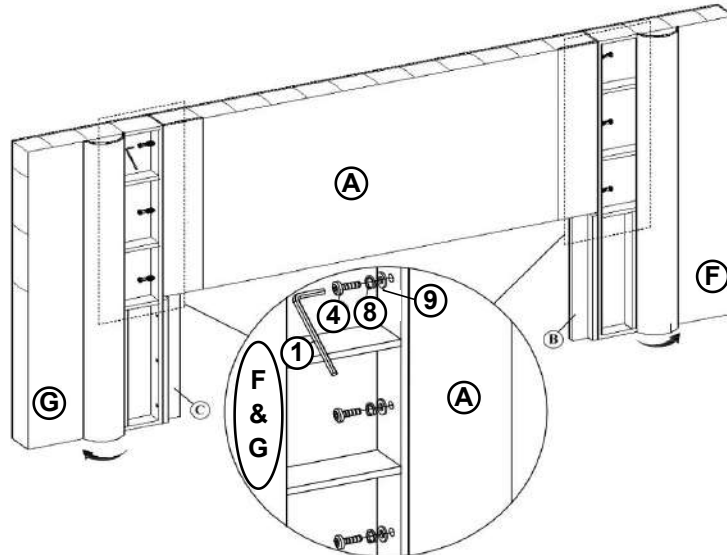

STEP 3

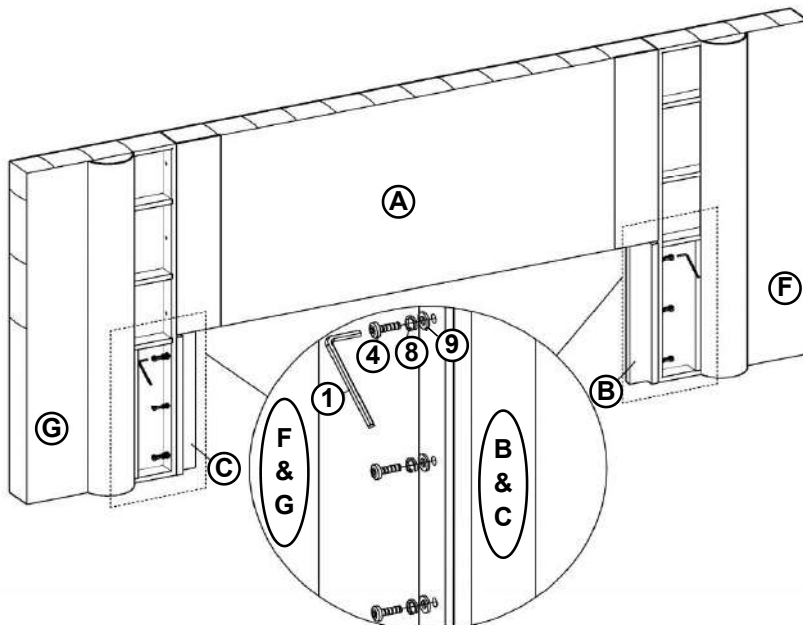

ITEM: **300833KE(B1-B3)**



ASSEMBLY INSTRUCTIONS

STEP 4

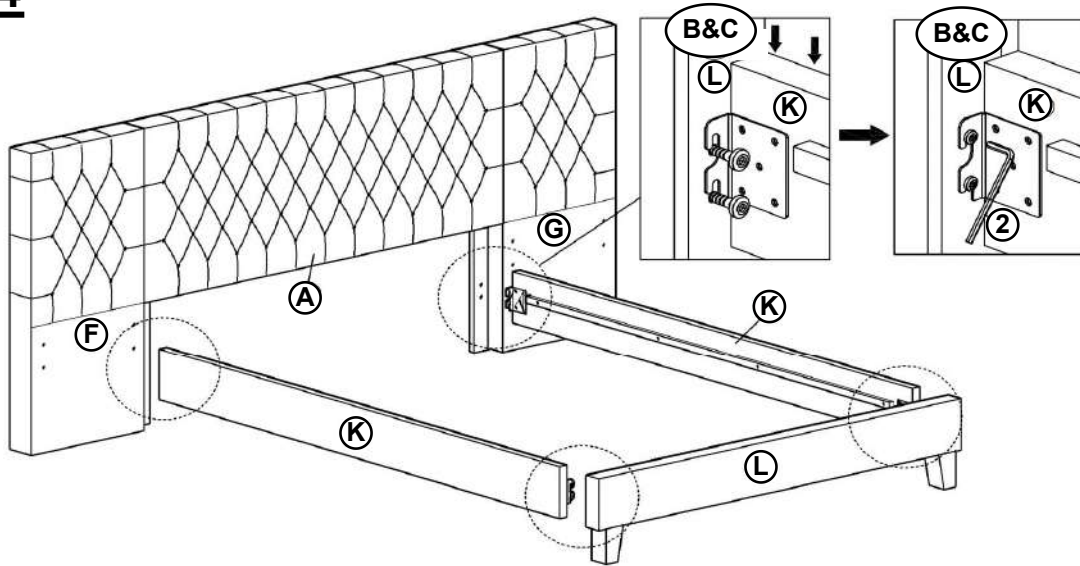

STEP 5

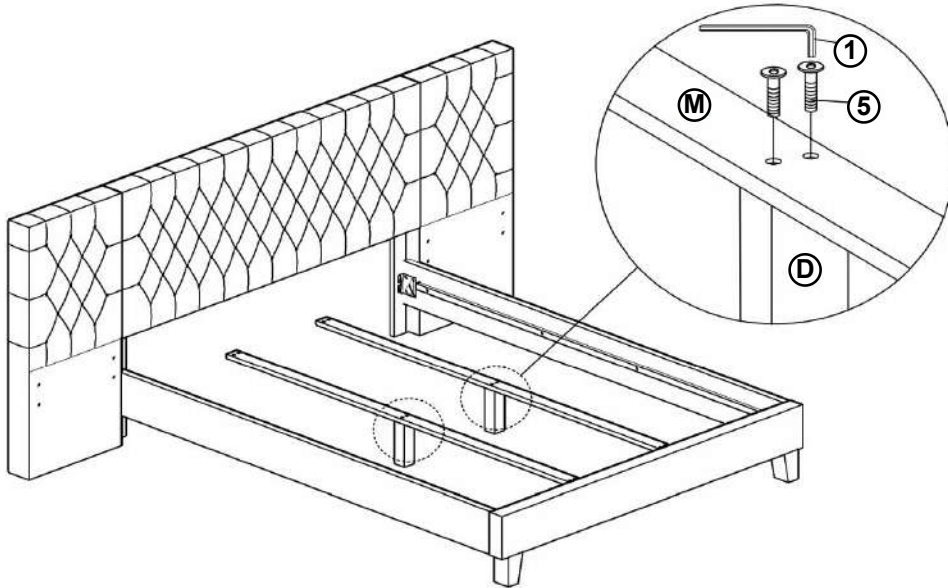

STEP 6

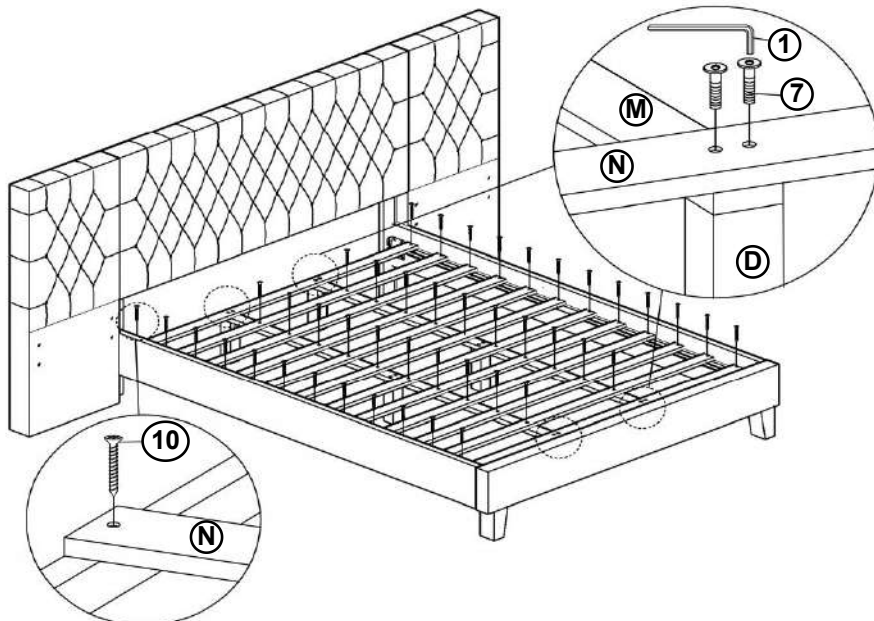

ASSEMBLY INSTRUCTIONS
STEP 7

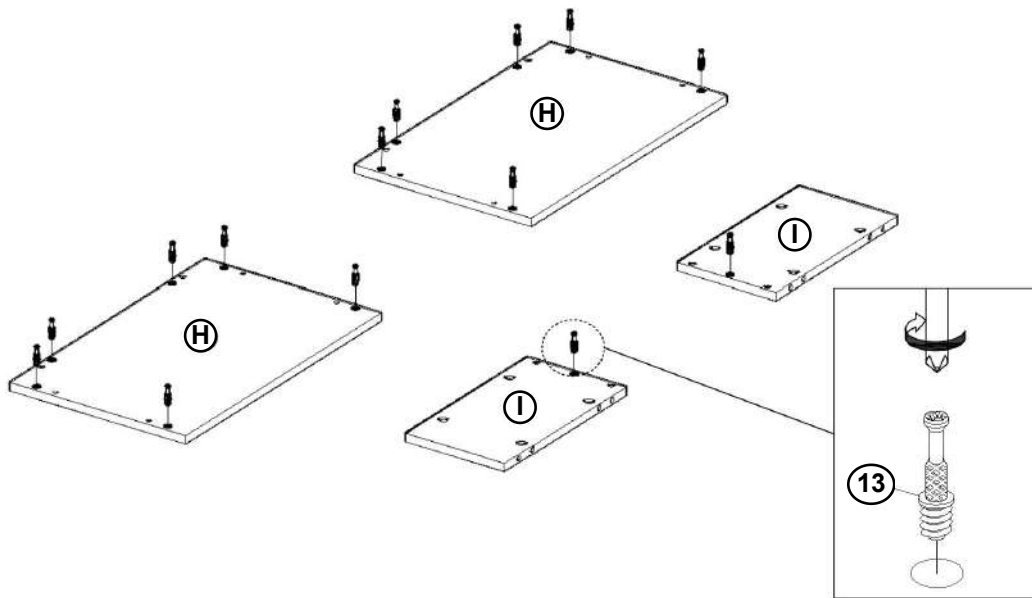

STEP 8

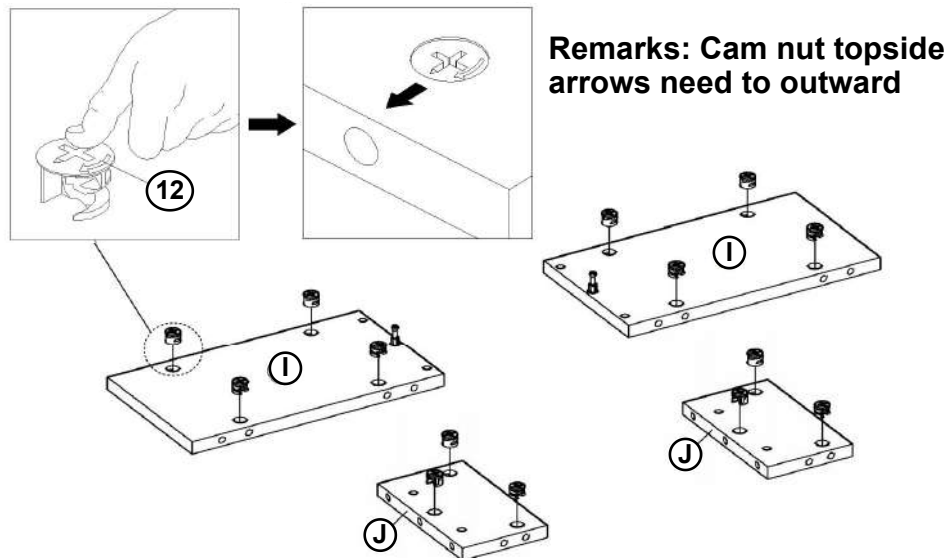

STEP 9

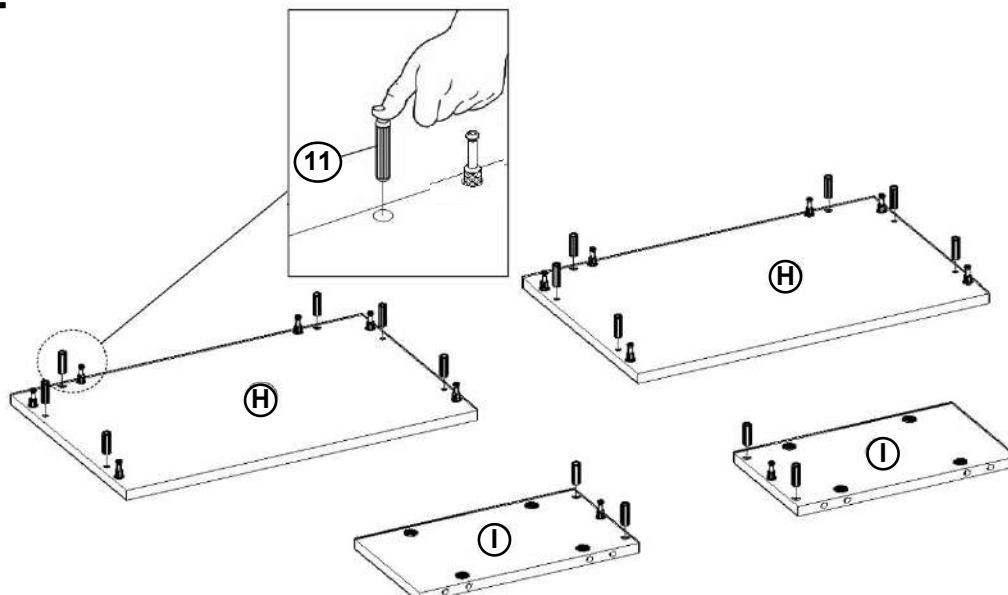

ASSEMBLY INSTRUCTIONS
STEP 10

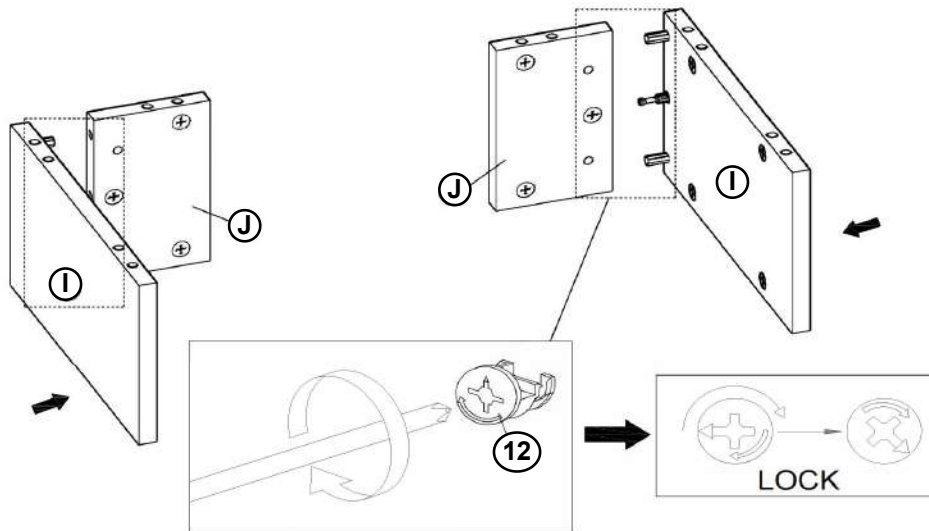

STEP 11

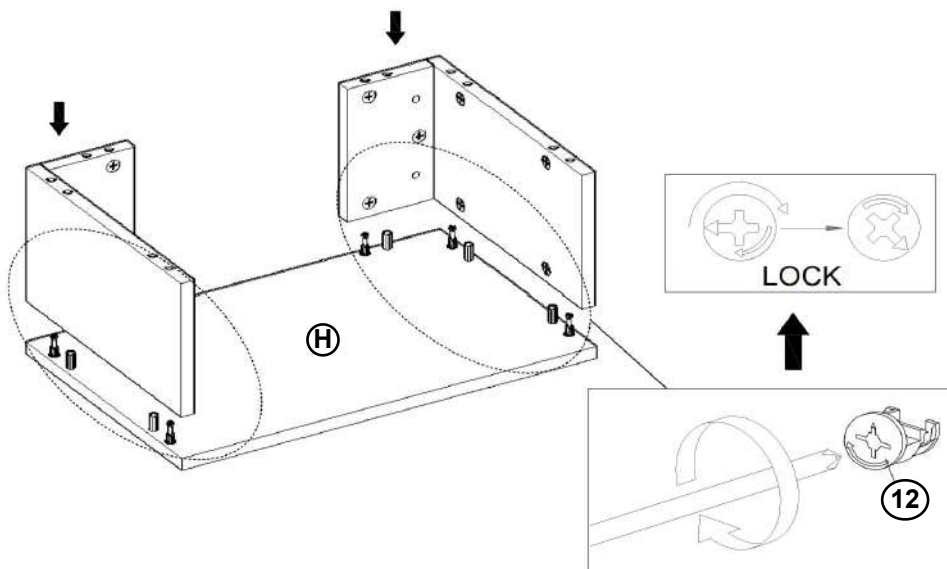

STEP 12

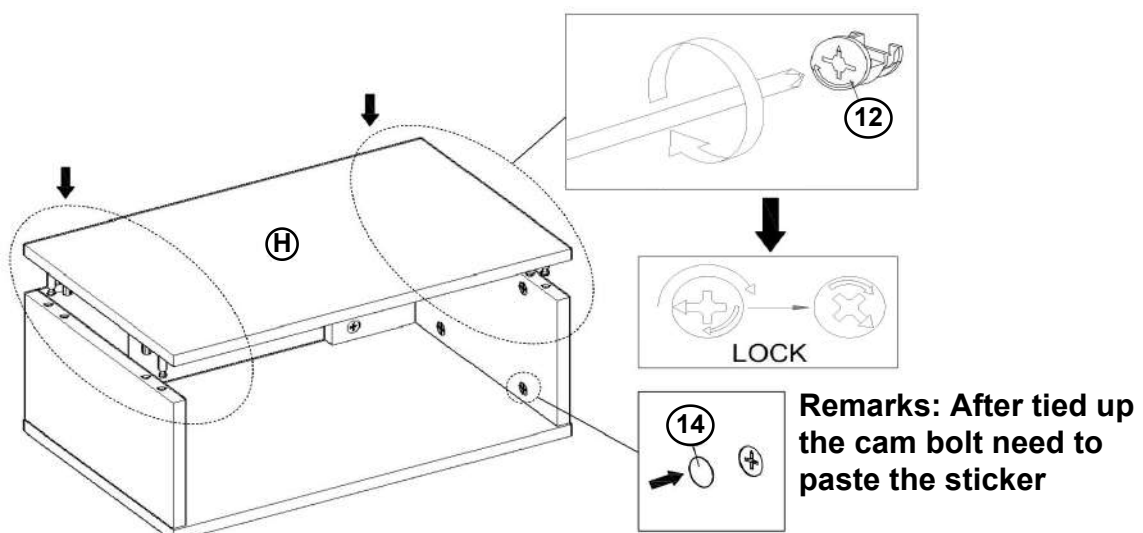

ITEM: **300833KE(B1-B3)**



ASSEMBLY INSTRUCTIONS

STEP 13

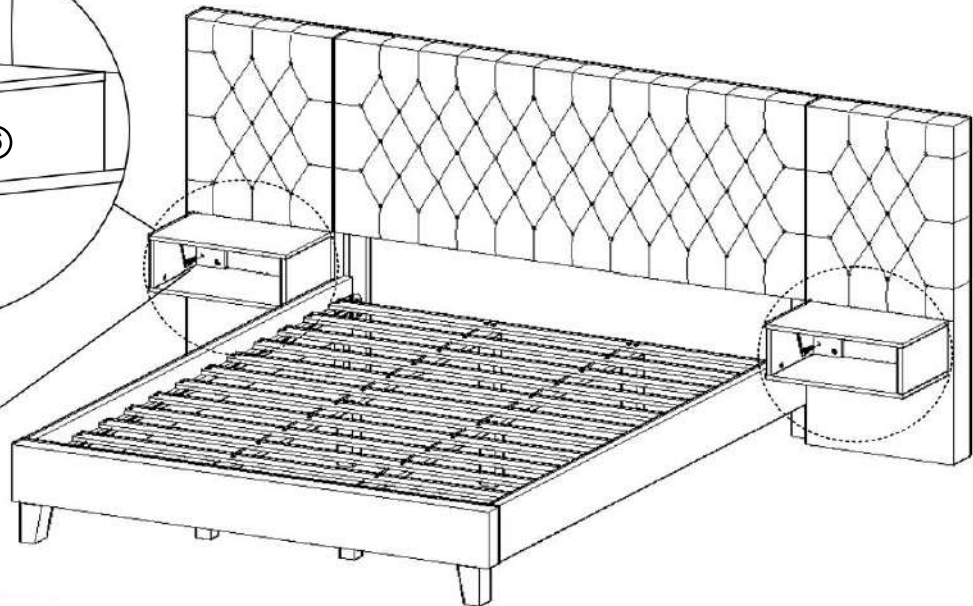
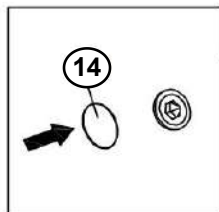
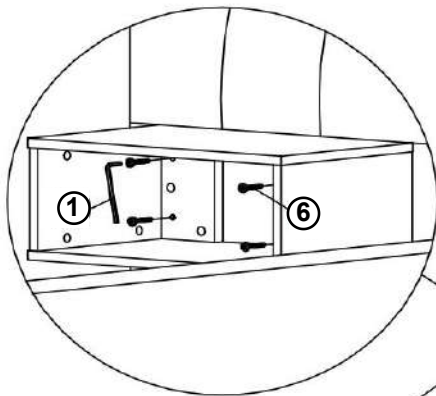

Remarks: After tied up the bolts need to paste the sticker

STEP 14
COMPLETE

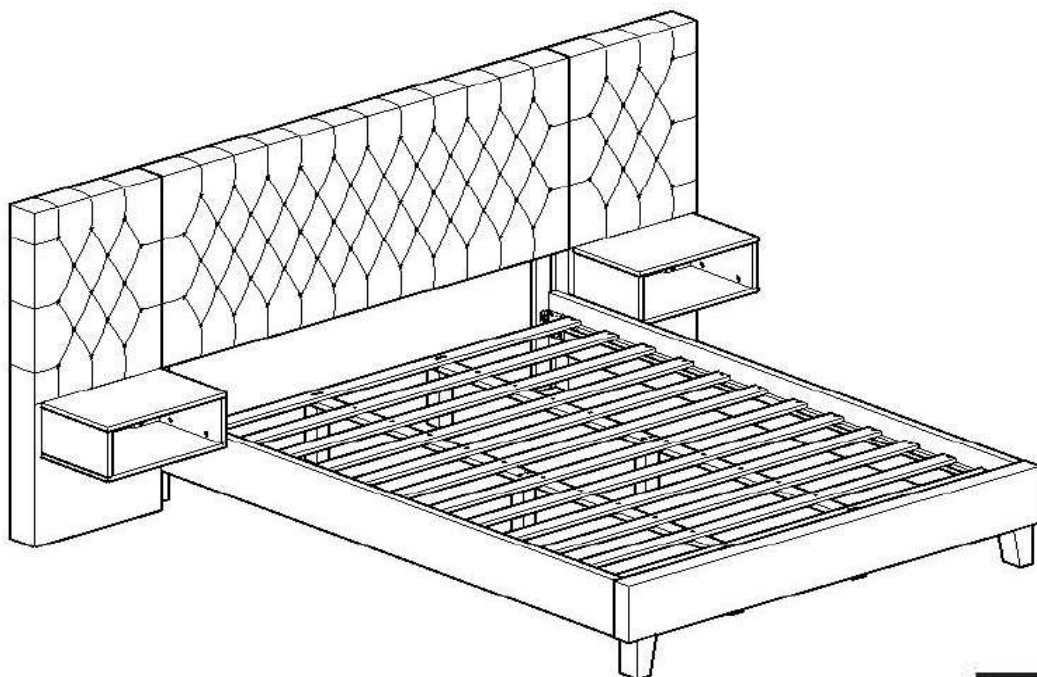

ITEM:300833KE(B1-B3)



Inner Size : 76.75"W X 81.25"D

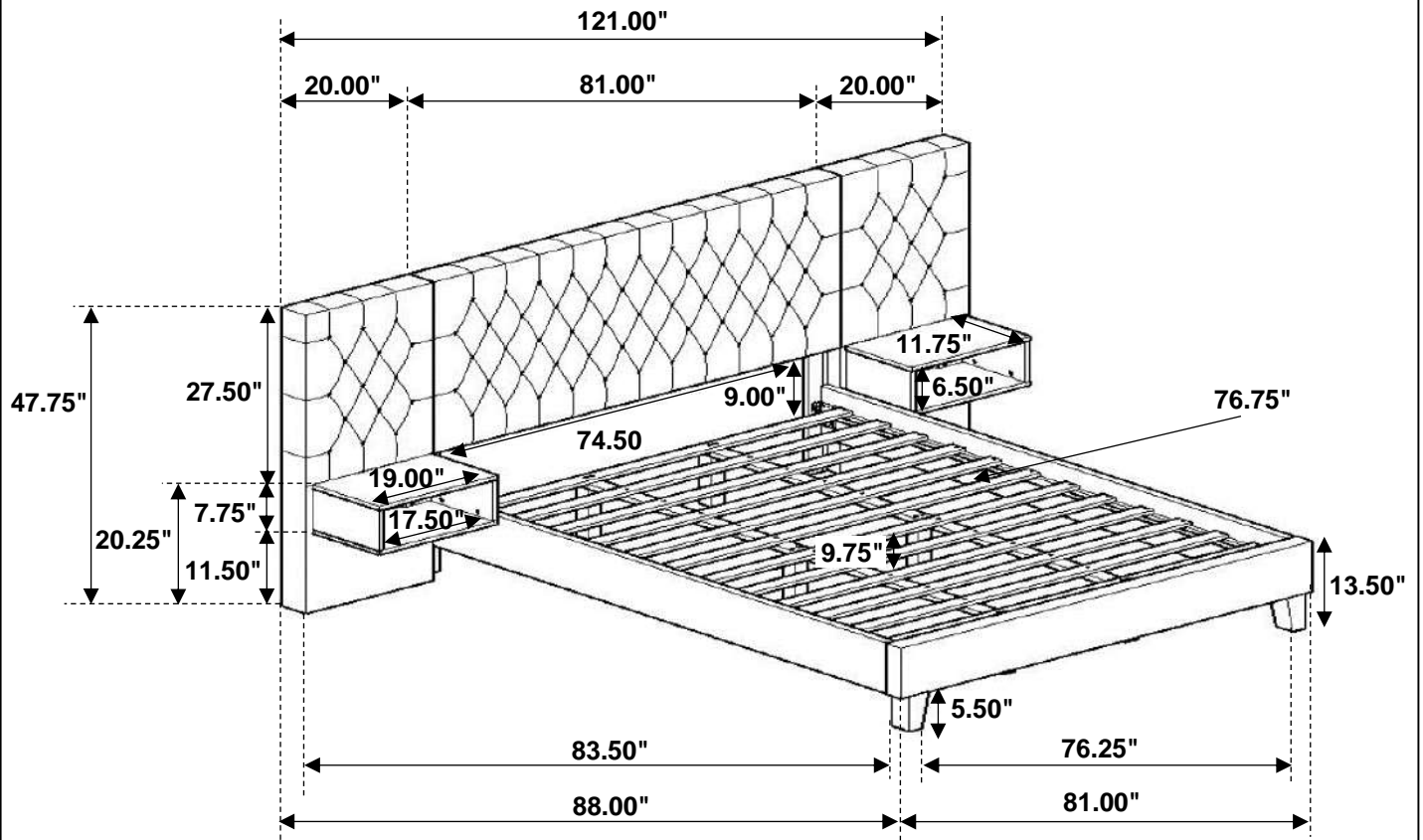

Note : Dimension tolerance $\pm 5\%$