

*ASSEMBLY INSTRUCTIONS*  
*COASTER FINE FURNITURE*



*Fine Furniture for every stage of life*

**120715**  
**BAR TABLE**

REVISION 0 : 09/04/2017  
REVISION 1 : 09/06/2022

ITEM:120715



# ASSEMBLY INSTRUCTIONS

## ASSEMBLY TIPS:

1. Remove hardware from box and sort by size.
2. Please check to see that all hardware and parts are present prior to start of assembly.
3. Please follow attached instructions in the same sequence as numbered to assure fast & easy assembly.



### WARNING!

1. Don't attempt to repair or modify parts that are broken or defective. Please contact the store immediately.
2. This product is for home use only and not intended for commercial establishments.

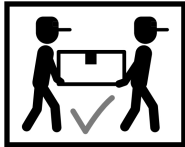

ASSEMBLY TIME 45 MINUTES

## PARTS IDENTIFICATION

A	TOP GLASS		1PC
B	BASE		1PC
C	BOTTOM SHELF		1PC
D	TOP SHELF		1PC
E	STEEL GUARD		1PC
F	TOP POST		1PC

# ITEM:120715 ASSEMBLY INSTRUCTIONS







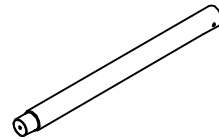



G

BOTTOM POST



1PC

## HARDWARE IDENTIFICATION

1	LARGE ALLEN KEY (5/16" x 50mm SR)		1PC
2	SPRING WASHER (5/16")		1PC
3	HEXAGONAL (1/4")		1PC
4	NUT (1/4")		2PCS
5	MEDIUM ALLEN BOLT (1/4" x 63mm SR)		2PCS
6	SMALL ALLEN BOLT (1/4" x 12mm SR)		3PCS
7	WASHER (5/16" x 57mm)		1PC
8	ALLEN WRENCH (4mm,5mm)		1PC

# ITEM:120715 ASSEMBLY INSTRUCTIONS



**STEP 1** Do not tighten until each step is completed or instructed.

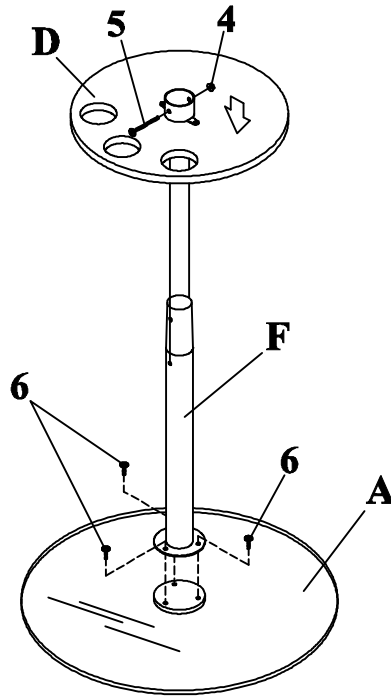

## **STEP 2**

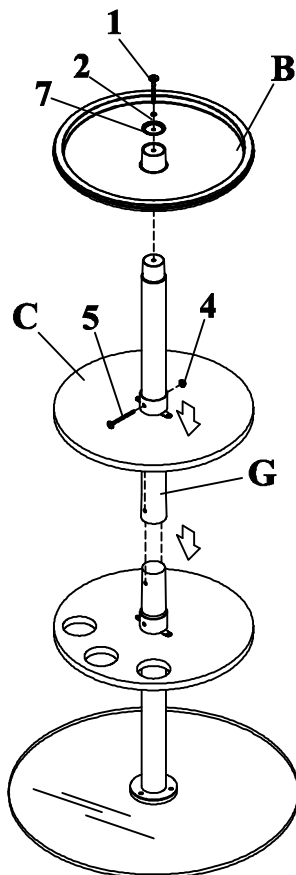

ITEM:120715  
ASSEMBLY INSTRUCTIONS  
STEP 3

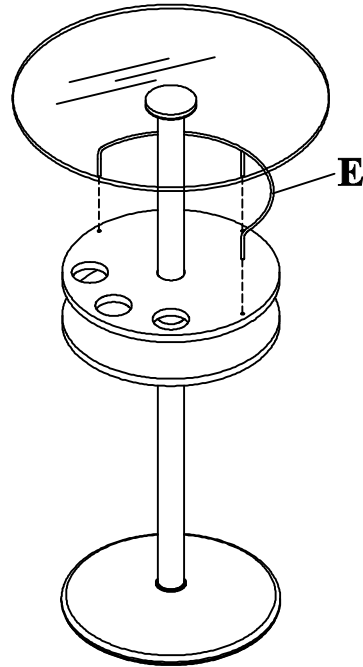

STEP 4  
COMPLETE

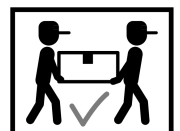
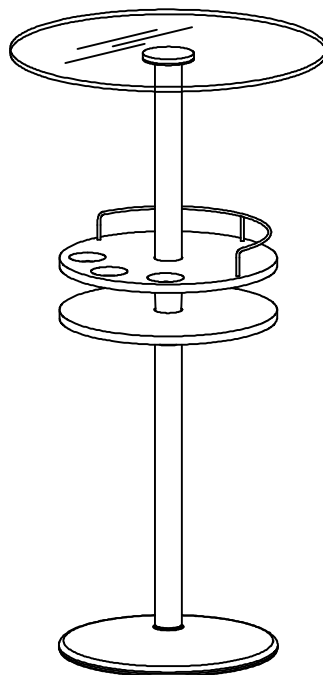

# ITEM:120715 ASSEMBLY INSTRUCTIONS



<b>Product Size : 597 DIA X 1117H (MM)</b>
<b>Product Size : 23.5" DIA X 44"</b>

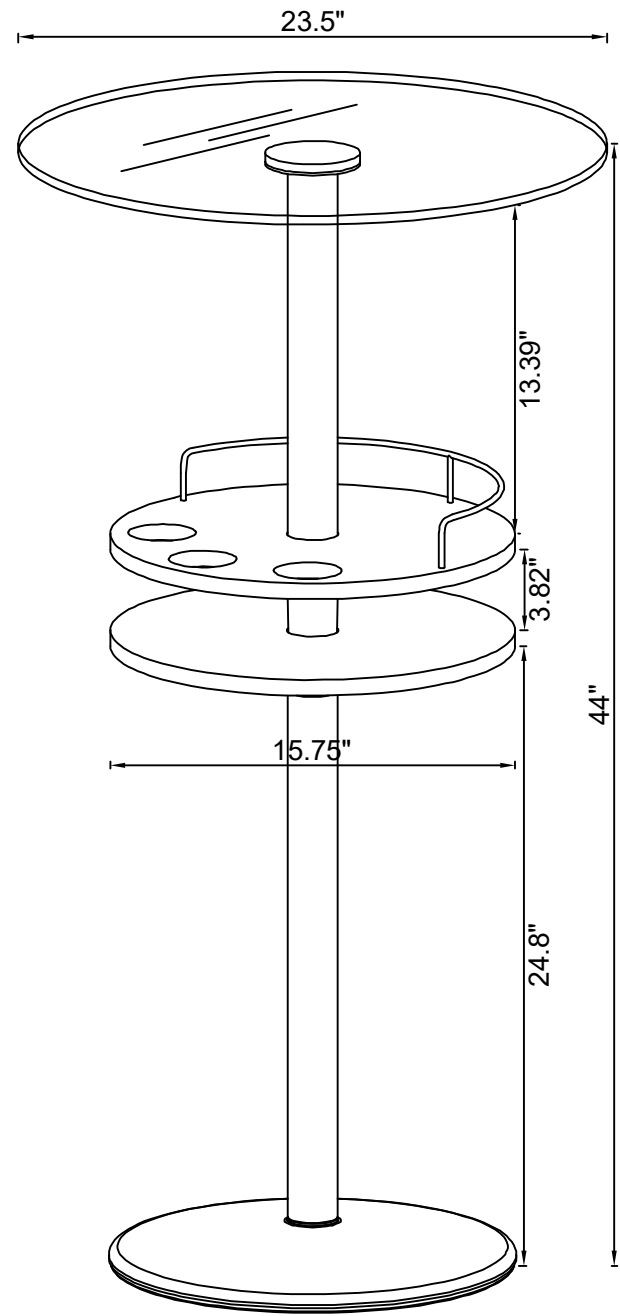

Note : Dimension tolerance  $\pm 5\%$