

ASSEMBLY INSTRUCTIONS
COASTER FINE FURNITURE

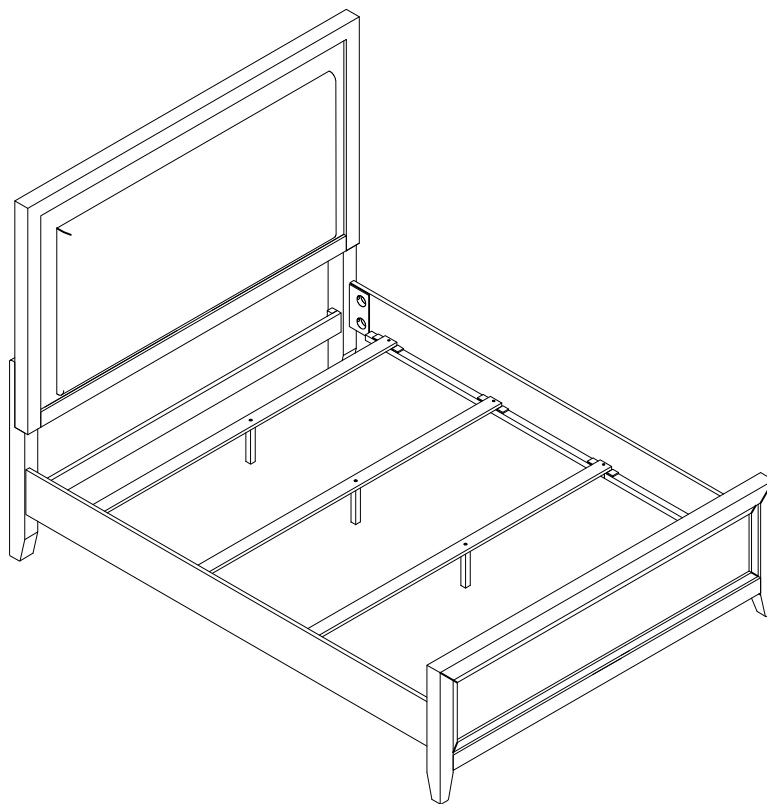

Fine Furniture for every stage of life

224841Q(B1-B3)
Queen Bed

ITEM: 224841Q(B1-B3)



ASSEMBLY INSTRUCTIONS

ASSEMBLY TIPS:

1. Remove hardware from box and sort by size.
2. Please check to see that all hardware and parts are present prior to start of assembly.
3. Please follow attached instructions in the same sequence as numbered to assure fast & easy assembly.



WARNING!

1. Don't attempt to repair or modify parts that are broken or defective. Please contact the store immediately.
2. This product is for home use only and not intended for commercial establishments.







ASSEMBLY TIME

25 MINUTES

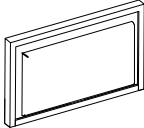
PARTS IDENTIFICATION



B1 (BOX 1)

A	HEADBOARD PANEL		1PC	B	LEFT HEADBOARD LEG		1PC
C	RIGHT HEADBOARD LEG		1PC	D	HEADBOARD BOTTOM RAIL		1PC

B2 (BOX 2)

E	FOOTBOARD		1PC
---	-----------	---	-----

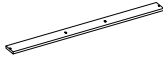
B3 (BOX 3)

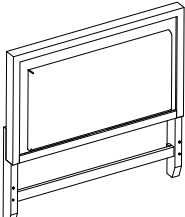
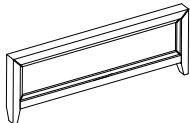
F	BED RAIL		2PCS	G	BED SLAT		4PCS
H	BED SLAT SUPPORT WITH LEVELER		4PCS				
HB	224841Q(B1) FROM BOX 1 HEADBOARD COMPLETE		1PC	E	224841Q(B2) FROM BOX 2 FOOTBOARD		1PC

ITEM: 224841Q(B1-B3)



ASSEMBLY INSTRUCTIONS

ASSEMBLY TIPS:

1. Remove hardware from box and sort by size.
2. Please check to see that all hardware and parts are present prior to start of assembly.
3. Please follow attached instructions in the same sequence as numbered to assure fast & easy assembly.









WARNING!





1. Don't attempt to repair or modify parts that are broken or defective. Please contact the store immediately.
2. This product is for home use only and not intended for commercial establishments.

HARDWARE IDENTIFICATION

Z-B1 (BOX 1) - HARDWARE PACK IS LOCATED IN 224841Q(B1)

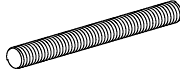
1	SHORT BOLT (Ø1/4" x 38MM - BLK)		2PCS
2	SMALL LOCK WASHER (Ø1/4" x 10 x 2MM - BLK)		2PCS
3	SMALL FLAT WASHER (Ø1/4" x 19 x 2MM - BLK)		2PCS
4	LONG BOLT (Ø5/16" x 45MM - BLK)		6PCS
5	BIG LOCK WASHER (Ø5/16" x 12 x 2MM - BLK)		6PCS
6	BIG FLAT WASHER (Ø5/16" x 19 x 2MM - BLK)		6PCS
7	ALLEN WRENCH (M4 x 58MM - BLK)		1PC

Z-B2 (BOX 2) - HARDWARE PACK IS LOCATED IN 224841Q(B2)

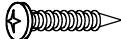
8	THREADED BOLT (Ø5/16" x 90MM - BLK)		8PCS
9	NYLON WASHER (26 x 12 x 8MM - BLK)		8PCS
10	HEX NUT (Ø5/16 x 6MM - BLK)		8PCS
11	WRENCH (12MM - BLK)		1PC
12	PAN HEAD SCREW (Ø8 x 25MM - BLK)		8PCS

NOTE:

Philips head screw driver is required in the assembly process; however, manufacturer does not provide this item.

ITEM: 224841Q (B1-B3)

ASSEMBLY INSTRUCTIONS

STEP 1

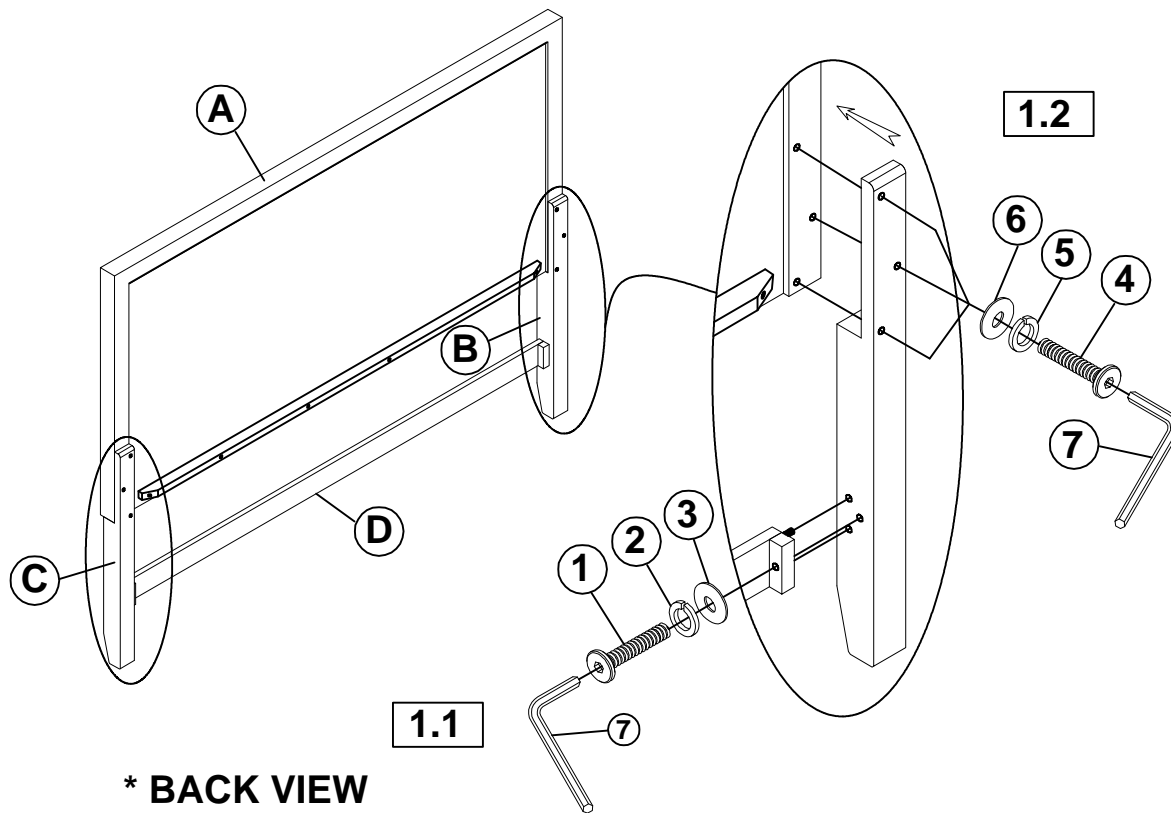

STEP 2

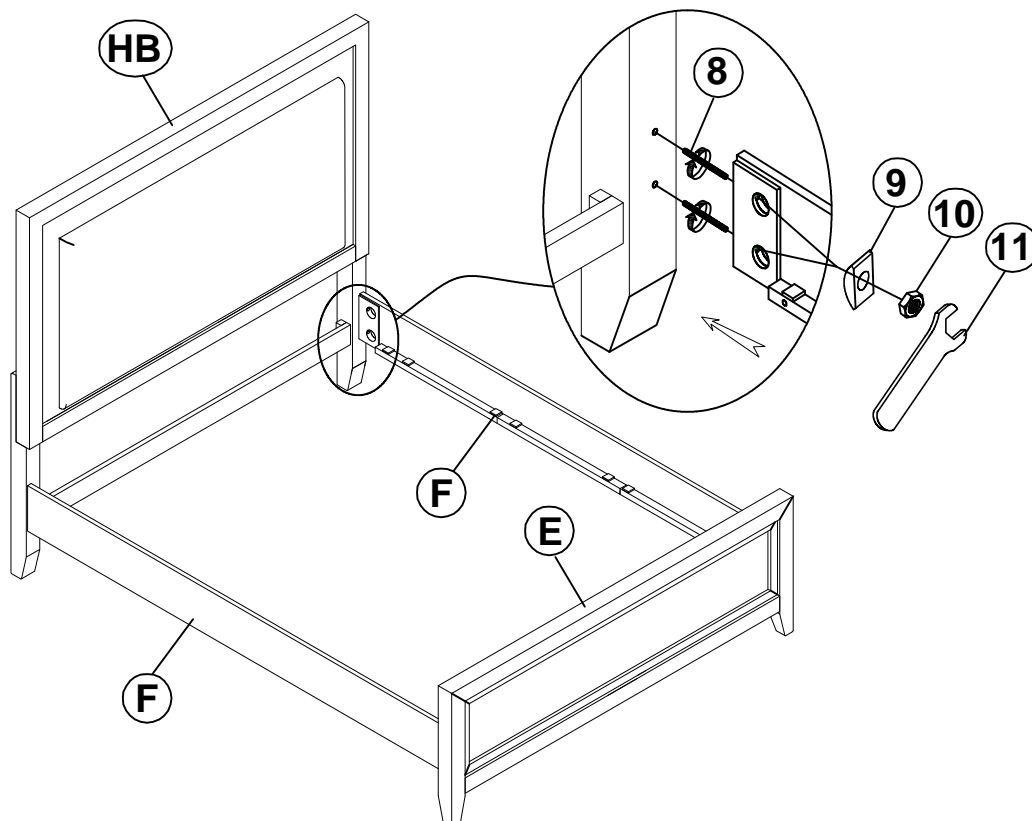

ITEM: 224841Q (B1-B3)



ASSEMBLY INSTRUCTIONS

STEP 3

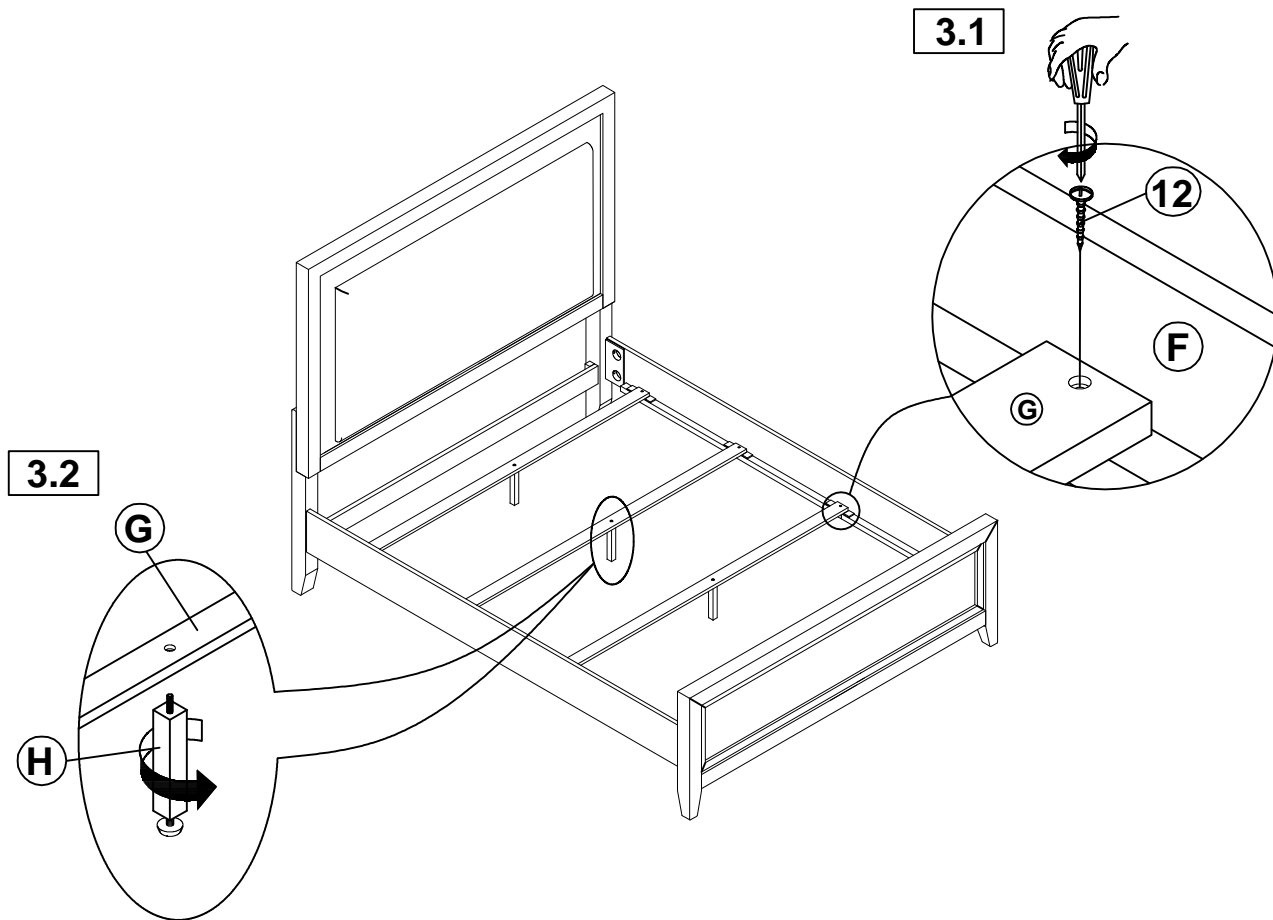

STEP 4 COMPLETE

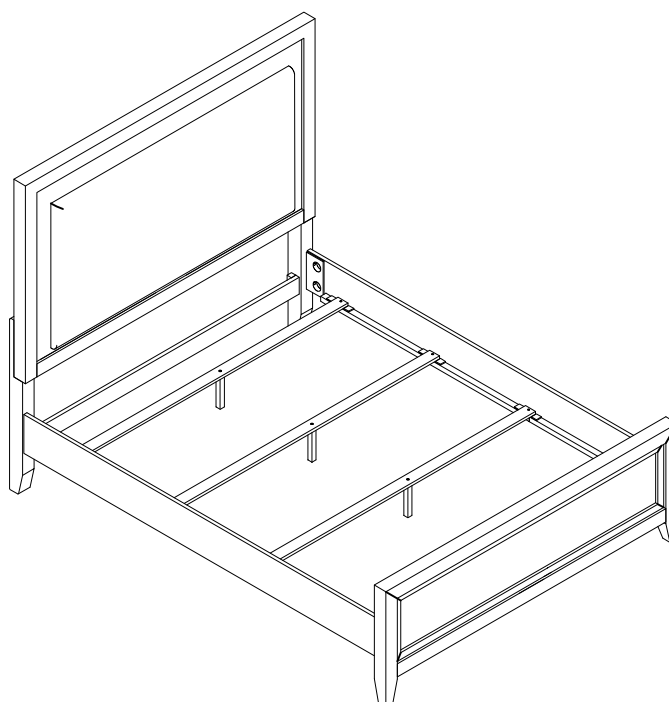

ITEM: **224841Q(B1-B3)**



Inner Size : 59.75"W X 82.00"D

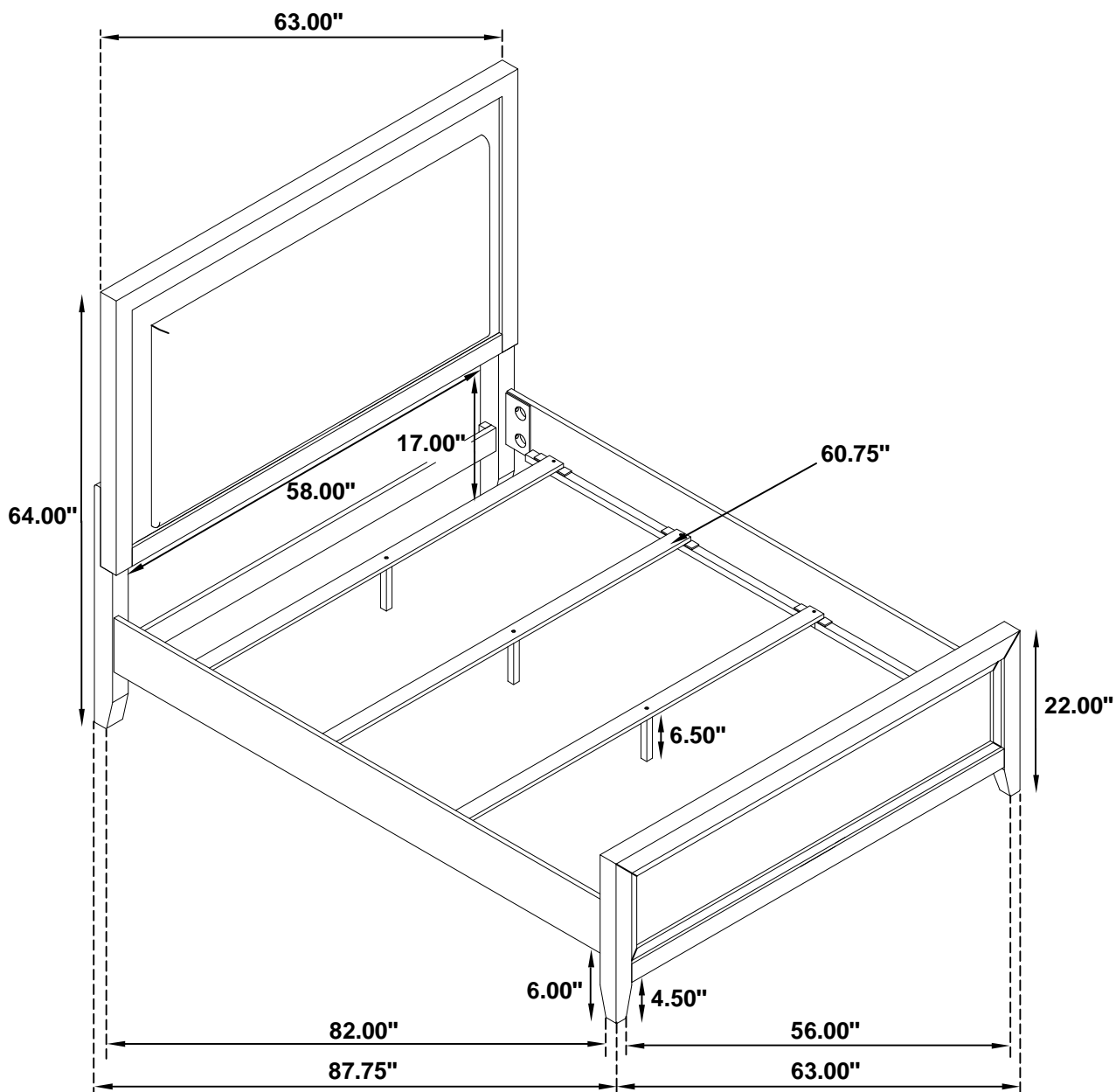

Note: Dimension tolerance $\pm 5\%$