

ASSEMBLY INSTRUCTIONS
COASTER FINE FURNITURE



Fine Furniture for every stage of life

182509
Bar Stool

ITEM:182509



ASSEMBLY INSTRUCTIONS

ASSEMBLY TIPS:

1. Remove hardware from box and sort by size.
2. Please check to see that all hardware and parts are present prior to start of assembly.
3. Please follow attached instructions in the same sequence as numbered to assure fast & easy assembly.



WARNING!







1. Don't attempt to repair or modify parts that are broken or defective. Please contact the store immediately.
2. This product is for home use only and not intended for commercial establishments.





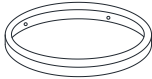

ASSEMBLY TIME

15 MINUTES

PARTS IDENTIFICATION

A	BACKREST		1PC
B	SWIVEL PLATE WITH FRAME		1PC
C	UPPER LEG		1PC
D	LOWER LEG		1PC
E	FOOTREST		1PC
F	SEAT CUSHION		1PC

HARDWARE IDENTIFICATION

1	BOLT (M6 x45MM - BLK)		14PCS
2	LOCK WASHER (1/4" - BLK)		14PCS
3	FLAT WASHER (1/4"x 16MM - BLK)		10PCS
4	FLAT HEAD SCREW (M4 x 32MM - BLK)		4PC
5	ALLEN WRENCH (M4 x 65MM - BLK)		1PC

NOTE:

Quantities shown are for one stool.

Phillips head screw driver is required in the assembly process; however, manufacturer does not provide this item.

ITEM: **182509**



ASSEMBLY INSTRUCTIONS

STEP 1

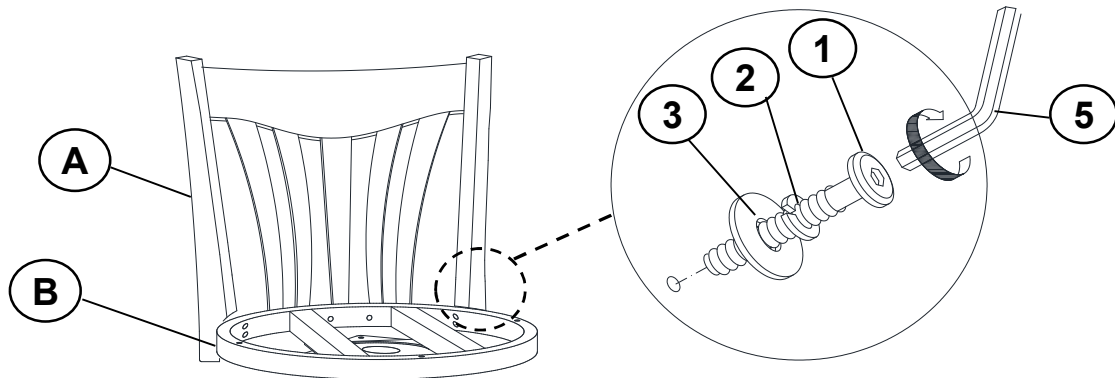

STEP 2

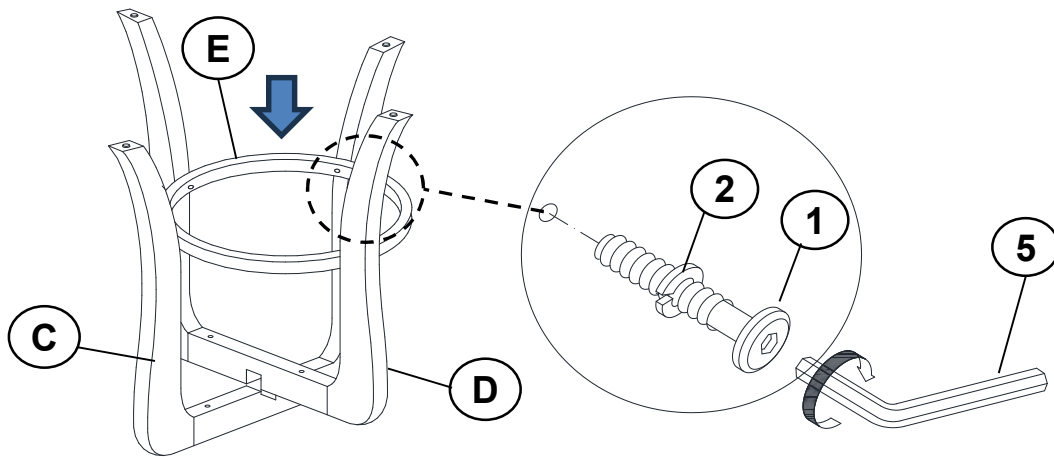

STEP 3

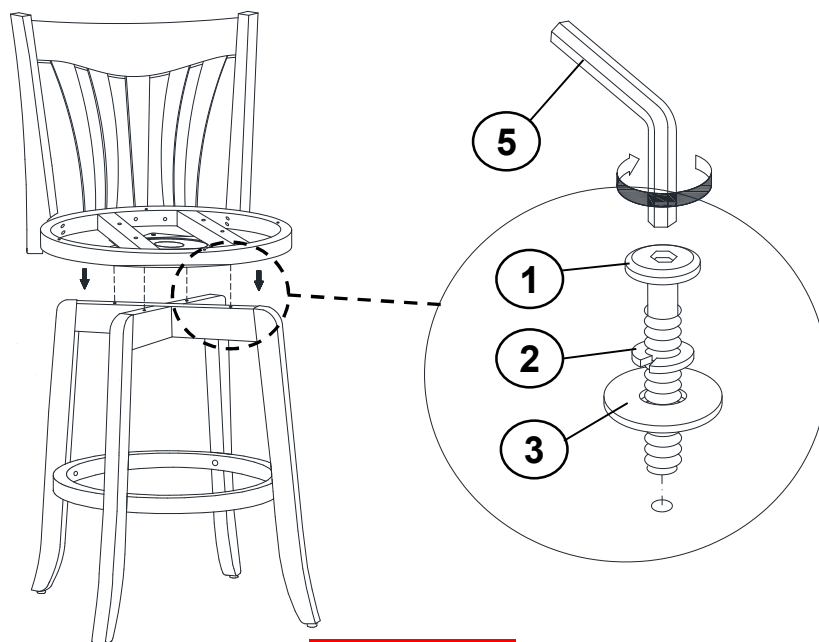

ITEM: **182509**

ASSEMBLY INSTRUCTIONS



STEP 4

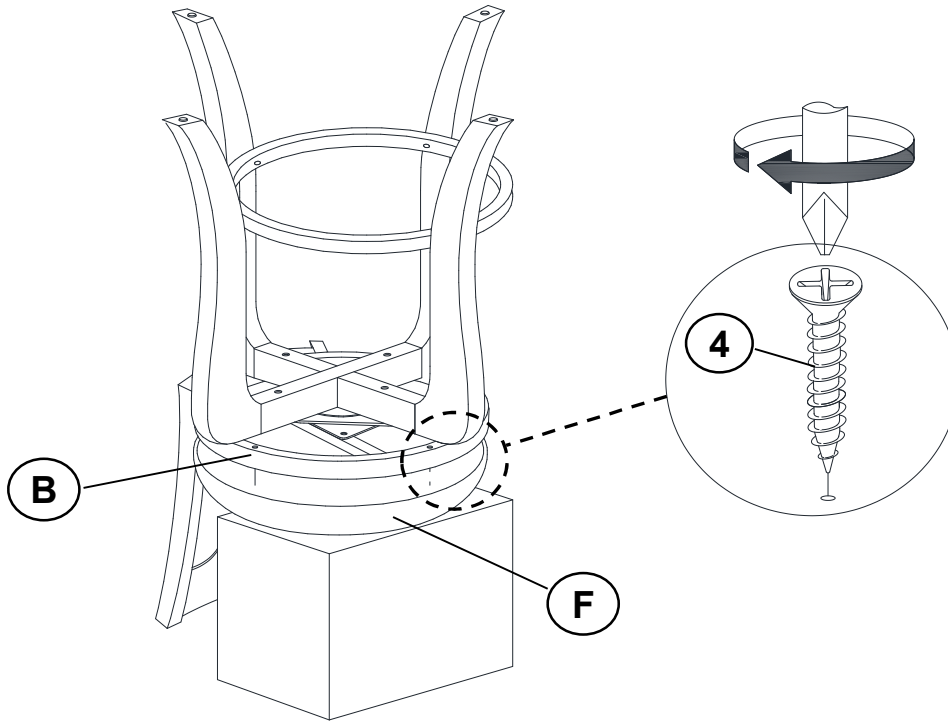

STEP 5
COMPLETE

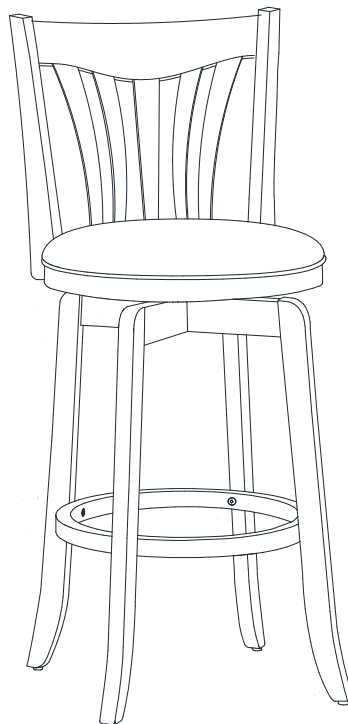

ITEM:182509

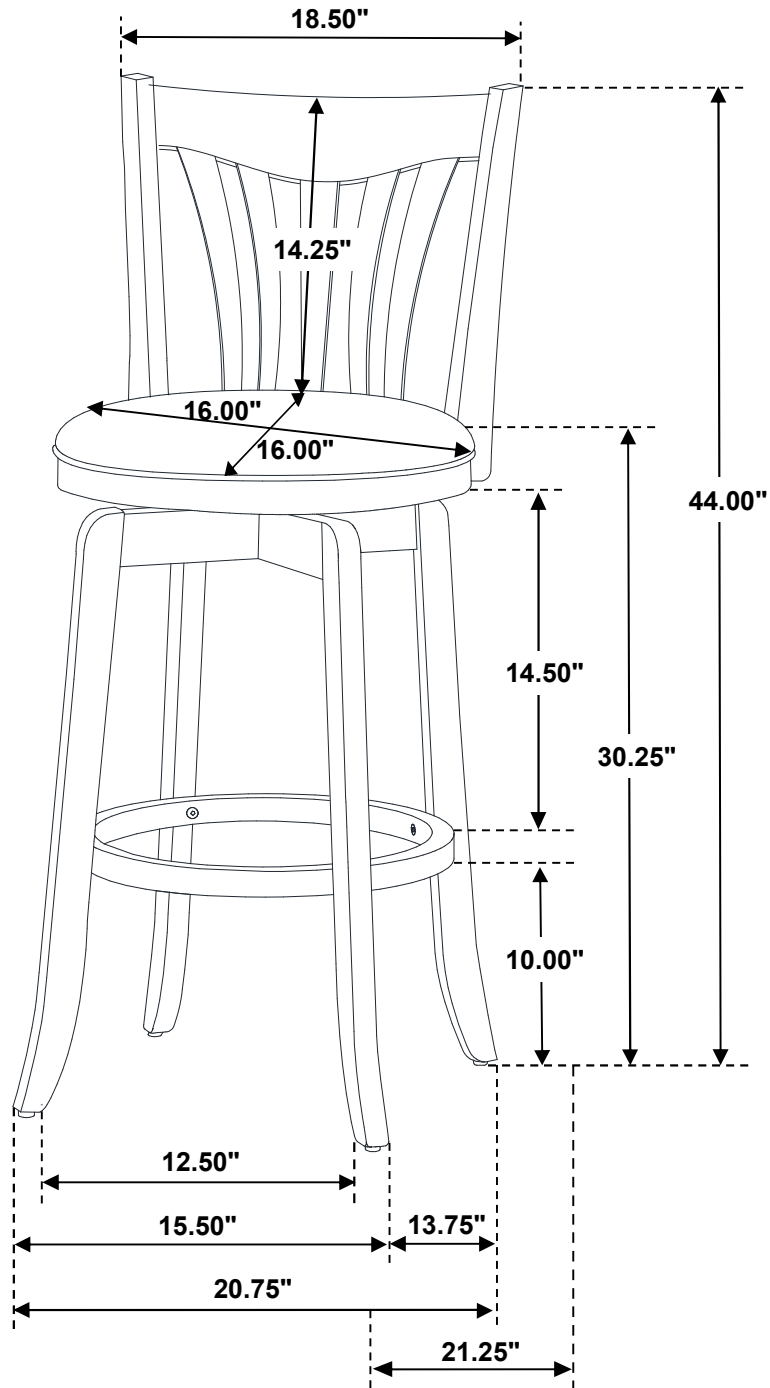

Note: Dimension tolerance $\pm 5\%$