



ASSEMBLY INSTRUCTIONS COASTER FINE FURNITURE



903094
ACCENT CHAIR

ITEM:903094



ASSEMBLY INSTRUCTIONS

ASSEMBLY TIPS:

1. Remove hardware from box and sort by size.
2. Please check to see that all hardware and parts are present prior to start of assembly.
3. Please follow attached instructions in the same sequence as numbered to assure fast & easy assembly.



WARNING!

1. Don't attempt to repair or modify parts that are broken or defective. Please contact the store immediately.
2. This product is for home use only and not intended for commercial establishments.







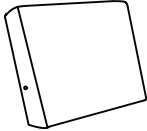
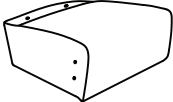
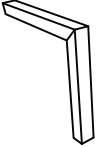
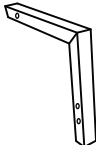



ASSEMBLY TIME 5 MINUTES

PARTS IDENTIFICATION:

A	BACK		1PC
B	SEAT		1PC
C	LEFT ARM		1PC
D	RIGHT ARM		1PC

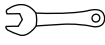
Z HARDWARE IDENTIFICATION

NO	DESCRIPTION	FIGURE	QTY
1	BOLT (M8 x 45mm)-SR		4 PCS
2	BOLT (M8 x 60mm)-SR		2 PCS
3	FLAT WASHER (M8)-SR		6 PCS
4	IRON SHEET		2 PCS
5	NUT		2 PCS
6	BOLT		2 PCS
7	OPEN END WRENCH		1 PC
8	ALLEN KEY (M6)-SR		1 PC

ITEM: 903094

ASSEMBLY INSTRUCTIONS



STEP 1

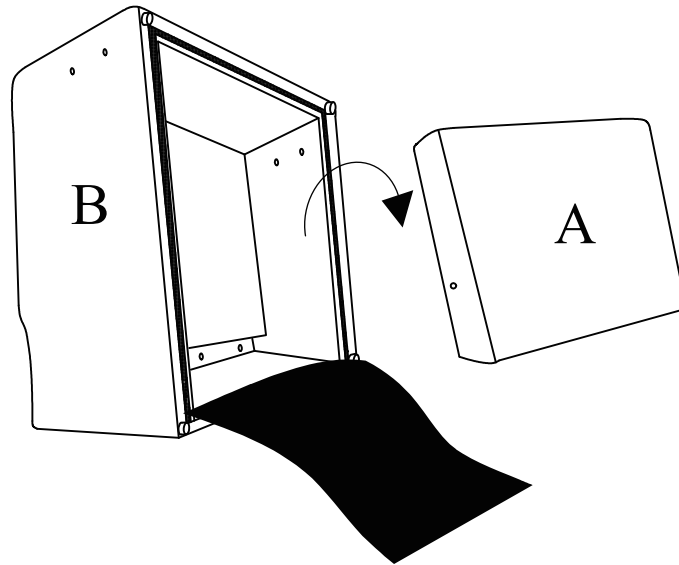

STEP 2

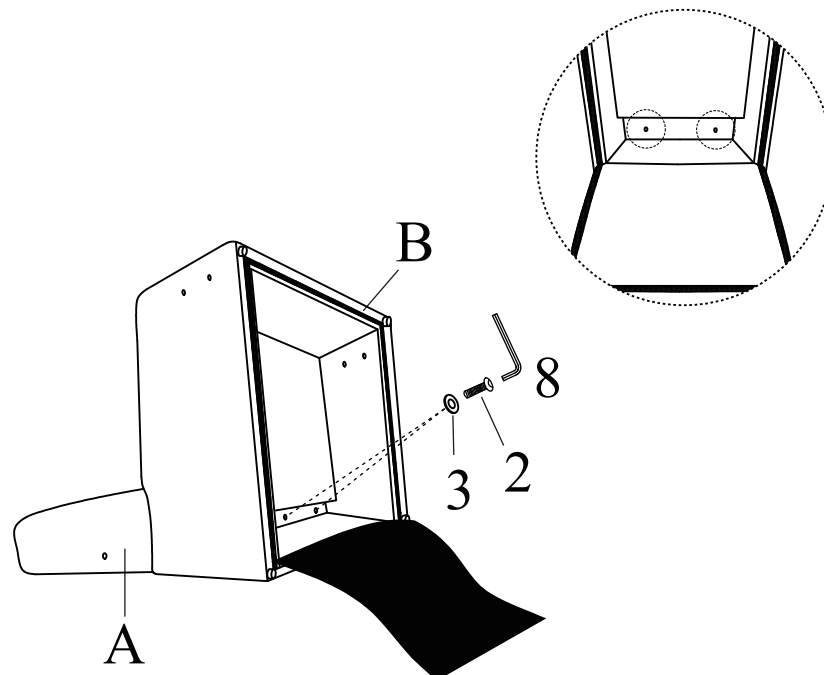

COASTERFURNITURE.COM

ITEM:903094

ASSEMBLY INSTRUCTIONS



STEP 3

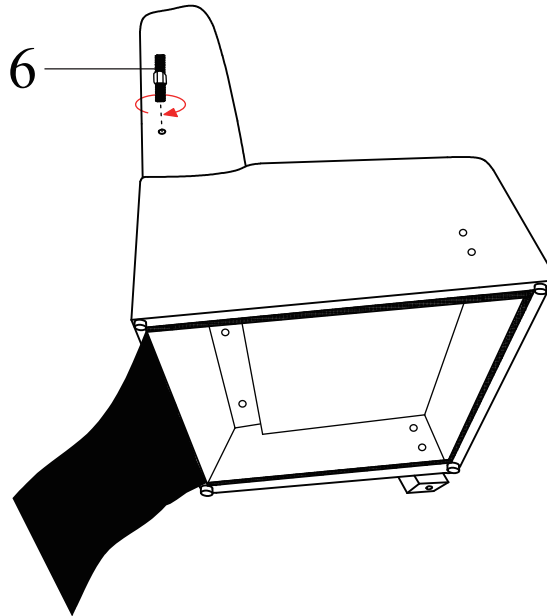

STEP 4

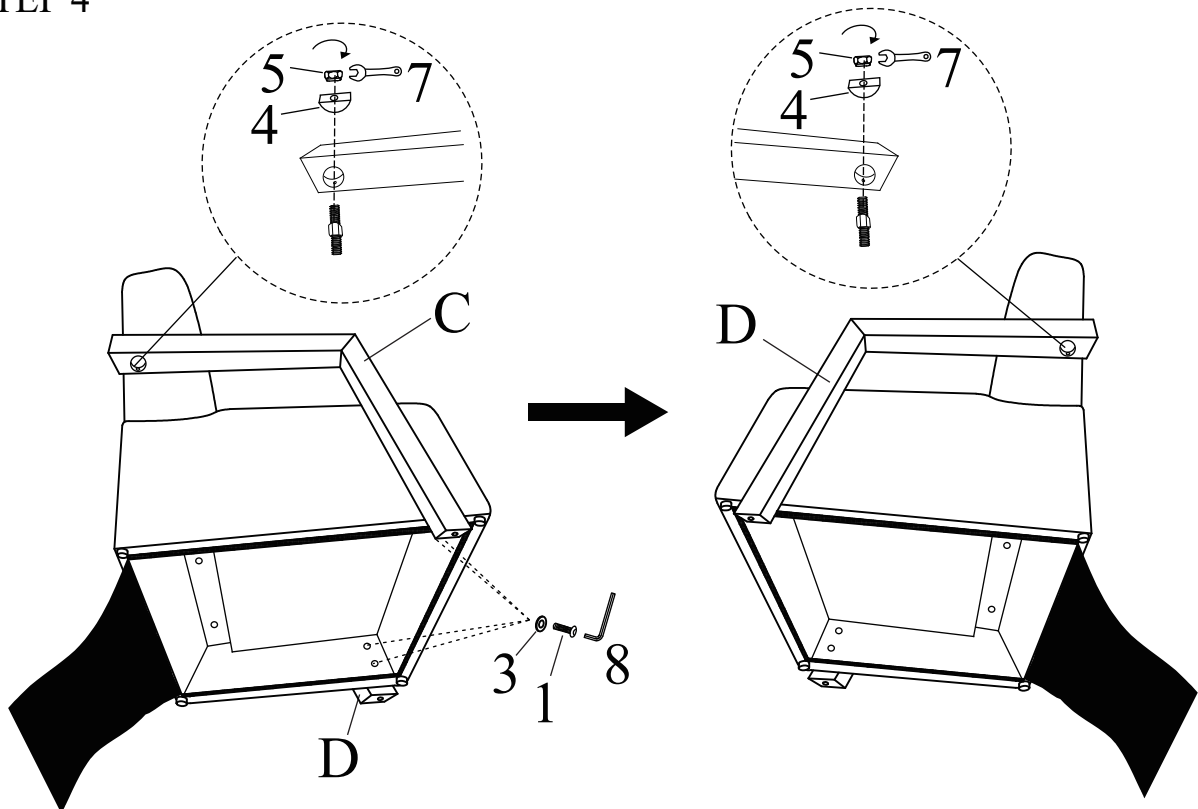

COASTERFURNITURE.COM

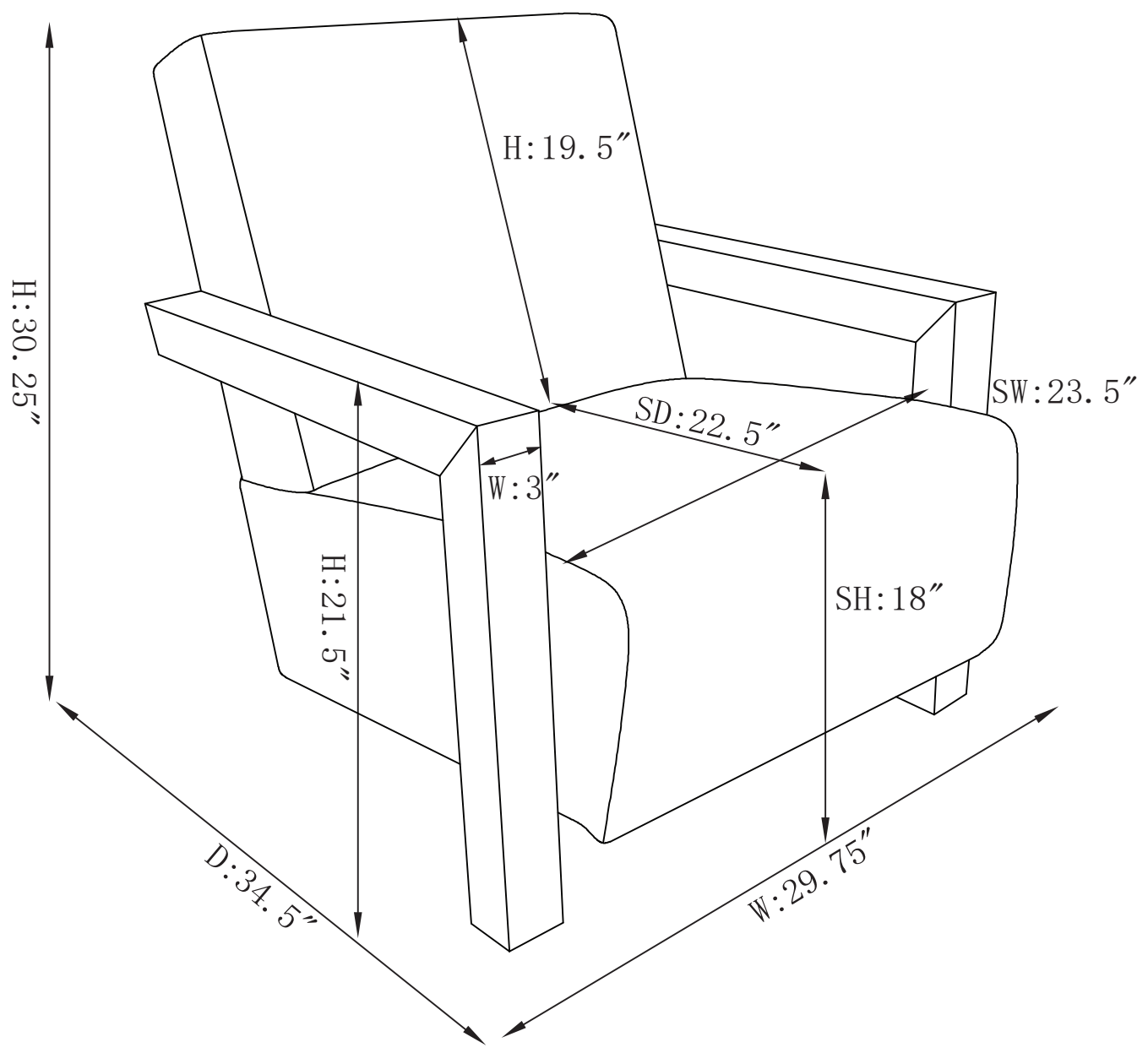

Note : Dimension tolerance $\pm 5\%$

