

**ASSEMBLY INSTRUCTIONS**  
**COASTER FINE FURNITURE**



*Fine Furniture for every stage of life*

**100439**  
**BAR CABINET**

# ITEM: 100439



## ASSEMBLY INSTRUCTIONS

### ASSEMBLY TIPS:

1. Remove hardware from box and sort by size.
2. Please check to see that all hardware and parts are present prior to start of assembly.
3. Please follow attached instructions in the same sequence as numbered to assure fast & easy assembly.



### WARNING!

1. Don't attempt to repair or modify parts that are broken or defective. Please contact the store immediately.
2. This product is for home use only and not intended for commercial establishments.



ASSEMBLY TIME

70 MINUTES

## PARTS IDENTIFICATION

A	LEFT DIVIDER PANEL		1 PC	G	CROSS BRACE		1 PC
B	RIGHT DIVIDER PANEL		1 PC	H	SMALL CROSS PANEL		15PCS
C	SIDE SUPPORT		2 PCS	I	UPPER CROSS PANEL		1 PC
D	LOWER LEFT DIVIDER PANEL		2 PCS	J	ADJUSTABLE SHELF		1 PC
E	LOWER MIDDLE DIVIDER PANEL		1 PC	K	TOP PANEL		1 PC
F	BOTTOM PANEL		1 PC	L	LARGE CROSS PANEL		6 PCS

### NOTE:

Phillips head screw driver is required in the assembly process; however, manufacturer does not provide this item.



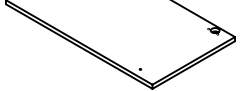



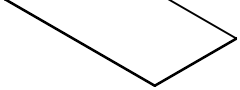



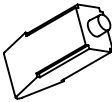
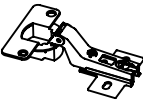
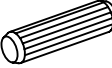

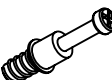
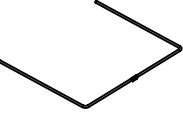

# ITEM: 100439

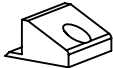
M DOOR  1 PC

O GLASS  1 PC

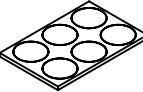
N BACK PANEL  2 PCS

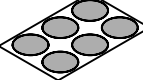
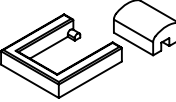
## HARDWARE IDENTIFICATION

Z	NO	DESCRIPTION	FIGURE	Q'TY	NO	DESCRIPTION	FIGURE	Q'TY
	1	GLUE 40g		2 PCS	11	HINGE		2 PCS
	2	WOODEN DOWEL Ø 8x30mm		68 PCS	12	HINGE SCREW Ø 4x15mm		8 PCS
	3	WOODEN DOWEL Ø 8x50mm		20 PCS	13	HANGING CUP HOLDER		1 PC
	4	CAM BOLT Ø 7x35.5mm		34 PCS	14	□ - sharpened iron bar		6 PCS
	5	CAM LOCK Ø 15x12mm		34 PCS	15	FIXER		6 PCS
	6	SCREW Ø 4.5x42mm		2 PCS	16	FIXER SCREW Ø 3x19mm		16 PCS
	7	PIN Ø 4.9x8mm		4 PCS	17	FILLING PIECE Ø 12mm x 6 HOLE		1 PC
	8	PLASTIC FEET Ø 15mm		7 PCS	18	STICKER Ø 20mm		6 PCS
	9	HANDLE		1 PC	19	SCREW DRIVER		1 PC
	10	HANDLE BOLT		1 PC				

Z9,Z10,Z11,Z13,Z14 not included in blister packaging.

**NOTE:**

Phillips head screw driver is required in the assembly process; however, manufacturer does not provide this item.

ITEM: 100439

**COASTER**  
FINE FURNITURE

**STEP 1**

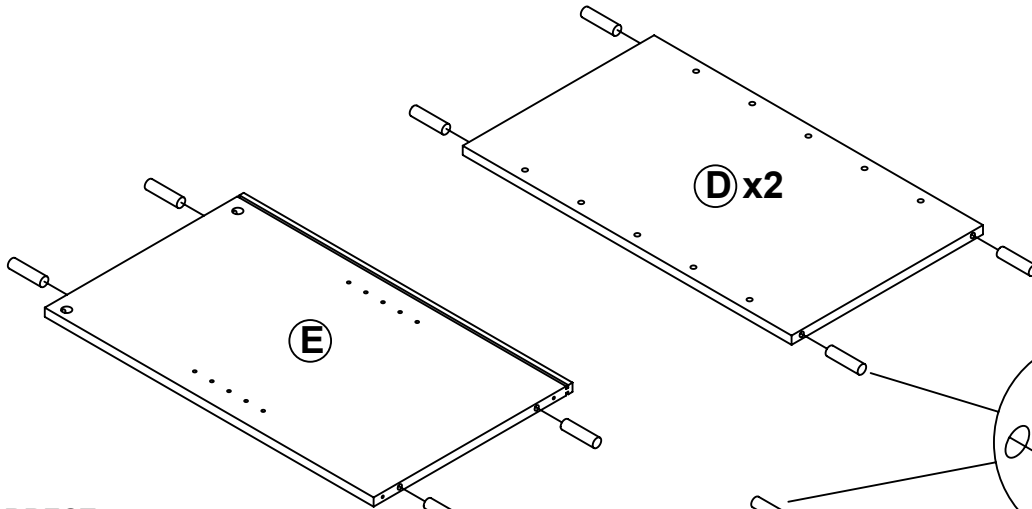
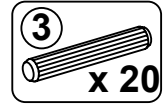
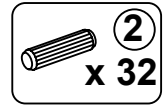

INCORRECT  
CORRECT

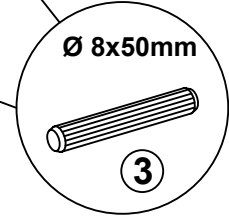
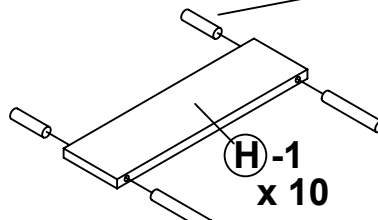
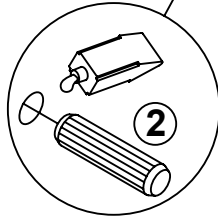
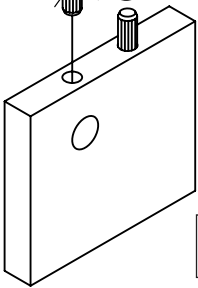

Apply glue on all wooden dowels to ensure integrity of the structure.

**STEP 2**

Apply glue on all wooden dowels to ensure integrity of the structure.

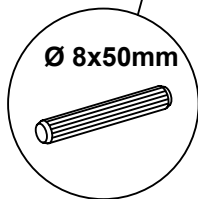
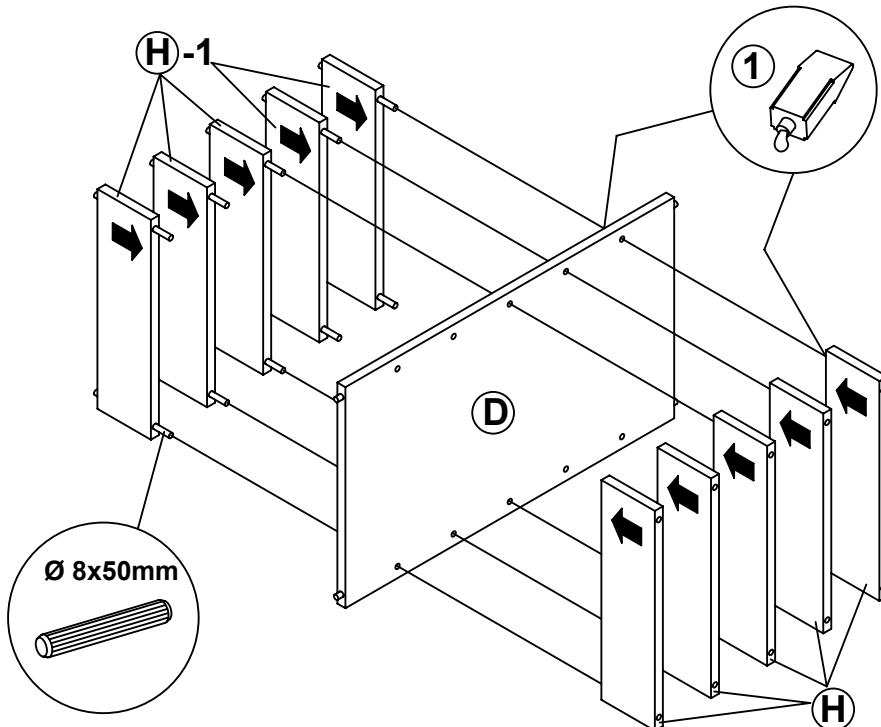

**STEP 3**

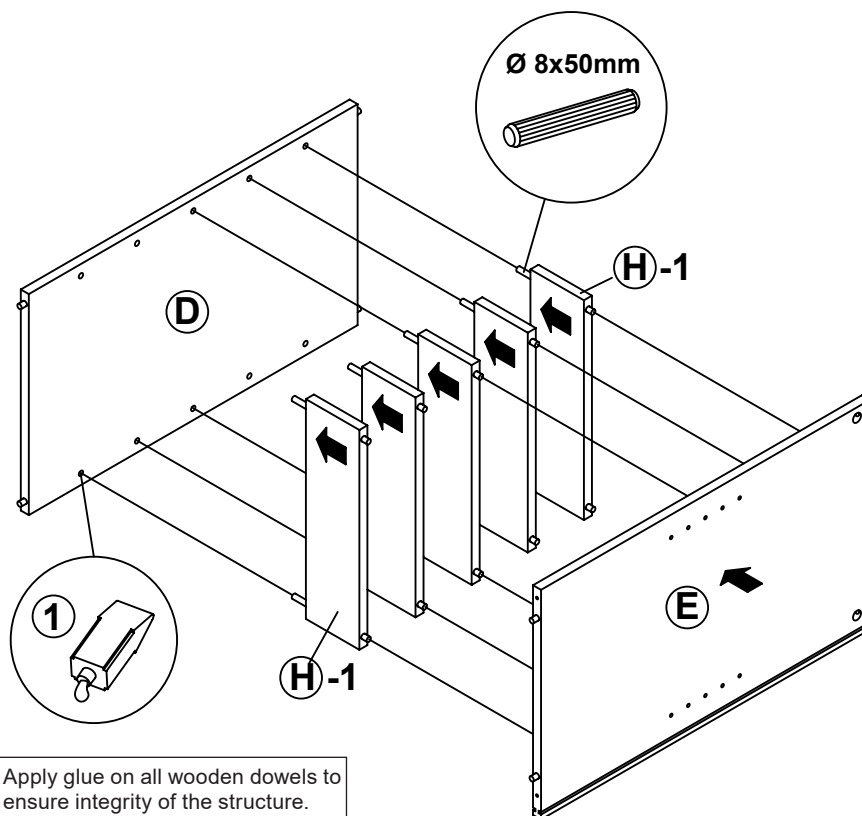

**STEP 4**

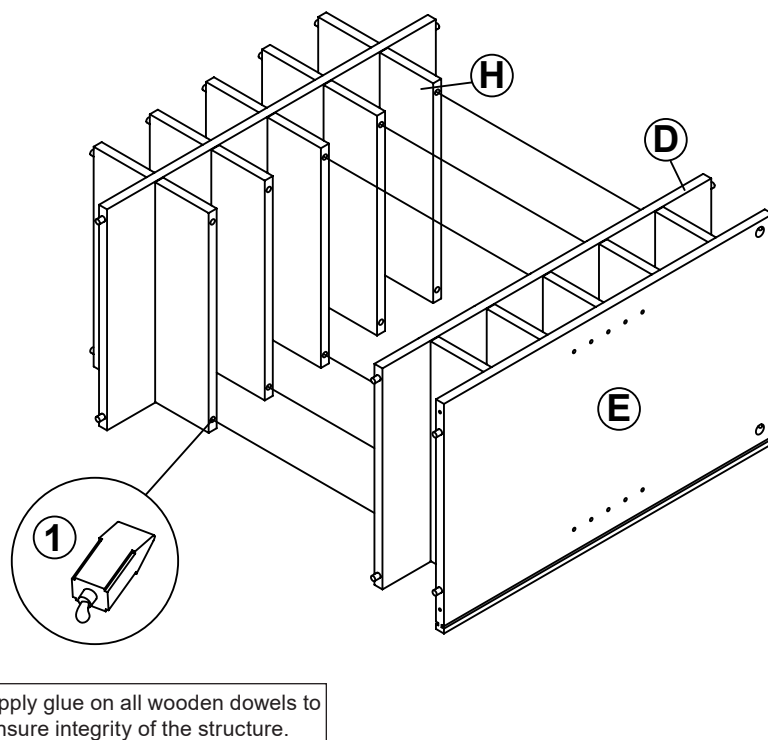

ITEM: 100439

**STEP 5**

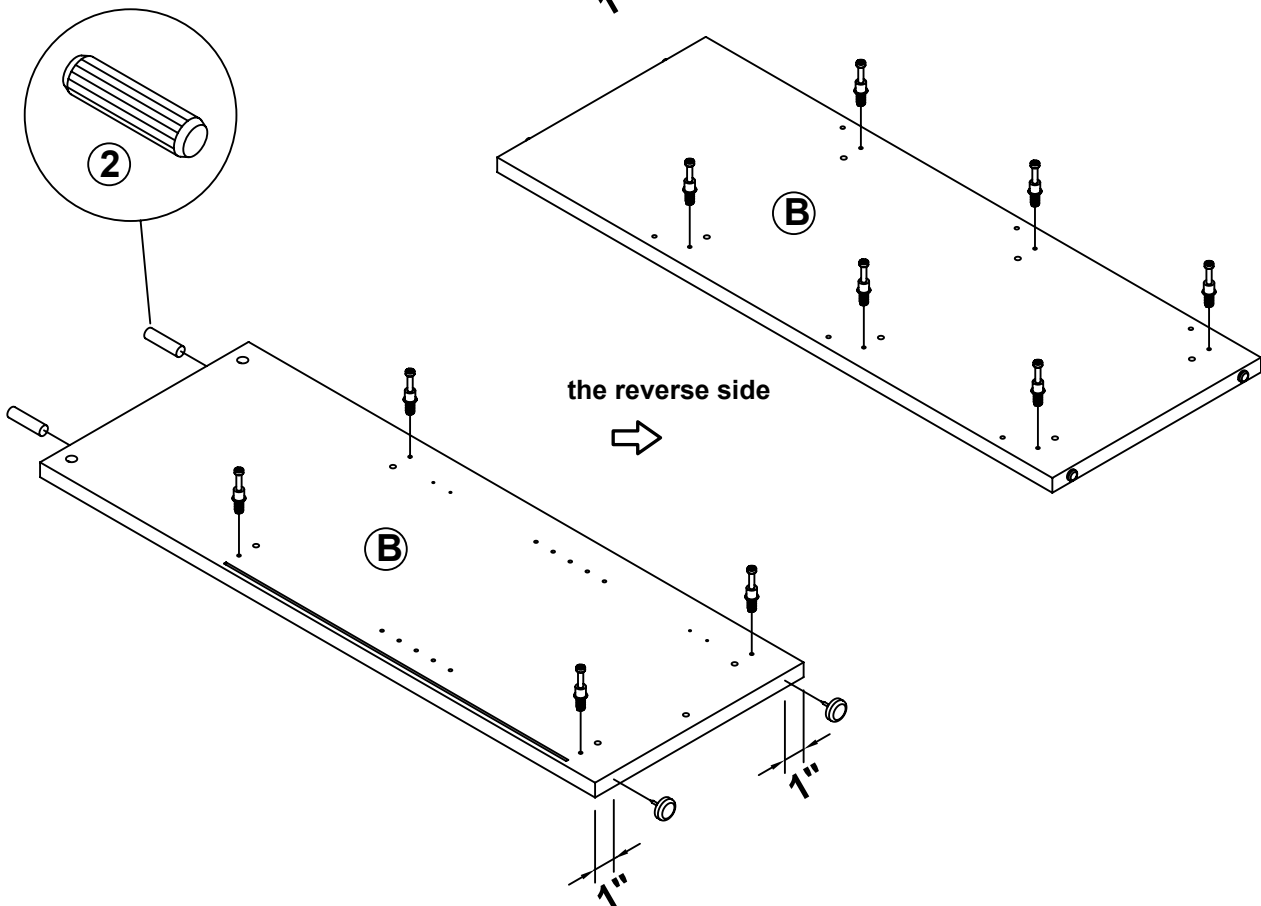
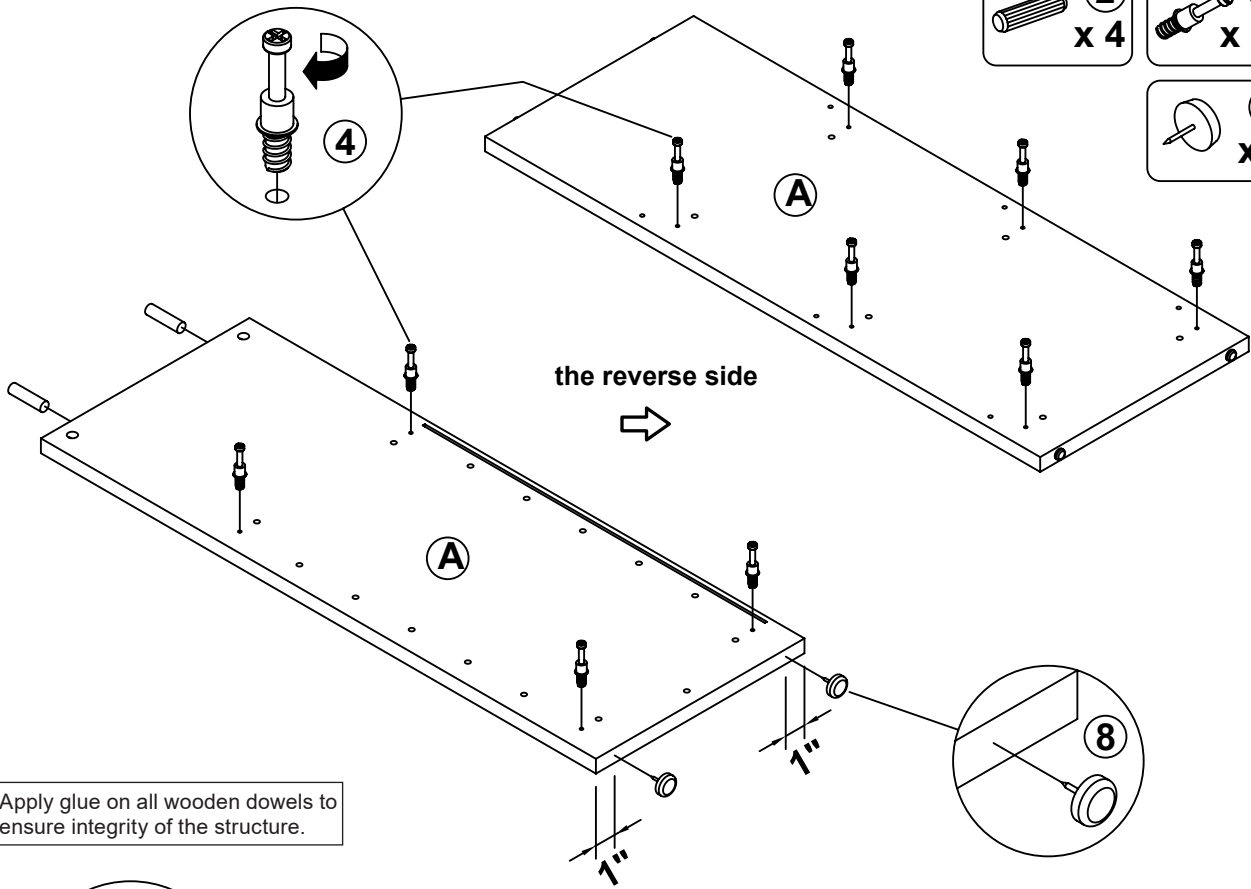
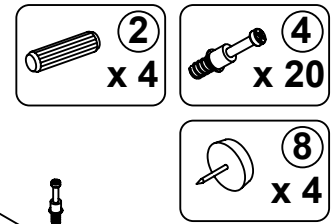

# ITEM: 100439

## STEP 6

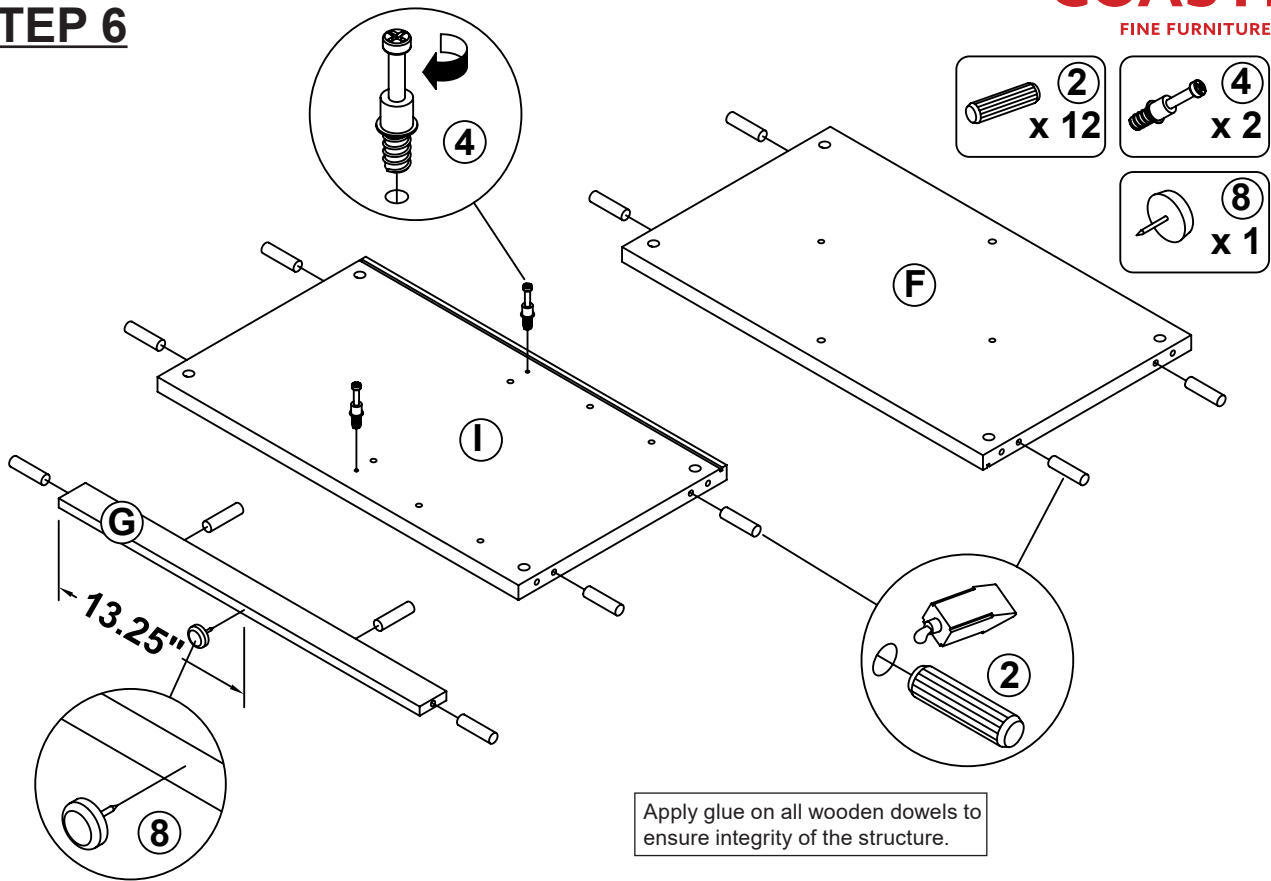

## STEP 7

Apply glue on all wooden dowels to ensure integrity of the structure.

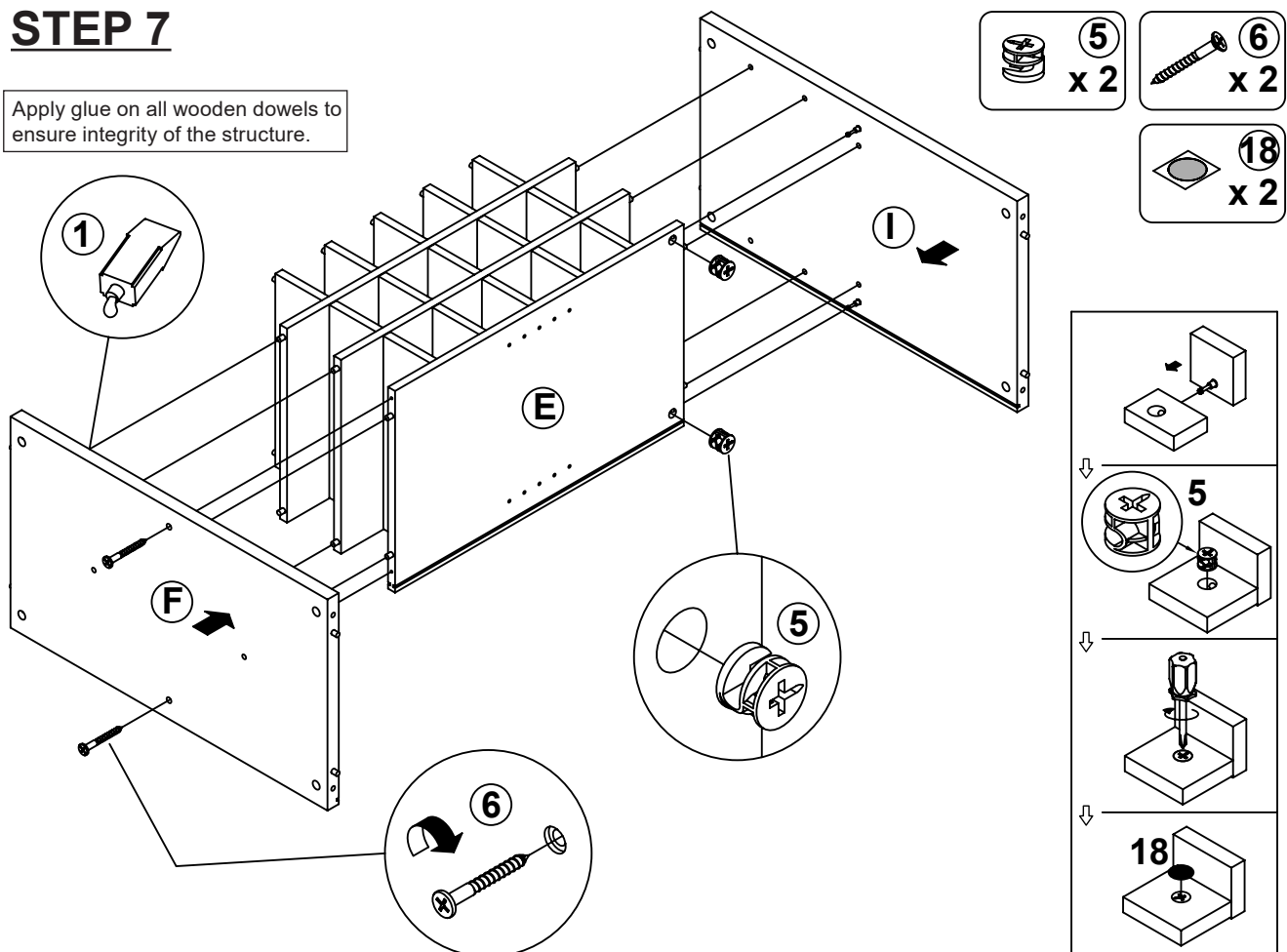

ITEM: 100439

**STEP 8**

Apply glue on all wooden dowels to ensure integrity of the structure.

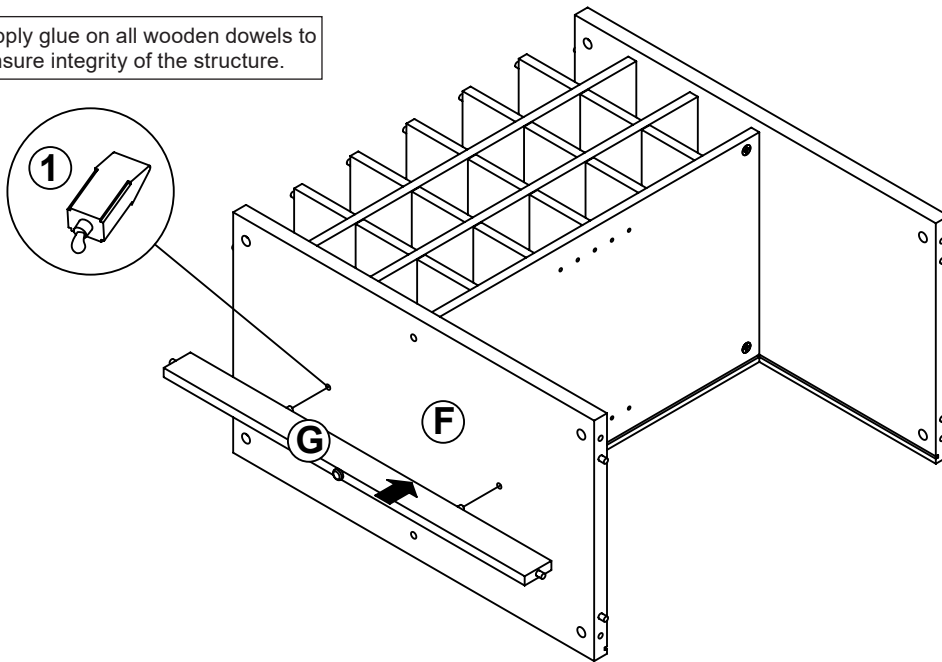

**STEP 9**

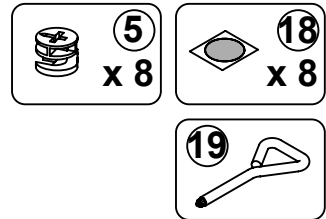

Apply glue on all wooden dowels to ensure integrity of the structure.

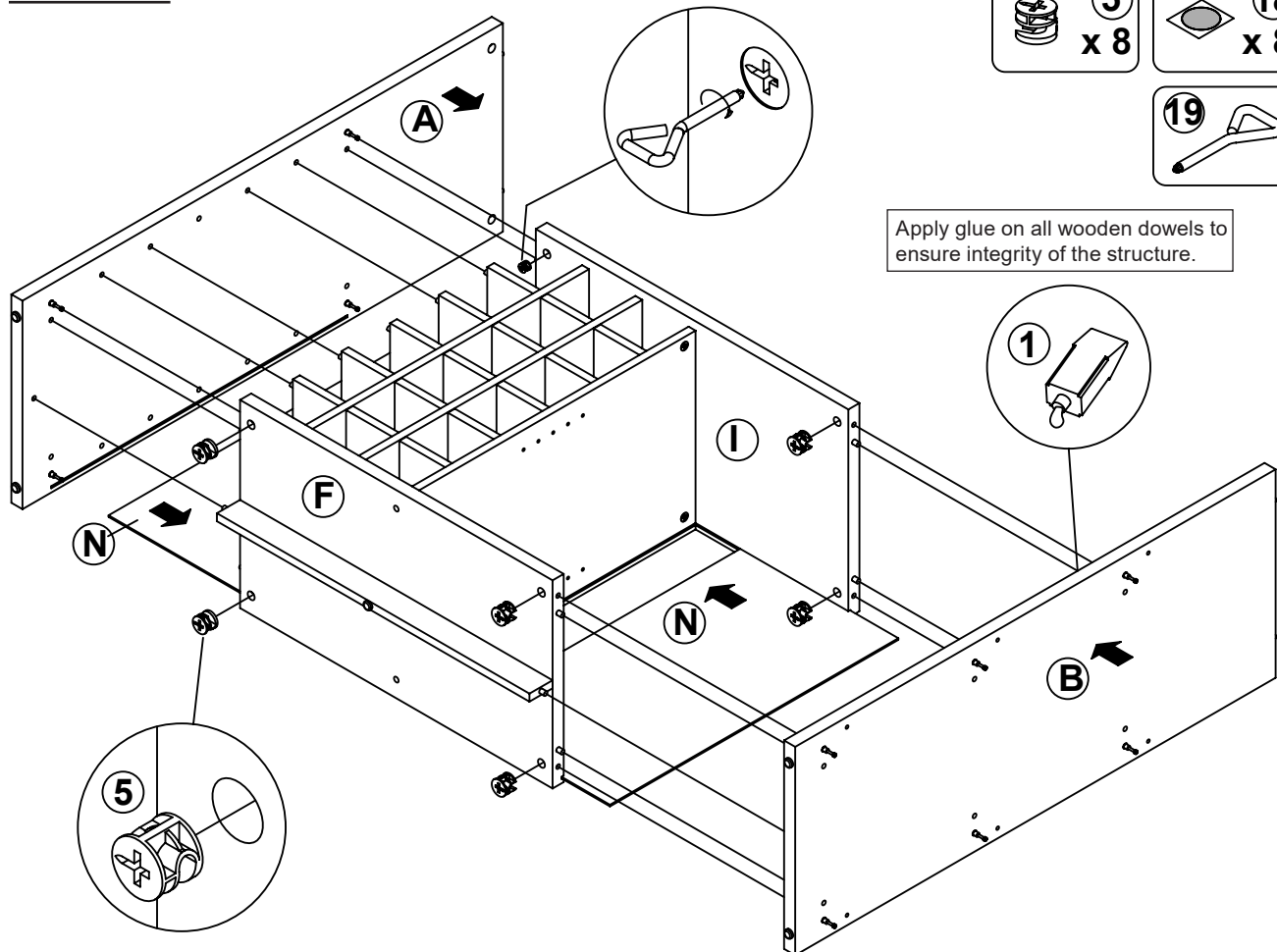



# ITEM: 100439

## STEP 10

Apply glue on all wooden dowels to ensure integrity of the structure.

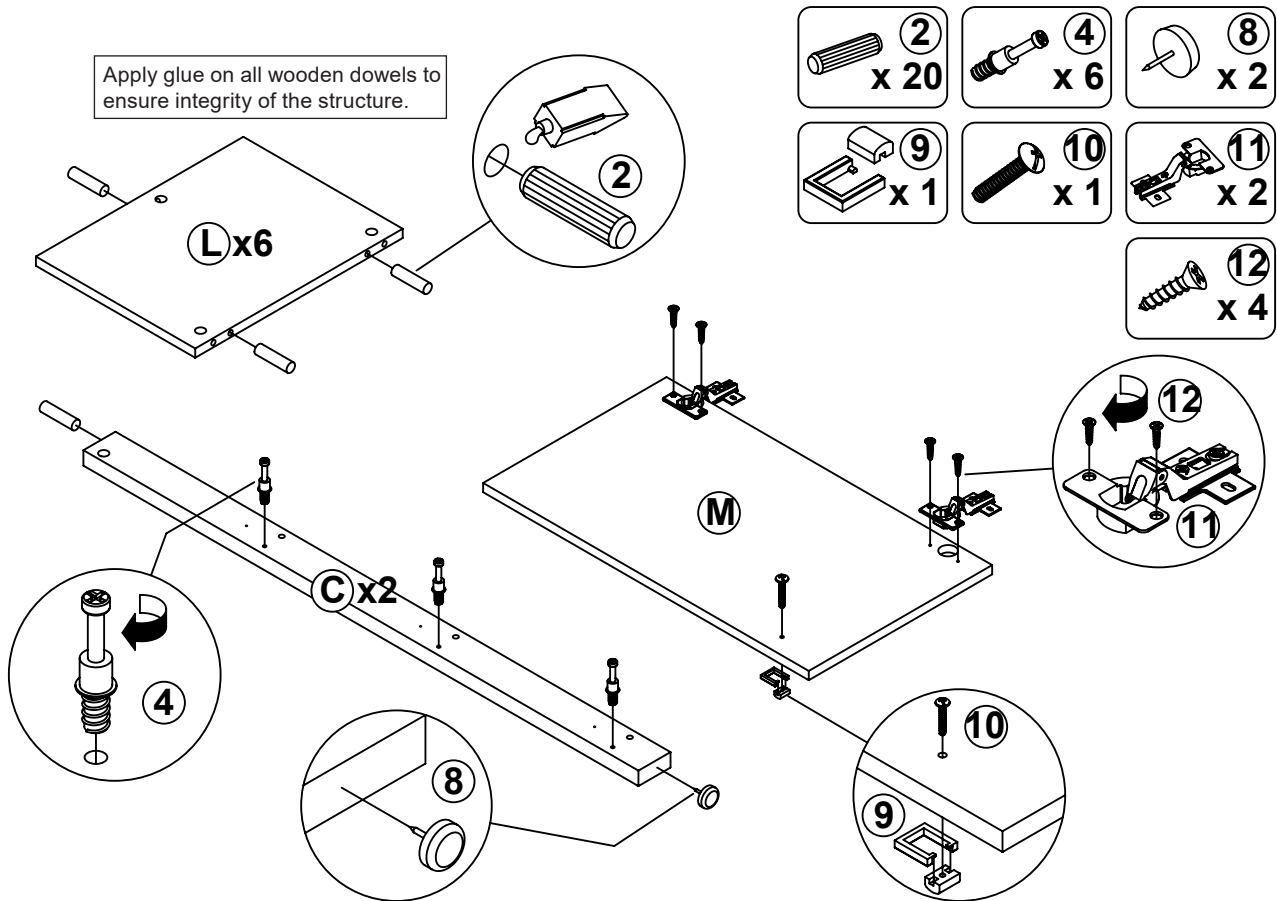

## STEP 11

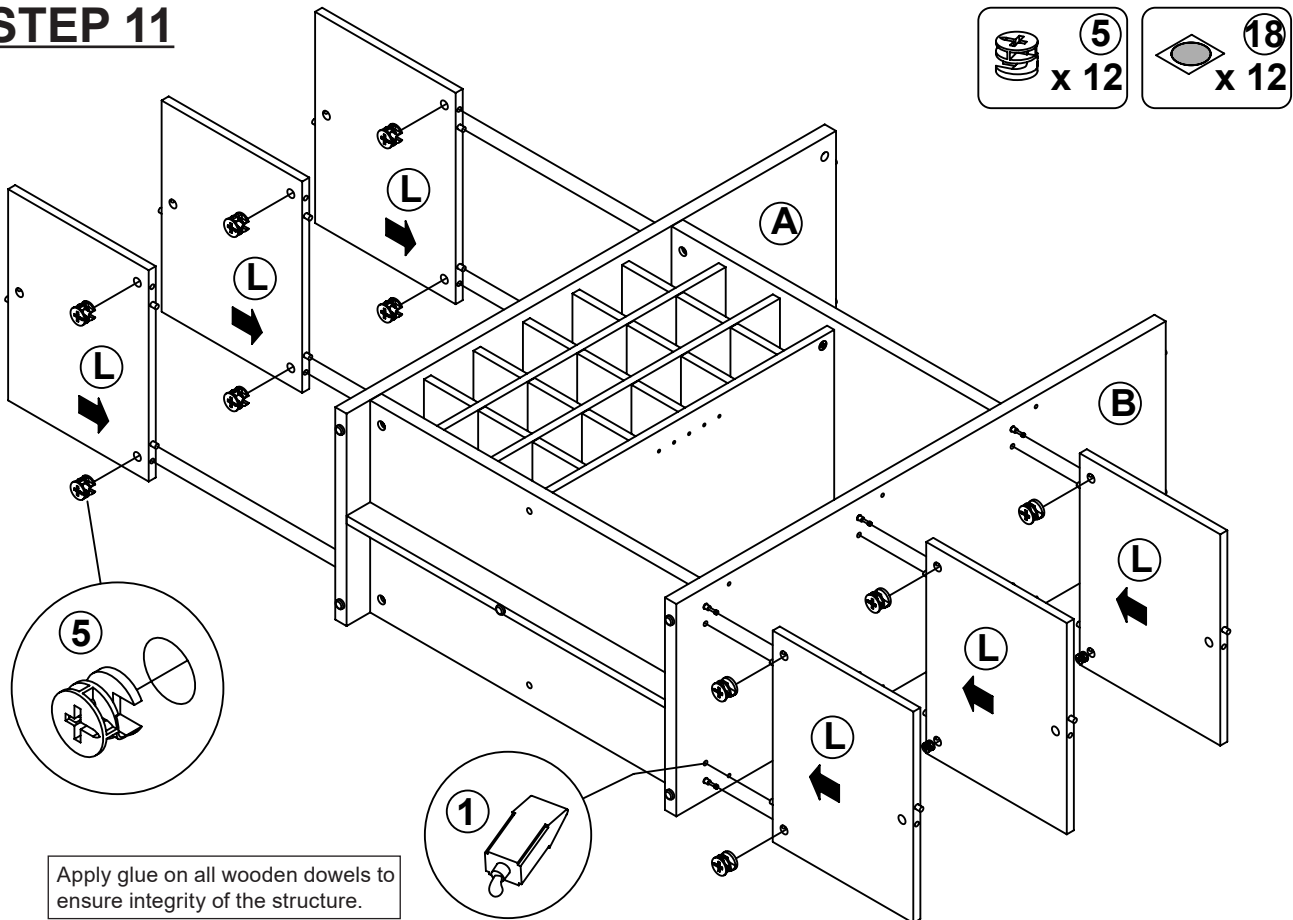

ITEM: 100439

**STEP 12**

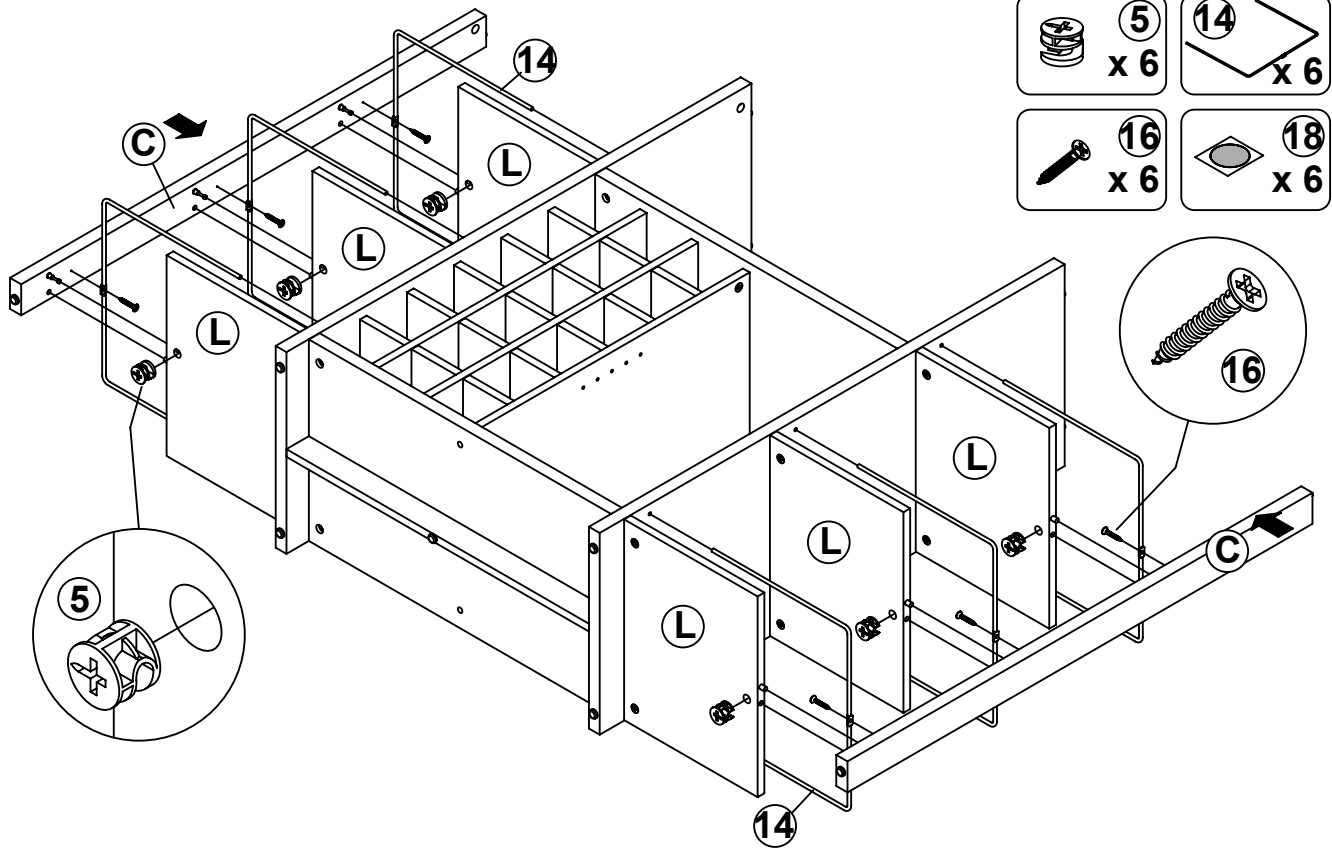

**STEP 13**

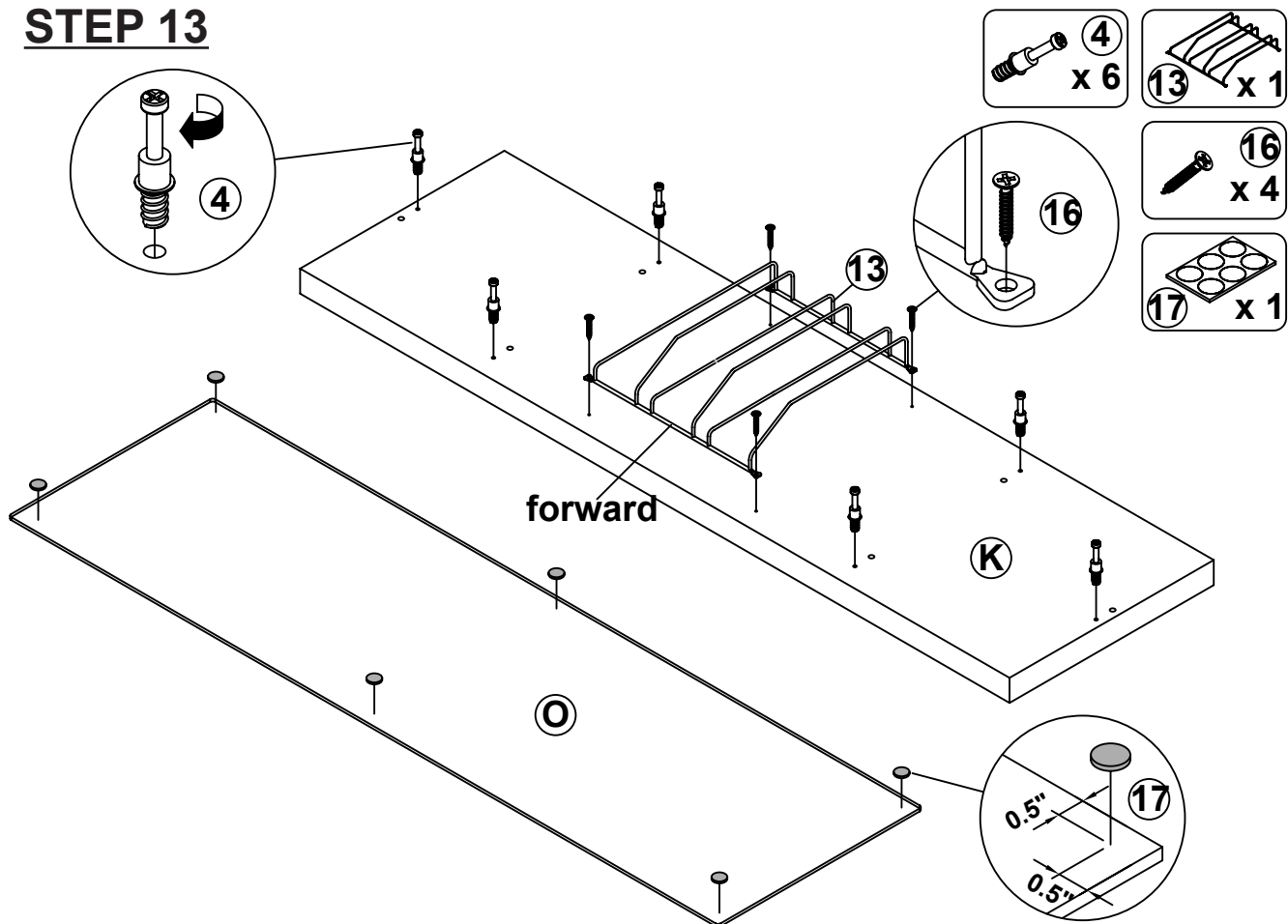

ITEM: 100439

**COASTER**  
FINE FURNITURE

**STEP 14**

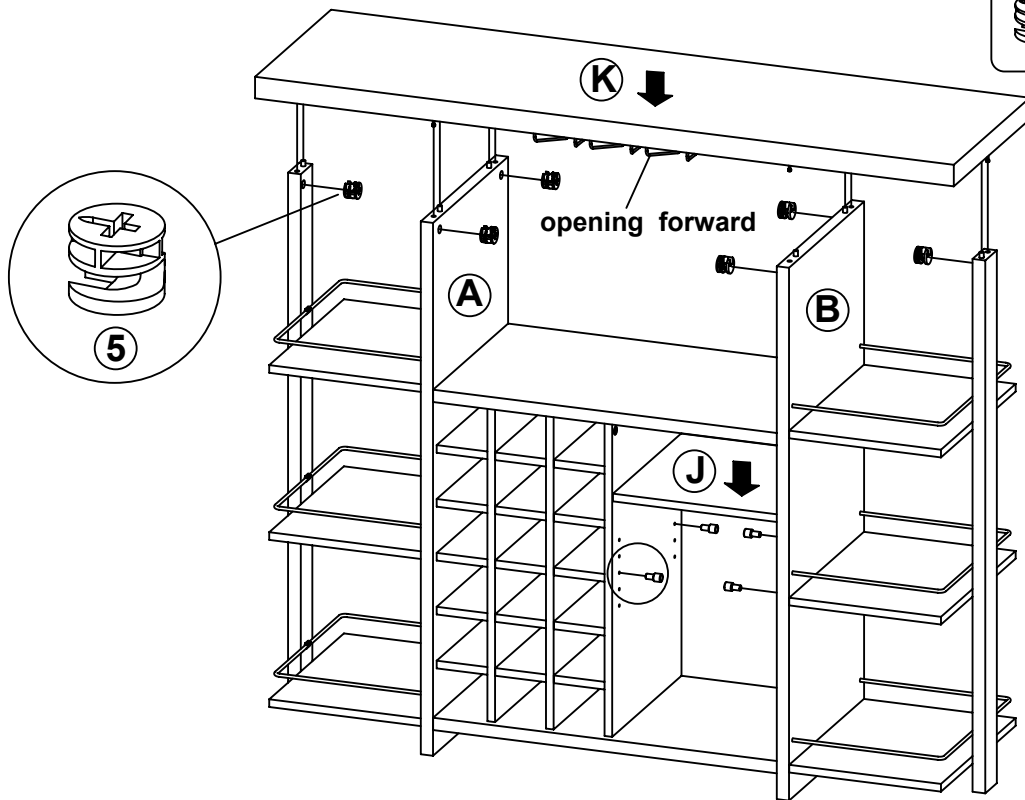

**STEP 15**

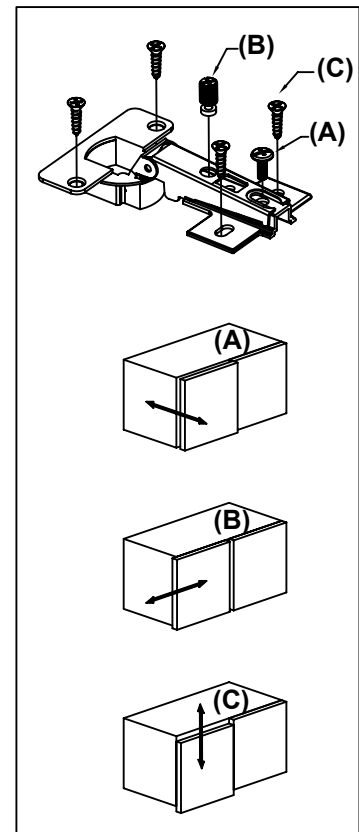
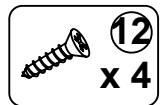
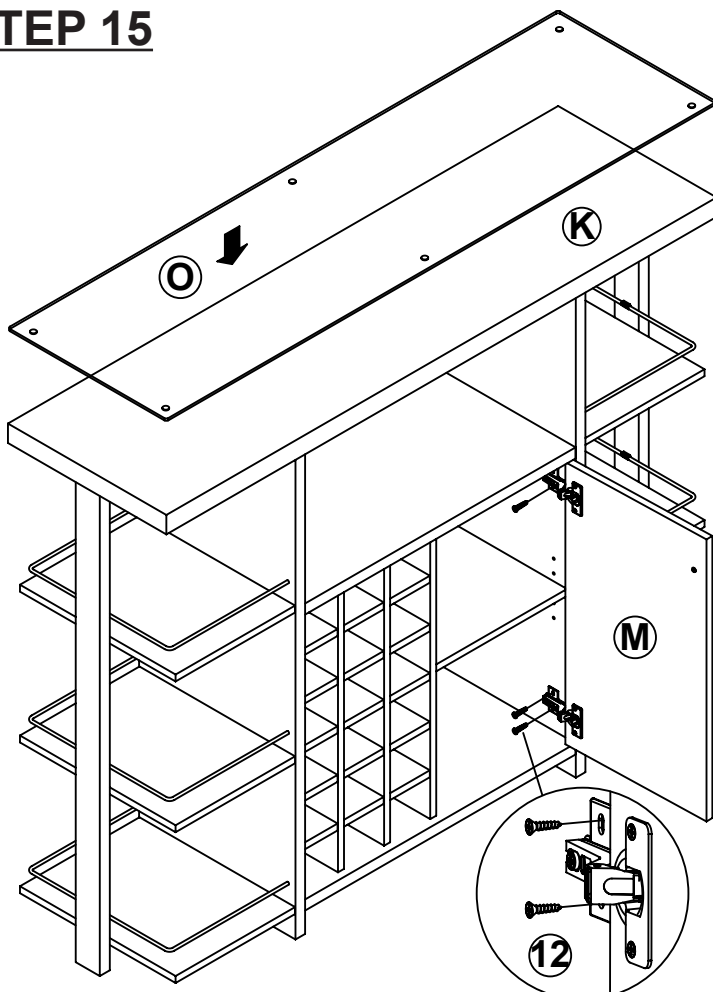

ITEM: 100439

**STEP 16**

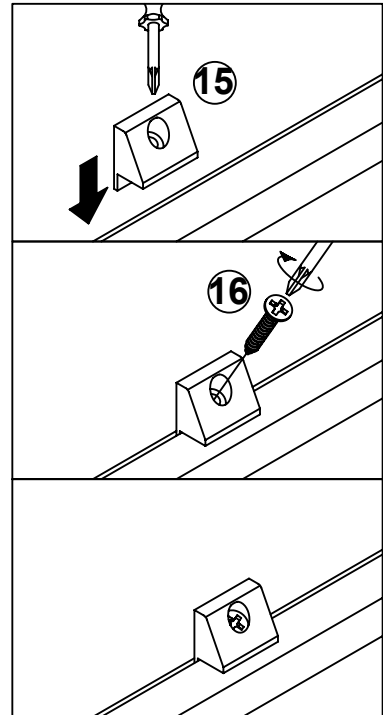
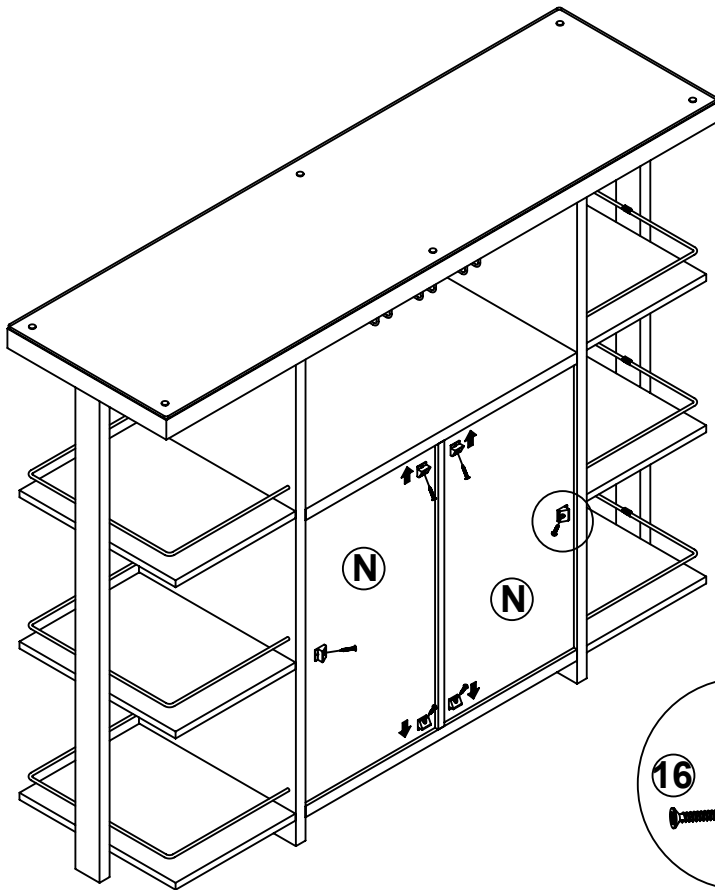
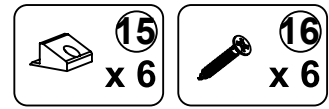

**STEP 17**  
**COMPLETE**

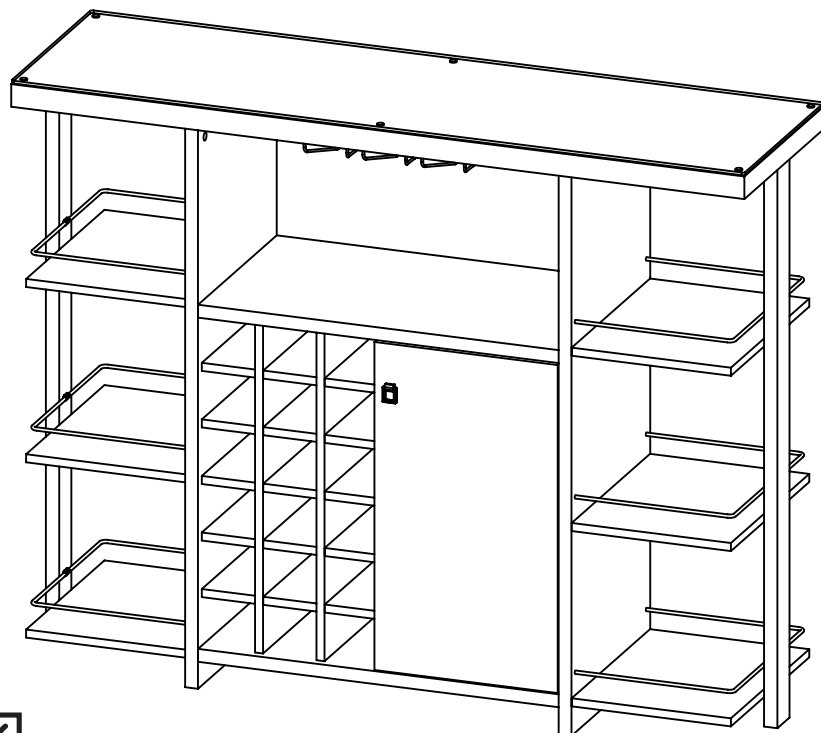

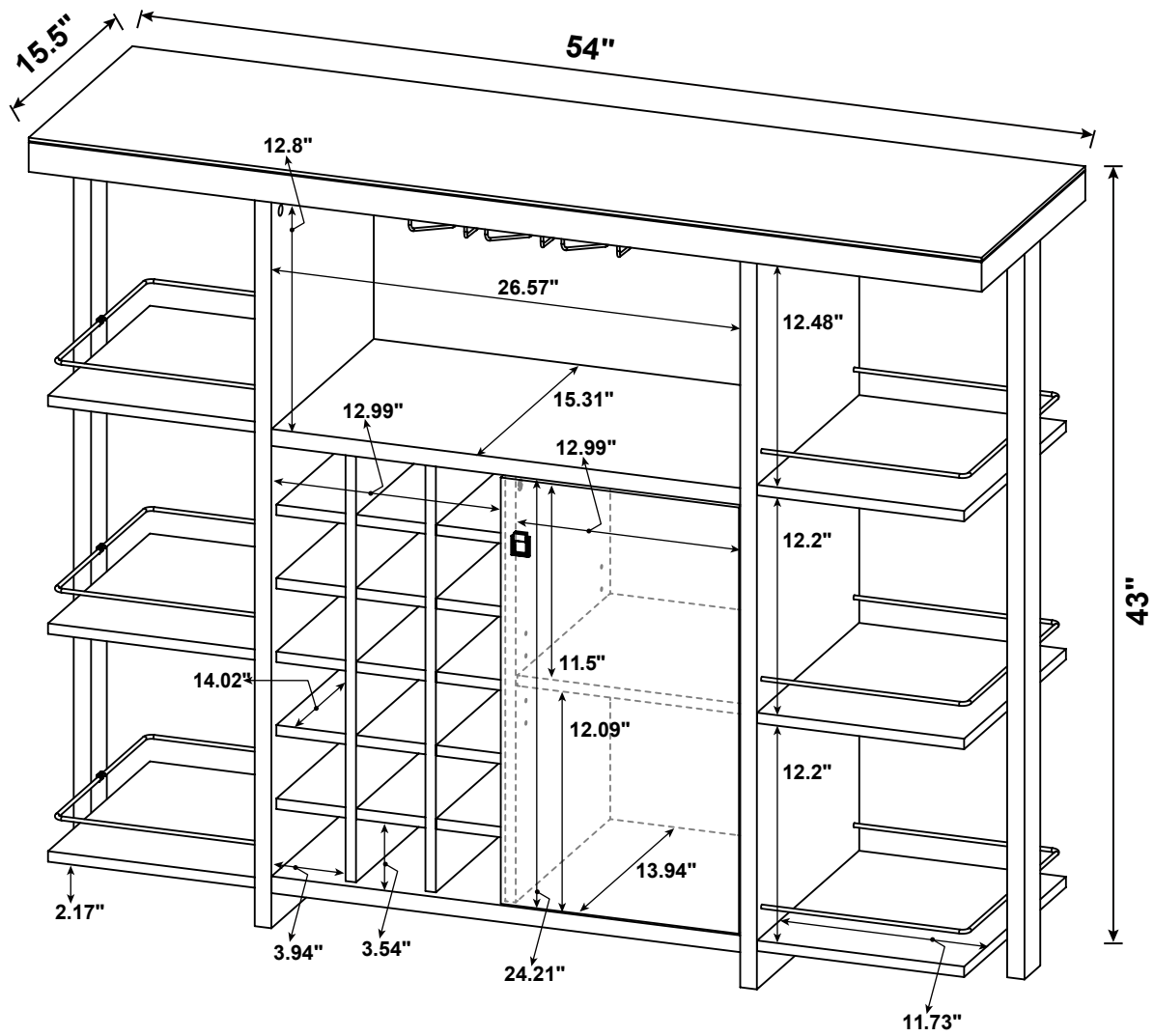

Note : Dimension tolerance  $\pm 5\%$