

ASSEMBLY INSTRUCTIONS
COASTER FINE FURNITURE

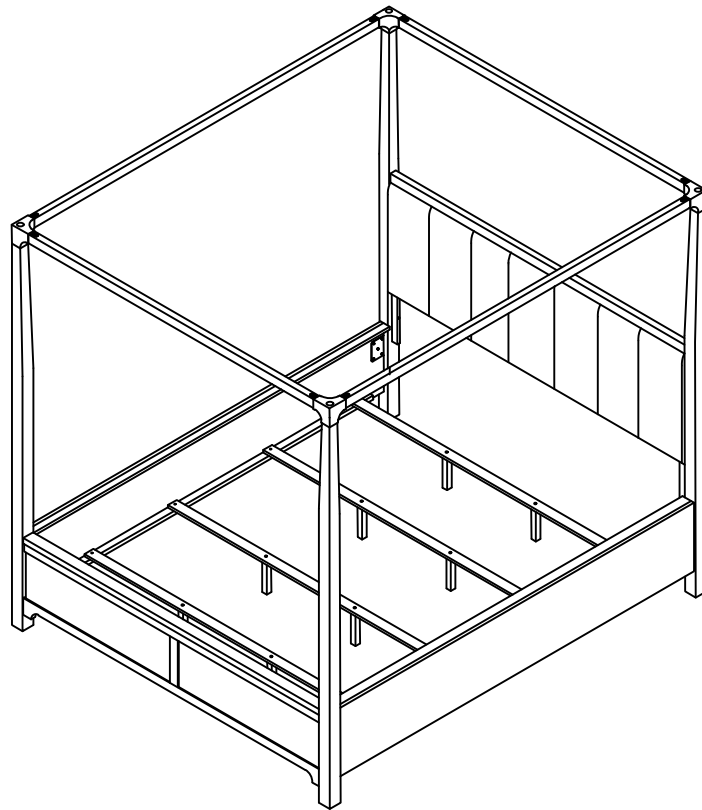

Fine Furniture for every stage of life

224931KW(B1&B2)
California King Bed

ITEM: 224931KW (B1&B2)



ASSEMBLY INSTRUCTIONS

ASSEMBLY TIPS:

1. Remove hardware from box and sort by size.
2. Please check to see that all hardware and parts are present prior to start of assembly.
3. Please follow attached instructions in the same sequence as numbered to assure fast & easy assembly.



WARNING!

1. Don't attempt to repair or modify parts that are broken or defective. Please contact the store immediately.
2. This product is for home use only and not intended for commercial establishments.









ASSEMBLY TIME



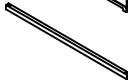

30 MINUTES

PARTS IDENTIFICATION

B1 (BOX 1)

A	HEADBOARD PANEL		1PC
B	FOOTBOARD PANEL		1PC
C	TOP CANOPY BAR		2PCS
D	BED SLAT		4PCS
E	BED SLAT SUPPORT WITH LEVELER		8PCS
F	WOOD CLEAT		2PCS

B2 (BOX 2)

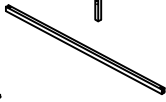
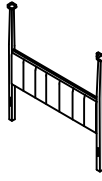
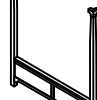
G	BED RAIL		2PCS
H	LEFT HEADBOARD POST		1PC
I	RIGHT HEADBOARD POST		1PC
J	LEFT FOOTBOARD POST		1PC
K	RIGHT FOOTBOARD POST		1PC
L	SIDE CANOPY BAR		2PCS
HB	224931KW (B1&B2) FROM BOX 1&2 HEADBOARD COMPLETE		1PC
FB	224931KW (B1&B2) FROM BOX 1&2 FOOTBOARD COMPLETE		1PC

ITEM: 224931KW (B1&B2)



ASSEMBLY INSTRUCTIONS

ASSEMBLY TIPS:

1. Remove hardware from box and sort by size.
2. Please check to see that all hardware and parts are present prior to start of assembly.
3. Please follow attached instructions in the same sequence as numbered to assure fast & easy assembly.









WARNING!

1. Don't attempt to repair or modify parts that are broken or defective. Please contact the store immediately.
2. This product is for home use only and not intended for commercial establishments.

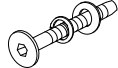
HARDWARE IDENTIFICATION

Z-B2 (BOX 2) - HARDWARE PACK IS LOCATED IN 224931KW (B2)

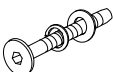
1	ALLEN WRENCH (M4 x 110mm - BLK)		1PC
2	SHORT BOLT (M6 x 25mm - BLK)		8PCS
3	LONG BOLT (M6 x 60mm - BLK)		10PCS
4	WOOD DOWEL (M10 x 40mm)		14PCS
5	SHORT FLAT HEAD SCREW (M3.5 x 16mm - BLK)		20PCS
6	LONG FLAT HEAD SCREW (#8 x 1 1/8" - BLK)		8PCS
7	BRACKET (35H x 18W x 35Lmm - BLK)		8PCS
8	MEDIUM BOLT (M6 x 50mm - BLK)		2PCS

NOTE:

Phillips head screw driver is required in the assembly process; however, manufacturer does not provide this item.

ITEM: 224931KW (B1&B2)



ASSEMBLY INSTRUCTIONS

STEP 1

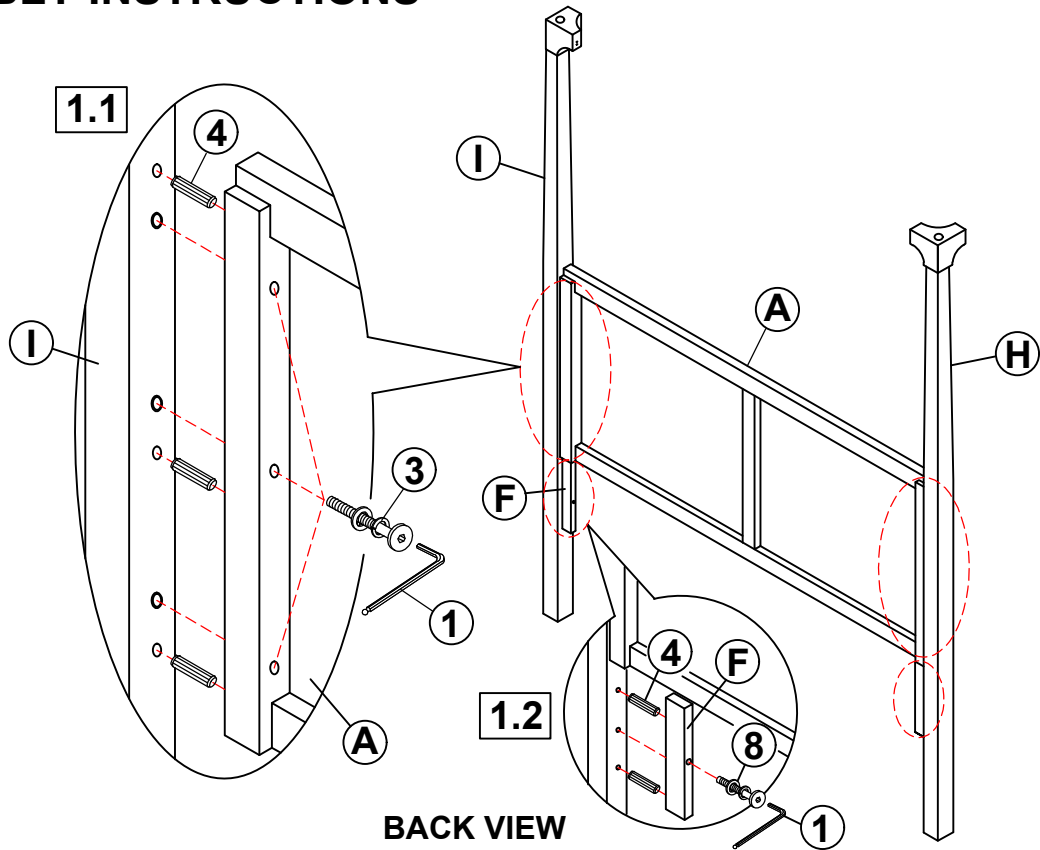

BACK VIEW

STEP 2

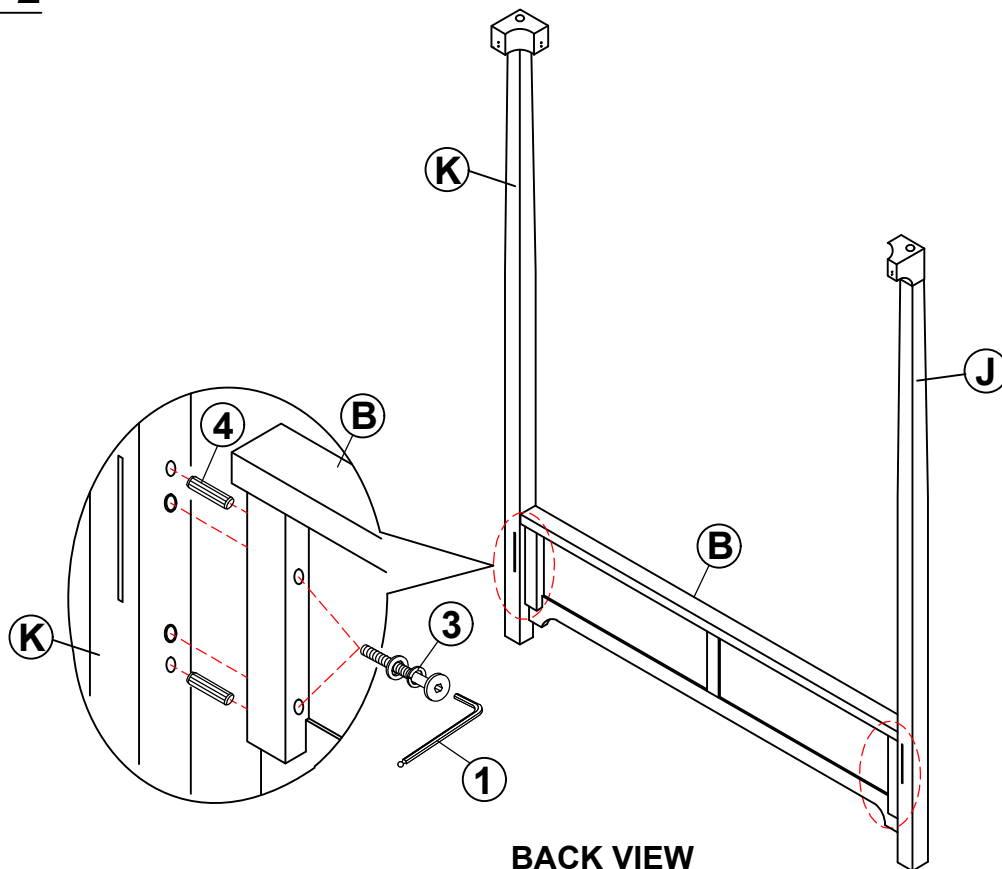

BACK VIEW

ITEM: **224931KW (B1&B2)**



ASSEMBLY INSTRUCTIONS

STEP 3

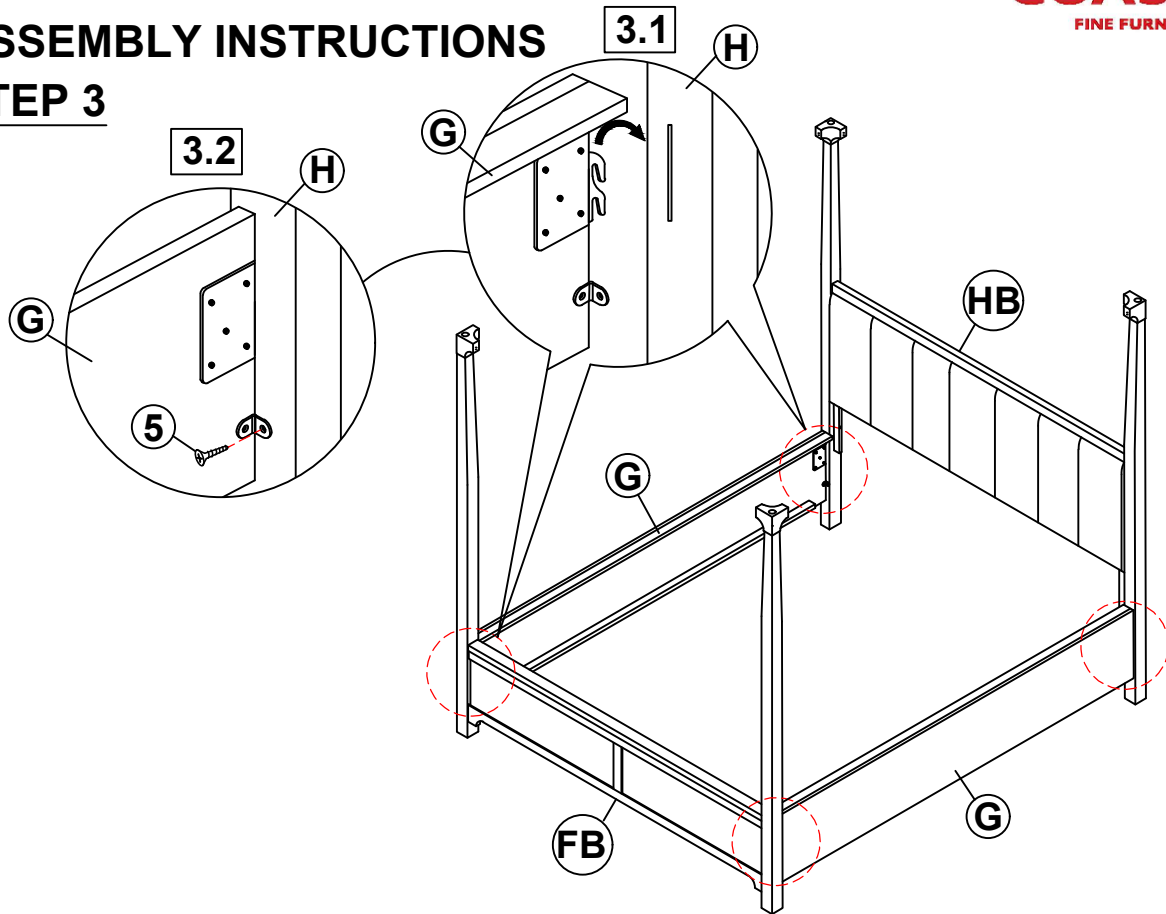

STEP 4

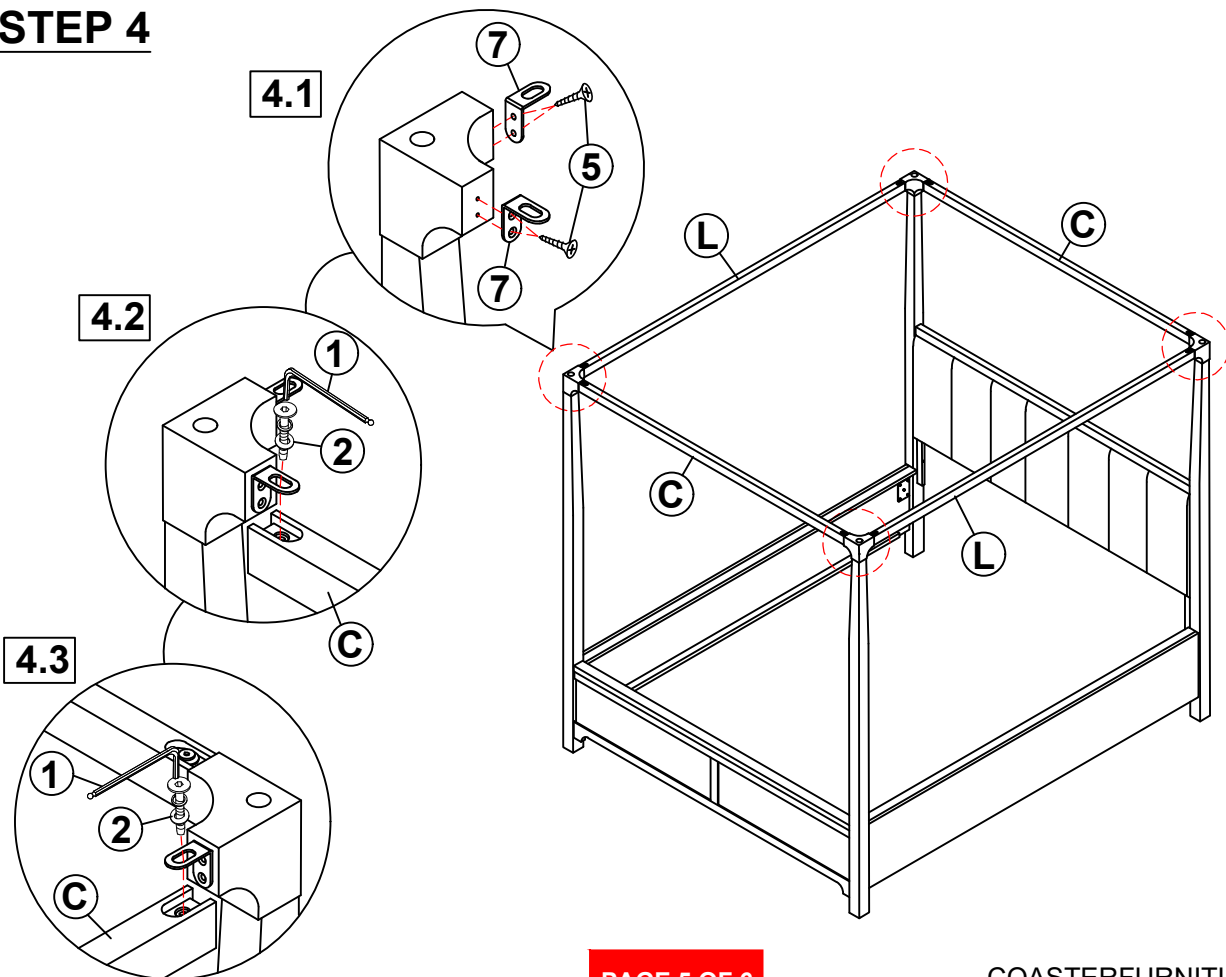

ITEM: **224931KW (B1&B2)**



ASSEMBLY INSTRUCTIONS
STEP 5

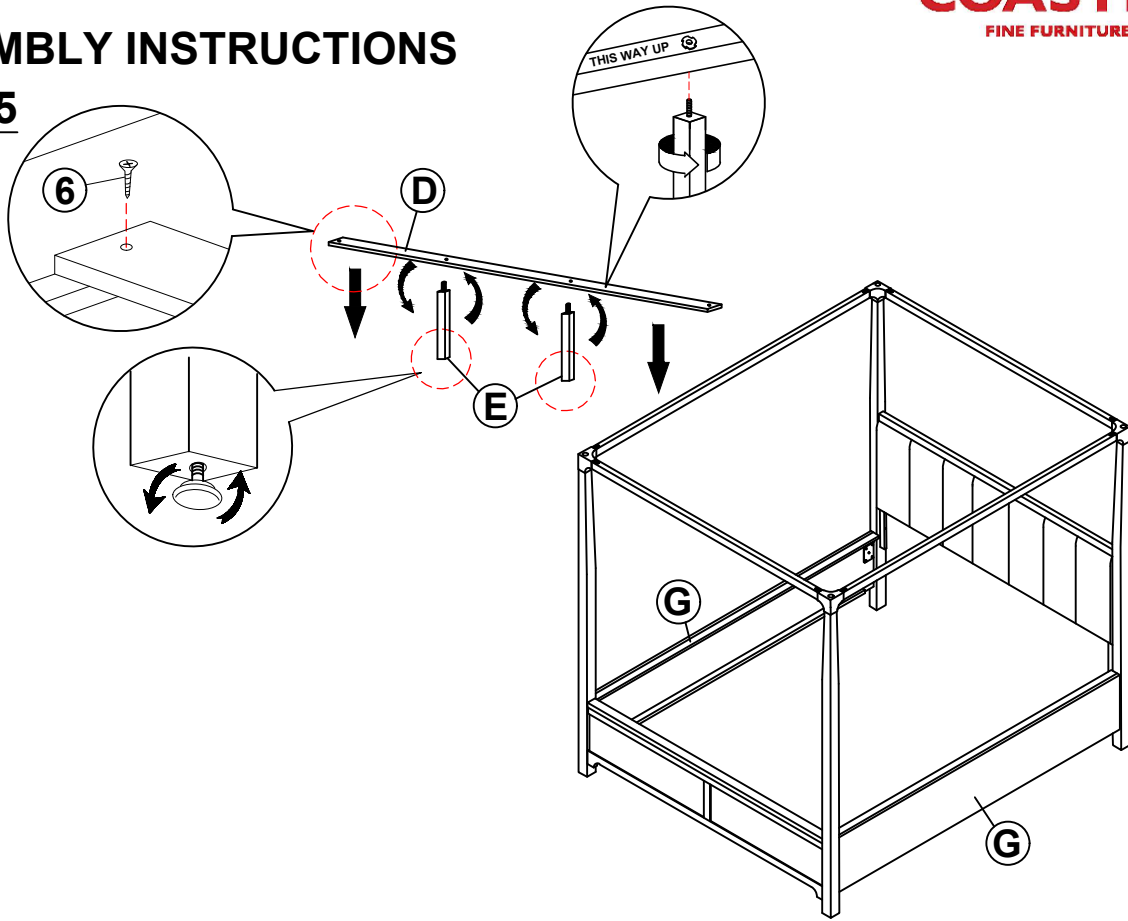

STEP 6
COMPLETE

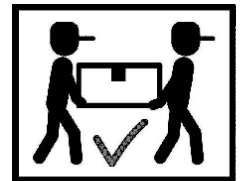
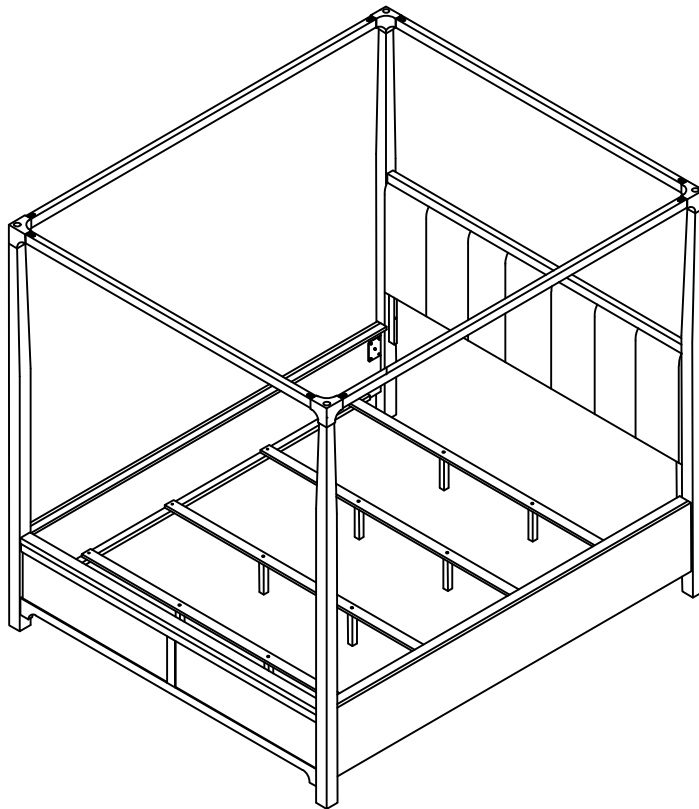

ITEM: **224931KW (B1&B2)**



Inner Size : 73.25"W x 85.00"D

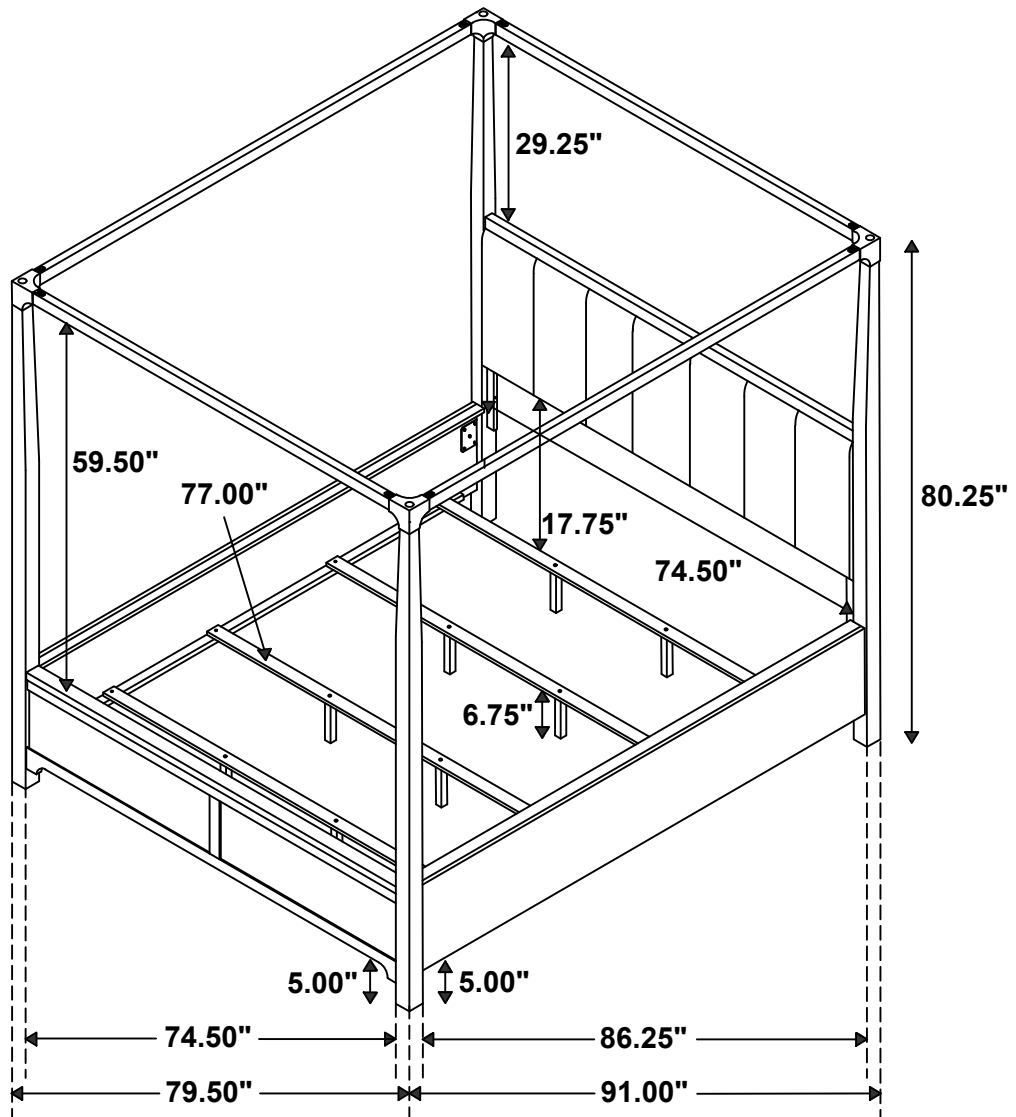

Note : Dimension tolerance $\pm 5\%$