



ASSEMBLY INSTRUCTIONS COASTER FINE FURNITURE



801941
OFFICE CHAIR

ITEM:801941



ASSEMBLY INSTRUCTIONS

ASSEMBLY TIPS:

1. Remove hardware from box and sort by size.
2. Please check to see that all hardware and parts are present prior to start of assembly.
3. Please follow attached instructions in the same sequence as numbered to assure fast & easy assembly.











WARNING!

1. Don't attempt to repair or modify parts that are broken or defective. Please contact the store immediately.
2. This product is for home use only and not intended for commercial establishments.







ASSEMBLY TIME

5 MINUTES

PARTS IDENTIFICATION

A		SEAT	1PC
B		BACKREST	1PC
C		LEFT ARMREST	1PC
D		RIGHT ARMREST	1PC
E		ADJUSTING PLATE	1PC
F		GAS LIFT	1PC
G		BASE	1PC
H		CASTOR	5PCS

HARDWARE IDENTIFICATION

NO	DESCRIPTION	FIGURE	QTY
1	BLOT (M6*20mm - BLK)		4PCS
2	BLOT (M8*20mm - BLK)		6PCS
3	BLOT (M6*25mm - BLK)		3PCS
4	FLAT WASHER (M8*22mm*1.4mm - BLK)		3PCS
5	FLAT WASHER (M6*18mm*1.2mm - BLK)		10PCS
6	ALLEN WERNCH (M6 - BLK)		1PC
7	CAP		1PC

ITEM:801941

ASSEMBLY INSTRUCTIONS



STEP 1

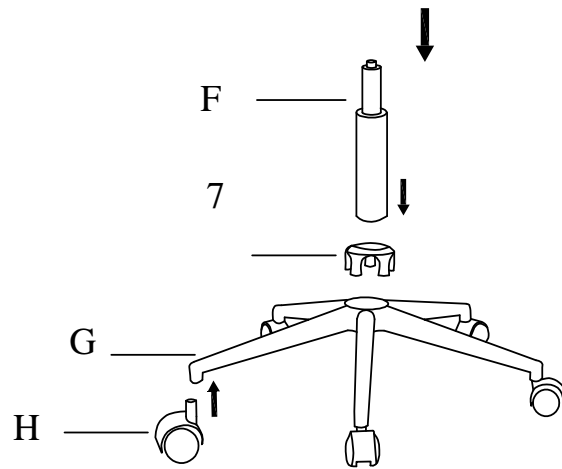

STEP 2

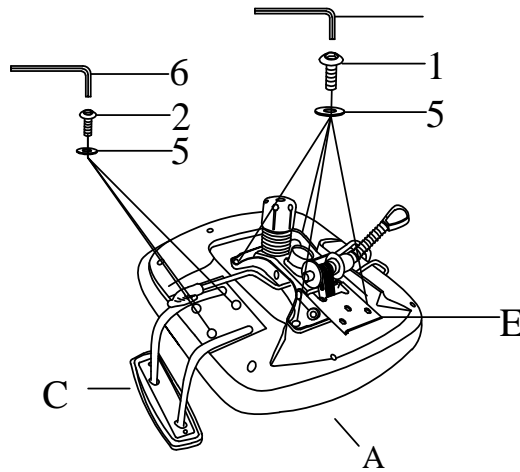

STEP 3

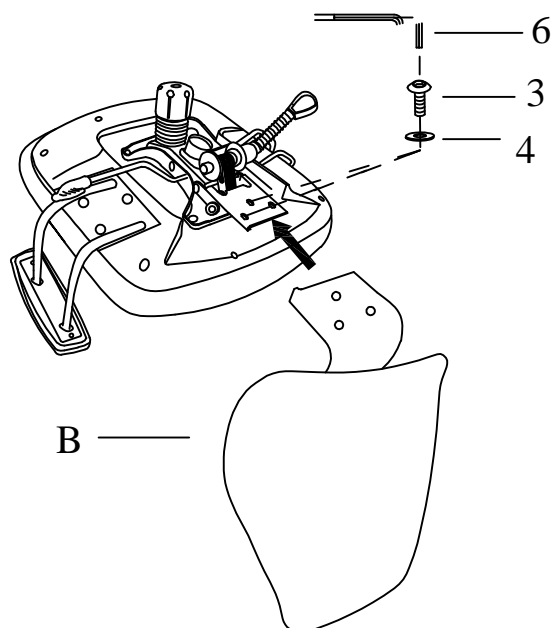

COASTERFURNITURE.COM

ITEM:801941

ASSEMBLY INSTRUCTIONS



STEP 4



STEP 5



COASTERFURNITURE.COM

