

ASSEMBLY INSTRUCTIONS
COASTER FINE FURNITURE



Fine Furniture for every stage of life

115530(B1&B2)
Dining Table

ITEM: 115530(B1&B2)



ASSEMBLY INSTRUCTIONS

ASSEMBLY TIPS:

1. Remove hardware from box and sort by size.
2. Please check to see that all hardware and parts are present prior to start of assembly.
3. Please follow attached instruction in the same sequence as numbered to assure fast and easy assembly.



WARNING !

1. Don't attempt to repair or modify parts that are broken or defective. Please contact the store immediately.
2. This product is for home use only and not intended for commercial establishment.



ASSEMBLY TIME

20 MINUTES

PARTS IDENTIFICATION

B1 (BOX 1)

A TOP

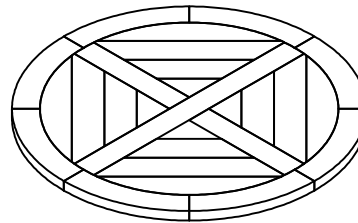

1PC

B2 (BOX 2)

B PEDESTAL COLUMN



1PC

C UPPER MOUNTING BAR

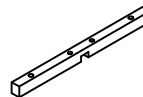

1PC

D LOWER MOUNTING BAR

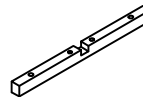

1PC

E UPPER BASE

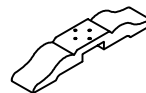

1PC

F LOWER BASE

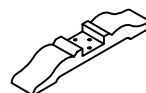

1PC

ITEM: 115530(B1&B2)

ASSEMBLY INSTRUCTIONS

ASSEMBLY TIPS:

1. Remove hardware from box and sort by size.
2. Please check to see that all hardware and parts are present prior to start of assembly.
3. Please follow attached instruction in the same sequence as numbered to assure fast and easy assembly.







WARNING !

1. Don't attempt to repair or modify parts that are broken or defective. Please contact the store immediately.
2. This product is for home use only and not intended for commercial establishment.

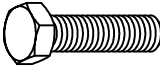
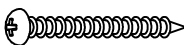
HARDWARE IDENTIFICATION

Z-B1 (BOX 1) - HARWARE PACK IS LOCATED IN 115530 (B1)

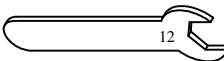
1	LONG BOLT (M8 x 70mm - RBW)		4PCS
2	SHORT BOLT (M8 x 50mm - RBW)		4PCS
3	PAN HEAD SCREW (4 x 44mm - SR)		4PCS
4	LOCK WASHER (M8 - SR)		12PCS
5	FLAT WASHER (M8 - RBW)		12PCS
6	THREADED BOLT (M8 x 135mm - BLK)		4PCS
7	HEX NUT (M8 x 12 - RBW)		4PCS
8	WRENCH (M12 - SR)		1PC

NOTE:

Phillips head screw driver is required in the assembly process; however, manufacturer does not provide this item.

ITEM: 115530(B1&B2)

ASSEMBLY INSTRUCTIONS

STEP 1

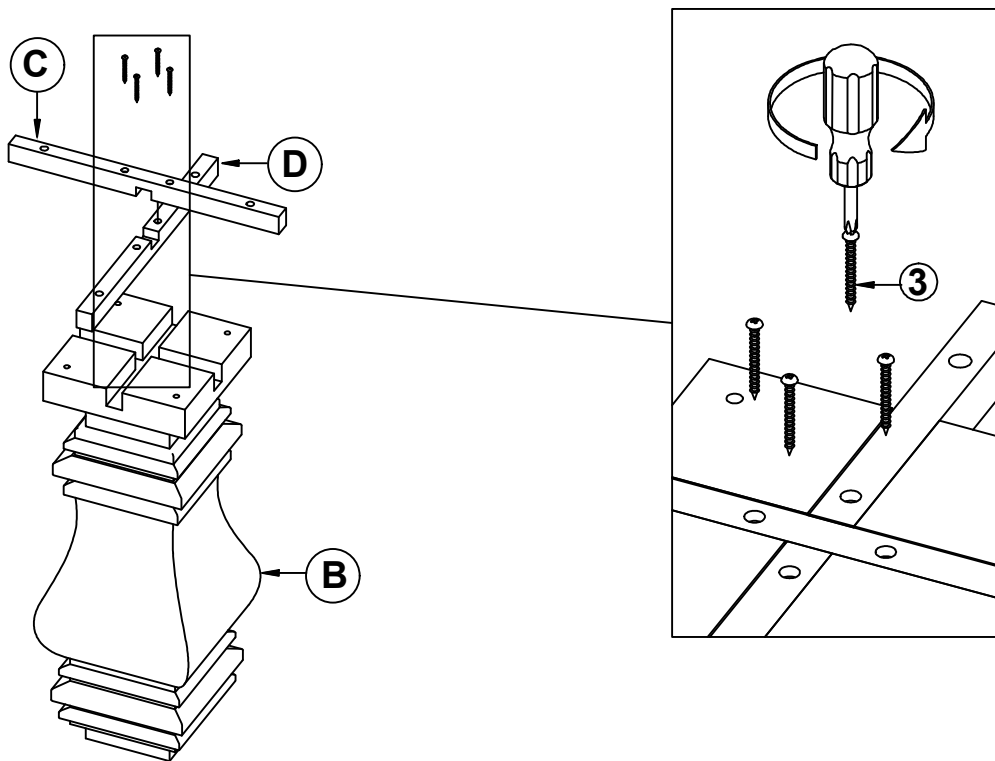

STEP 2

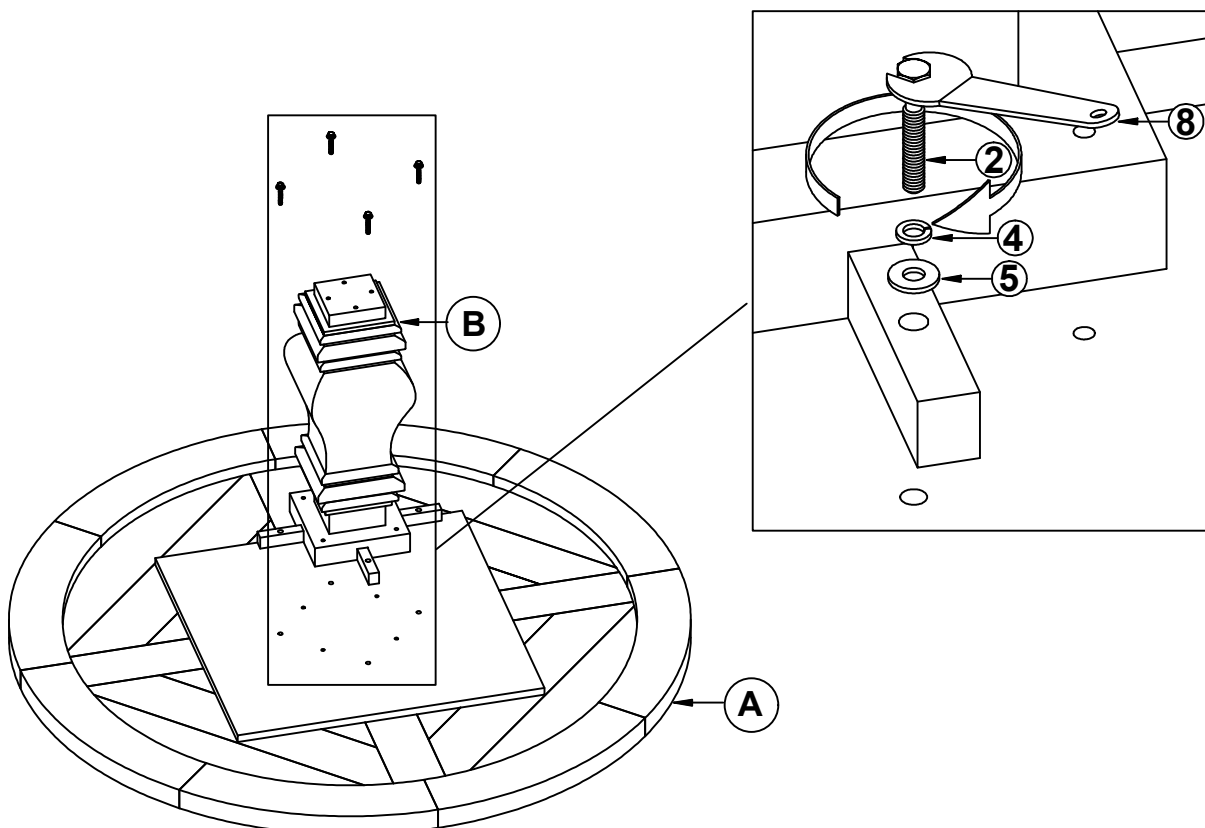

ITEM: 115530(B1&B2)

ASSEMBLY INSTRUCTIONS

STEP 3

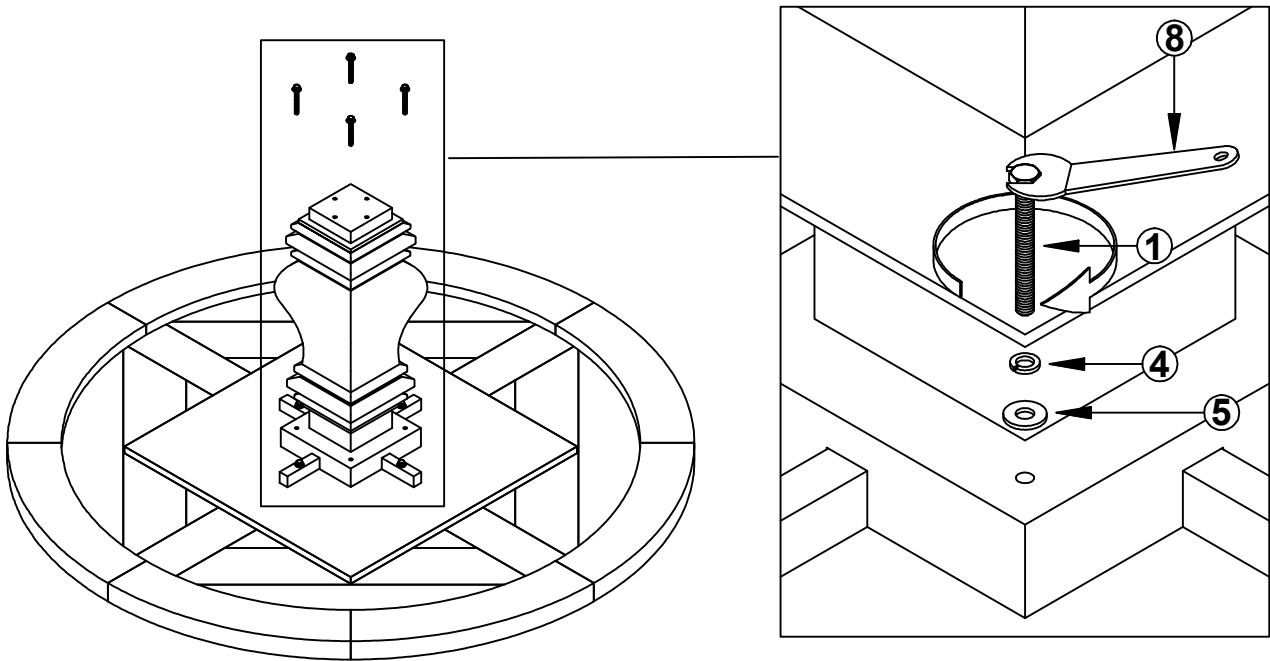

STEP 4

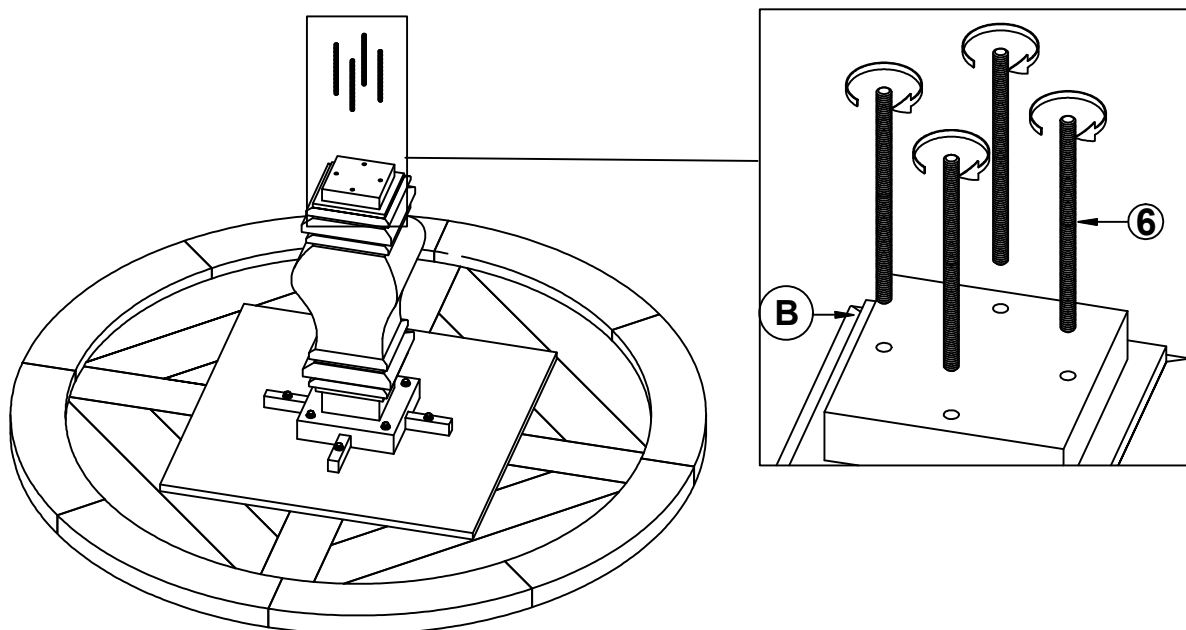

ITEM: 115530(B1&B2)

ASSEMBLY INSTRUCTIONS

STEP 5

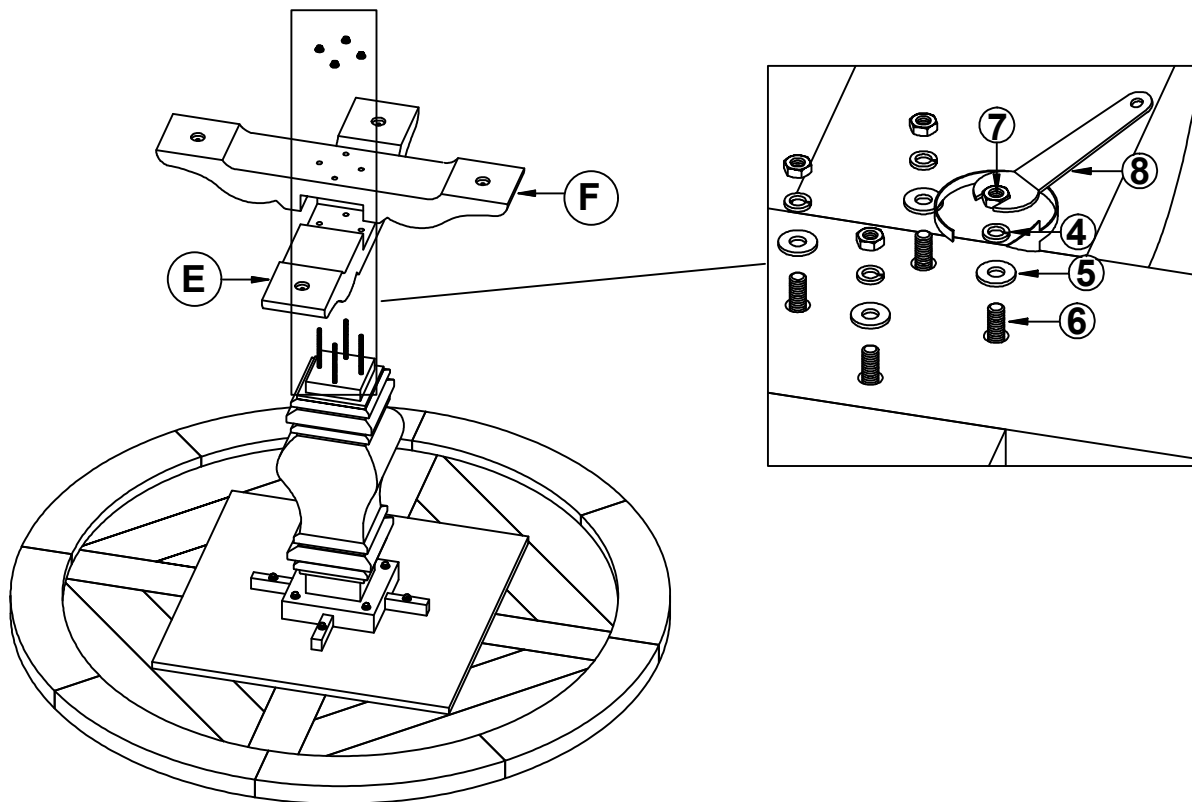

STEP 6

COMPLETE

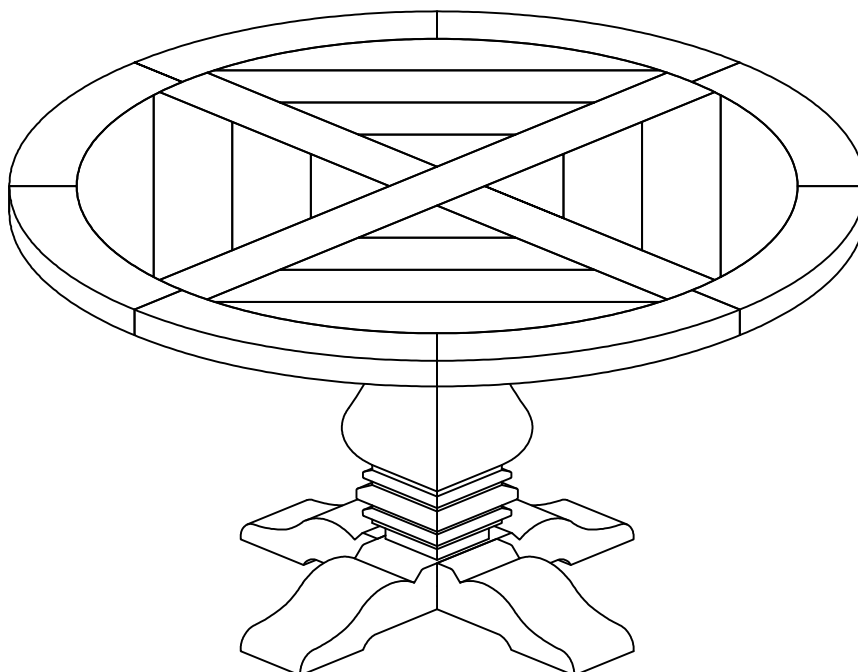

ITEM: **115530(B1&B2)**

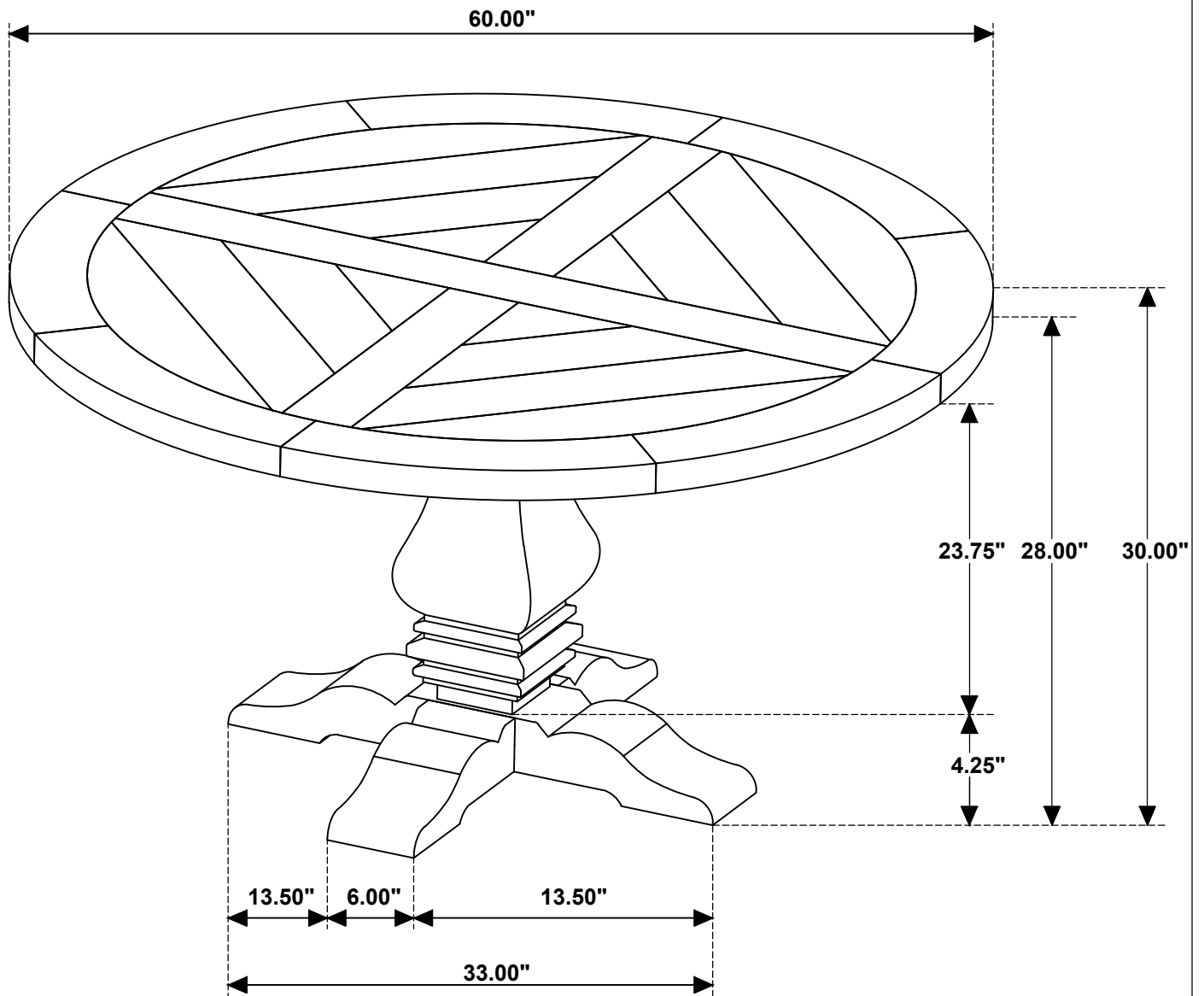

Note : Dimension tolerance $\pm 5\%$