

*ASSEMBLY INSTRUCTIONS*  
*COASTER FINE FURNITURE*



*Fine Furniture for every stage of life*

**115562**  
***Side Chair***

ITEM: **115562**

## ASSEMBLY INSTRUCTIONS

### ASSEMBLY TIPS:

1. Remove hardware from box and sort by size.
2. Please check to see that all hardware and parts are present prior to start of assembly.
3. Please follow attached instruction in the same sequence as numbered to assure fast and easy assembly.



### WARNING !



1. Don't attempt to repair or modify parts that are broken or defective. Please contact the store immediately.
2. This product is for home use only and not intended for commercial establishment.





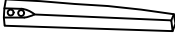

ASSEMBLY TIME

15 MINUTES

## PARTS IDENTIFICATION

A	SEAT AND BACK		1PC
B	FRONT LEG		2PCS
C	BACK LEG		2PCS

## HARDWARE IDENTIFICATION

1	LONG BOLT (M8 x 60mm - BLK)		4PCS
2	SHORT BOLT (M8 x 50mm - BLK)		4PCS
3	LOCK WASHER (M8 - BLK)		8PCS
4	FLAT WASHER (M8 - BLK)		8PCS
5	ALLEN WRENCH (M5 - BLK)		1PC

ITEM: **115562**  
**ASSEMBLY INSTRUCTIONS**

**STEP 1**

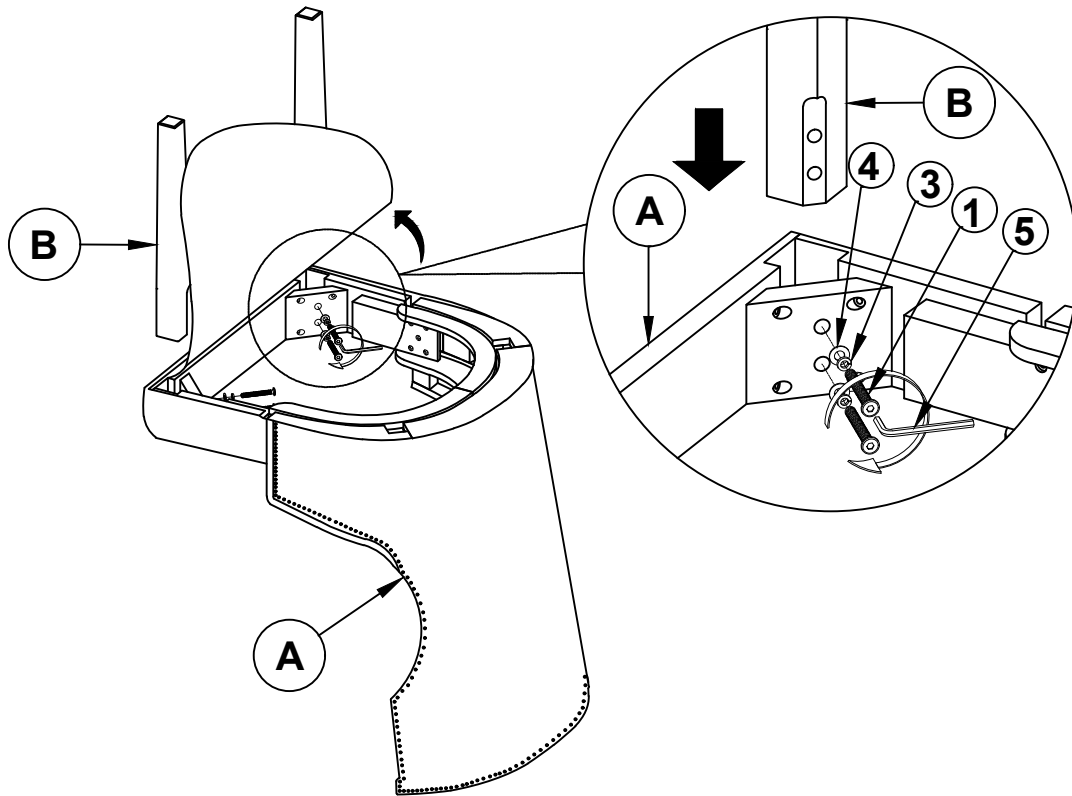

**STEP 2**

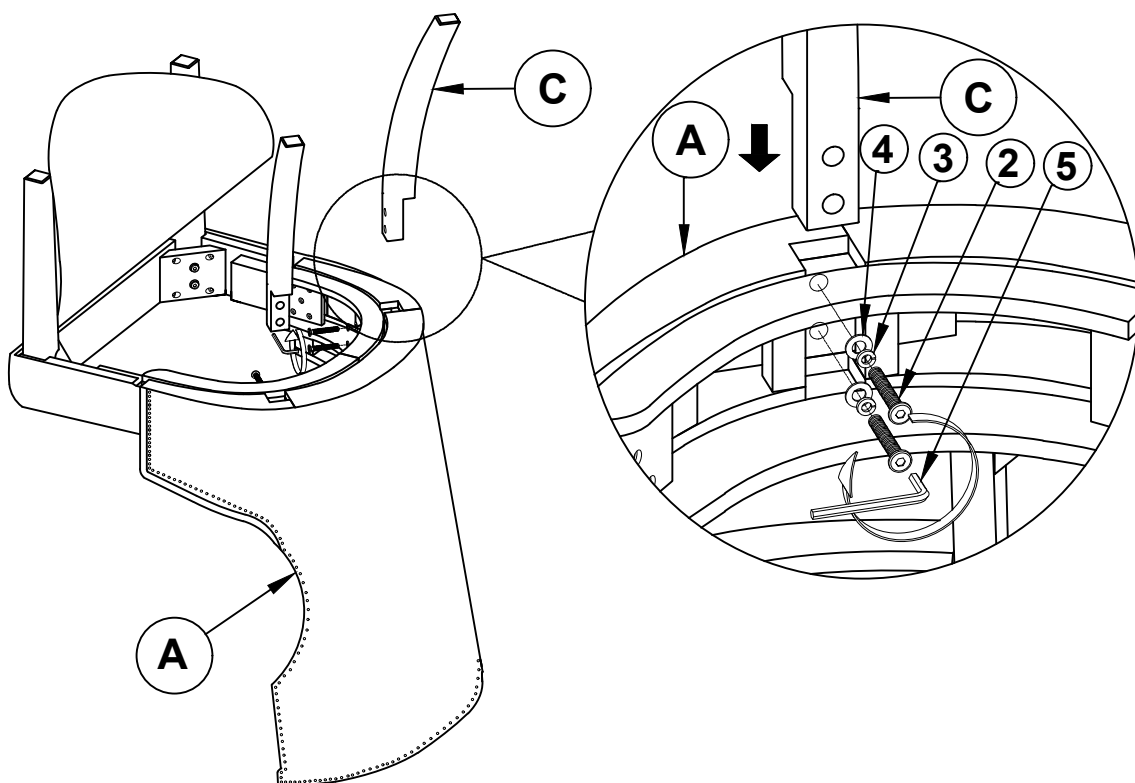

ITEM: **115562**  
**ASSEMBLY INSTRUCTIONS**



**STEP 3**  
**COMPLETE**

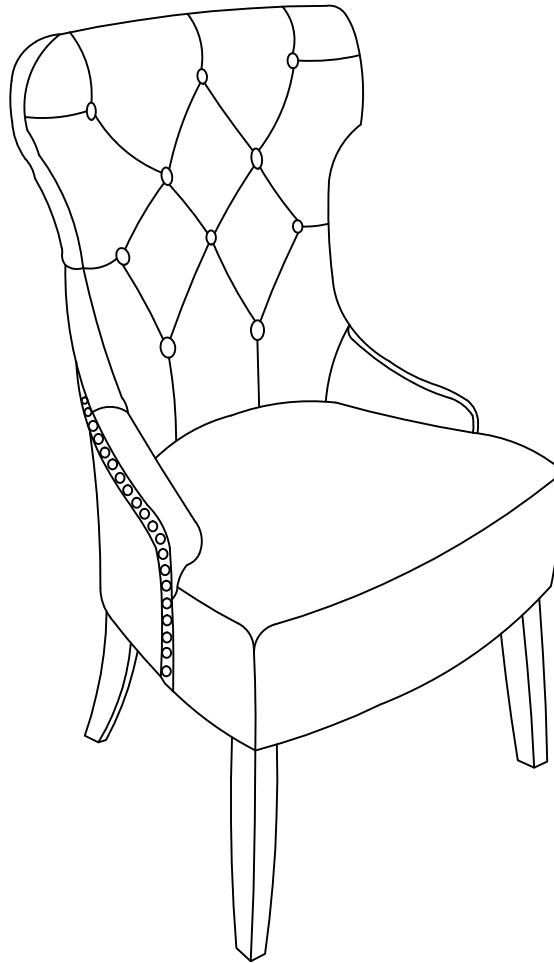

ITEM: 115562

**COASTER**  
FINE FURNITURE

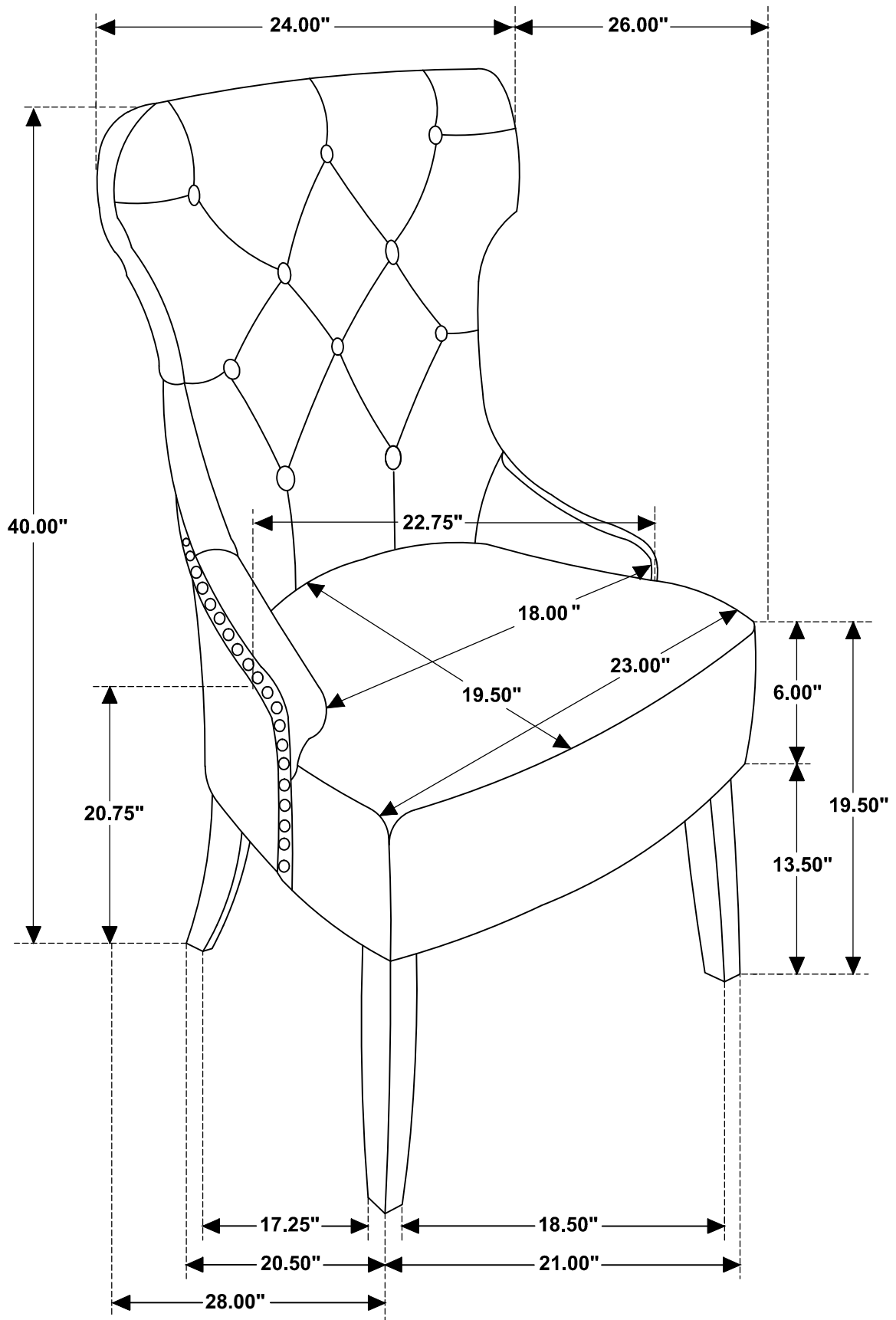

Note : Dimension tolerance  $\pm$  5%