

ASSEMBLY INSTRUCTIONS
COASTER FINE FURNITURE

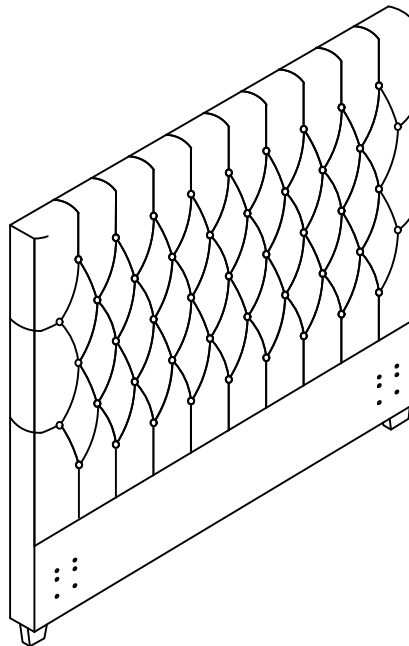

Fine Furniture for every stage of life

300007KW(B1)
California King Headboard

ITEM: 300007KW(B1)



ASSEMBLY INSTRUCTIONS

ASSEMBLY TIPS:

1. Remove hardware from box and sort by size.
2. Please check to see that all hardware and parts are present prior to start of assembly.
3. Please follow attached instructions in the same sequence as numbered to assure fast & easy assembly.



WARNING!

1. Don't attempt to repair or modify parts that are broken or defective. Please contact the store immediately.
2. This product is for home use only and not intended for commercial establishments.



ASSEMBLY TIME

15 MINUTES

PARTS IDENTIFICATION

B1 (BOX 1)

AV HEADBOARD PANEL

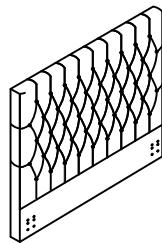

1PC

BV HEADBOARD LEG



2PCS

HARDWARE IDENTIFICATION

Z-B1(BOX1) - HARDWARE PACK IS LOCATED IN 300007KW(B1)

1	ALLEN WRENCH (5mm - RBW)		1PC	2	FLAT WASHER (Ø5/16" - RBW)		2PCS
3	BOLT (Ø5/16" x 70mm - RBW)		2PCS				
9	HEX NUT (6mm x 13mm x 13 - RBW)		6PCS	10	WRENCH (14mm - RBW)		1PC
11	BOLT (Ø1/4" x 38mm - RBW)		6PCS	12	SMALL LOCK WASHER (Ø1/4" - RBW)		12PCS
13	SMALL FLAT WASHER (Ø1/4" - RBW)		12PCS				

ITEM: **300007KW(B1)**

ASSEMBLY INSTRUCTIONS



STEP 1

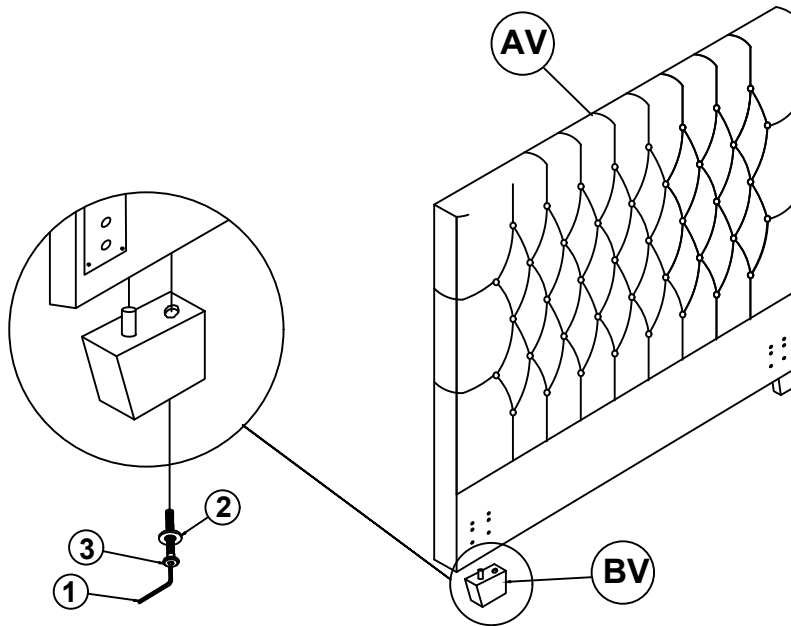

STEP 2
COMPLETE

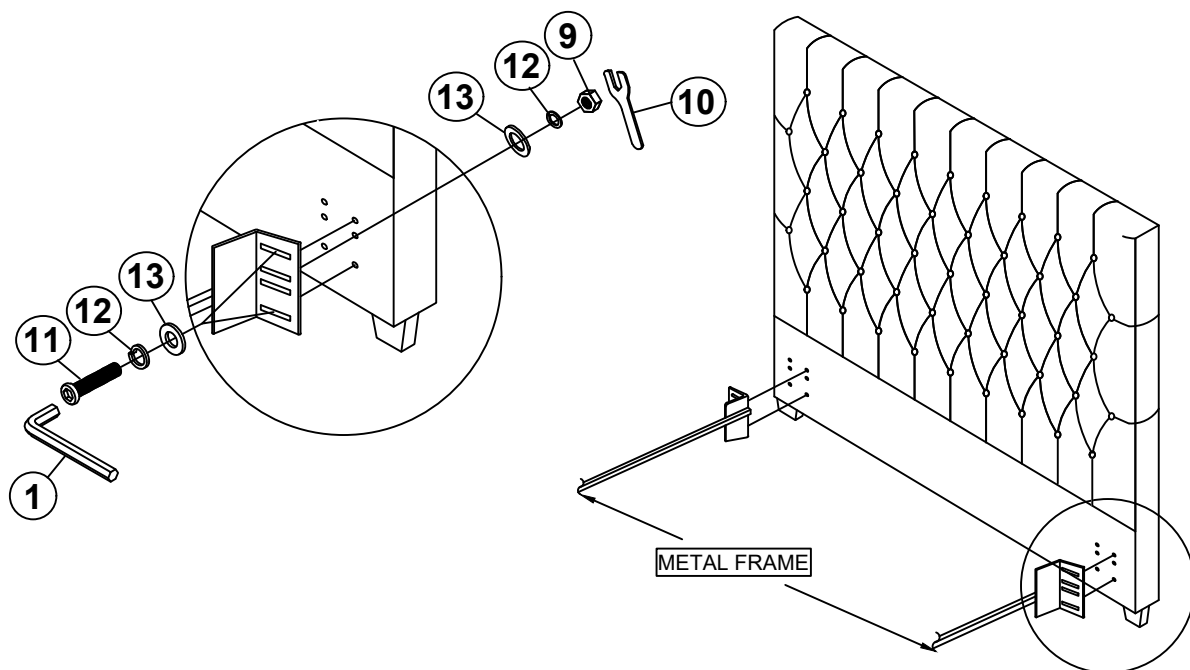

ITEM: **300007KW(B1)**



Inner Size: 73.00"W X 81.25"D

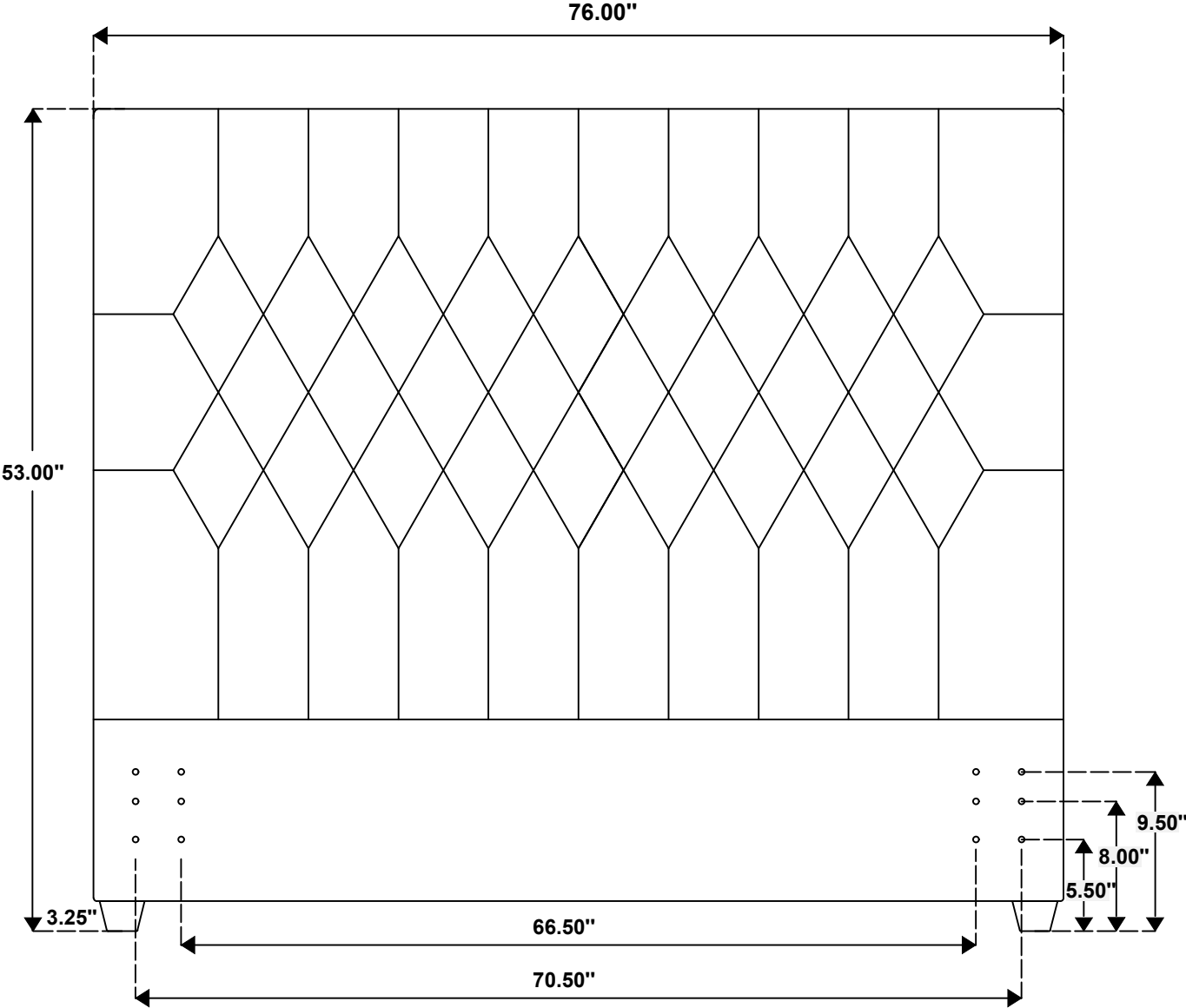

Note: Dimension tolerance $\pm 5\%$