

ASSEMBLY INSTRUCTIONS
COASTER FINE FURNITURE

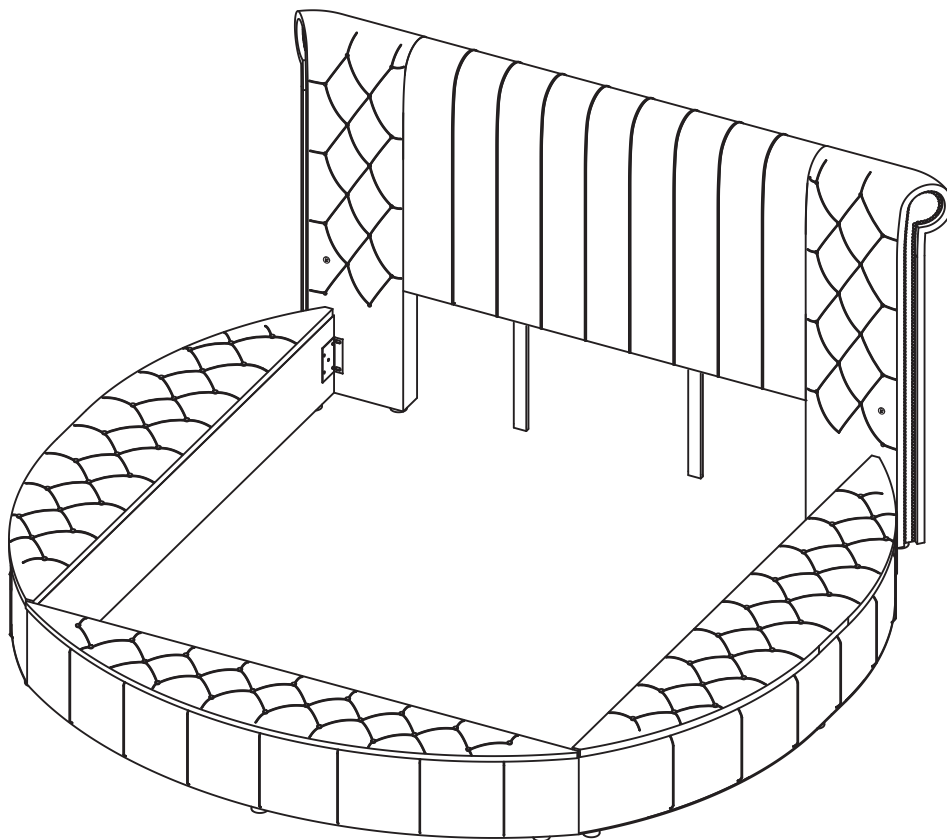

Fine Furniture for every stage of life

360111Q(B1-B5)
Queen Bed

ITEM: 360111Q(B1-B5)



ASSEMBLY INSTRUCTIONS

ASSEMBLY TIPS :

1. Remove hardware from box and sort by size.
2. Please check to see that all hardware and parts are present prior to start of assembly.
3. Please follow attached instructions in the same sequence as numbered to assure fast & easy assembly.



WARNING !

1. Don't attempt to repair or modify parts that are broken or defective. Please contact the store immediately.
2. This product is for home use only and not intended for commercial establishments.



ASSEMBLY TIME

35 MINUTES

PARTS IDENTIFICATION

B1 (BOX 1)

A HEADBOARD PANEL

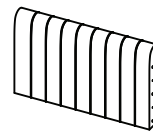

1PC

B HEADBOARD SUPPORT



2PCS

B2 (BOX 2)

C LEFT WING



1PC

D RIGHT WING



1PC

B3 (BOX 3)

E STORAGE FOOTBOARD

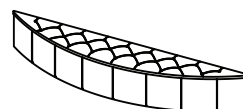

1PC

F FEET



9PCS

B4 (BOX 4)

G LEFT BED RAIL STORAGE

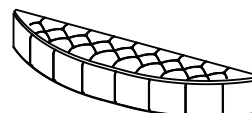

1PC

B5 (BOX 5)

H RIGHT BED RAIL STORAGE

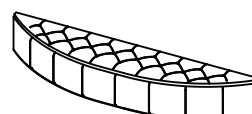

1PC

NOTE:

Phillips head screw driver is required in the assembly process; however, manufacturer does not provide this item.

ITEM: 360111Q(B1-B5)



ASSEMBLY INSTRUCTIONS

ASSEMBLY TIPS :

1. Remove hardware from box and sort by size.
2. Please check to see that all hardware and parts are present prior to start of assembly.
3. Please follow attached instructions in the same sequence as numbered to assure fast & easy assembly.









WARNING !

1. Don't attempt to repair or modify parts that are broken or defective. Please contact the store immediately.
2. This product is for home use only and not intended for commercial establishments.

HARDWARE IDENTIFICATION

Z-B3 (BOX 3) - HARDWARE PACK IS LOCATED IN 360111Q(B3)

1	ALLEN WRENCH (Φ4 X 95mm- ZINC)		1PC
2	BOLT (Φ6 X 35mm - RBW)		18PCS
3	FLAT HEAD SCREW (Φ4 X 32mm - RBW)		9PCS
4	LOCK WASHER (Φ6 - RBW)		18PCS
5	FLAT WASHER (Φ7 X 19mm X 2.0 - RBW)		18PCS
6	PLASTIC DOWEL (Φ8 X 30MM)		4PCS

NOTE:

Phillips head screw driver is required in the assembly process; however, manufacturer does not provide this item.

ASSEMBLY INSTRUCTIONS

STEP 1

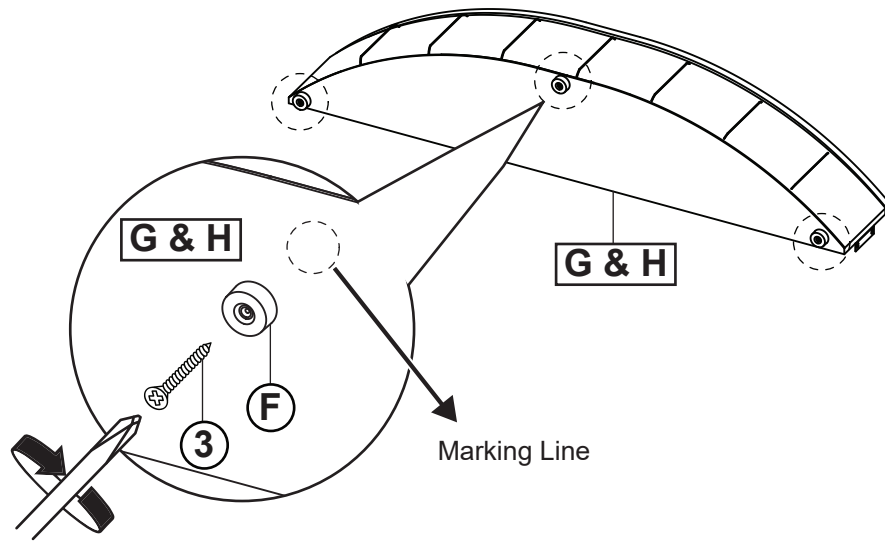

STEP 2

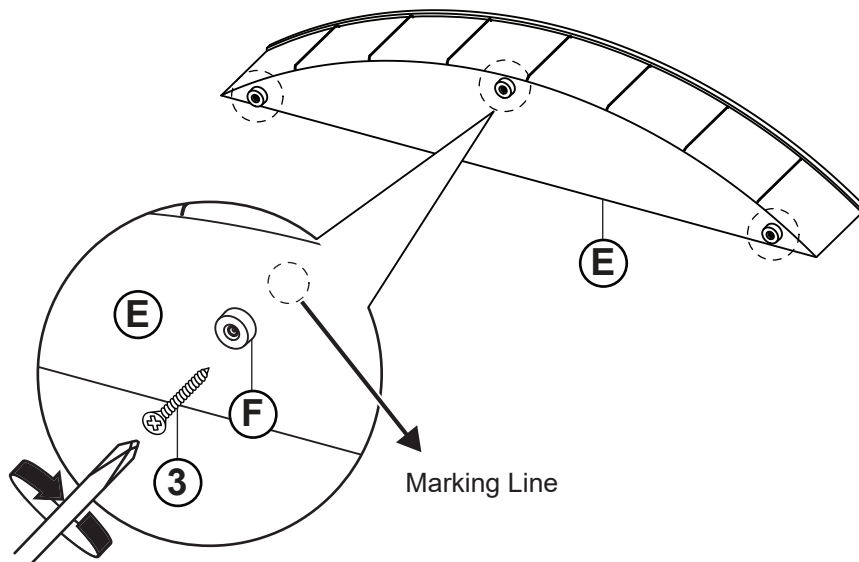

STEP 3

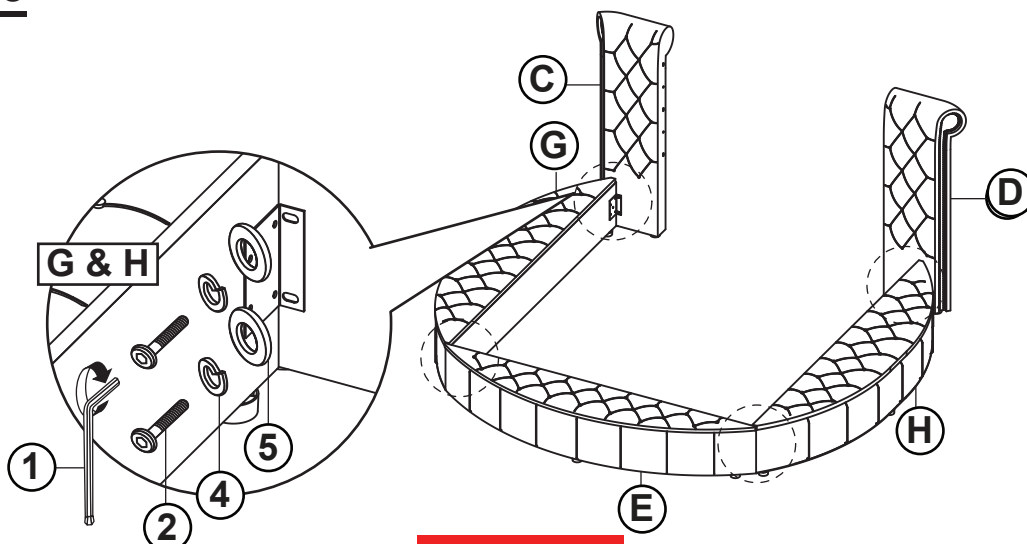

ITEM: 360111Q(B1-B5)



ASSEMBLY INSTRUCTIONS

STEP 4

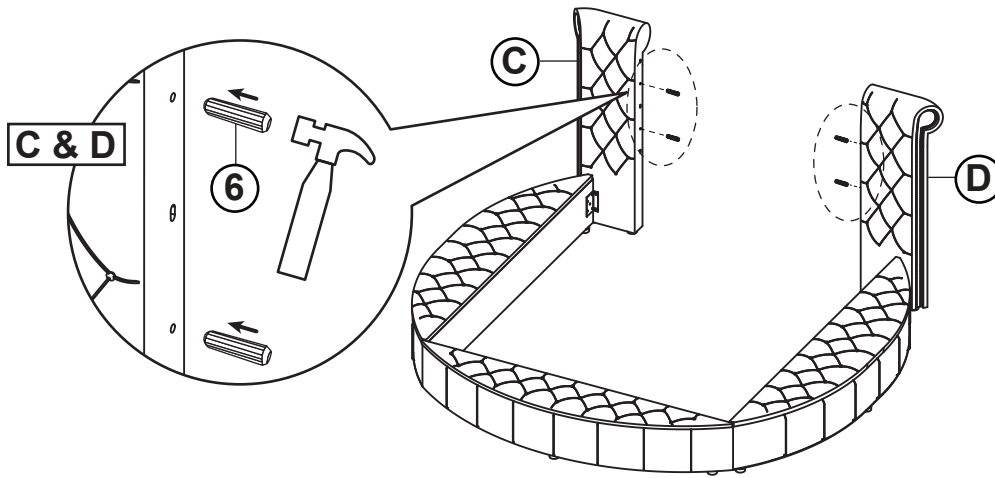

STEP 5

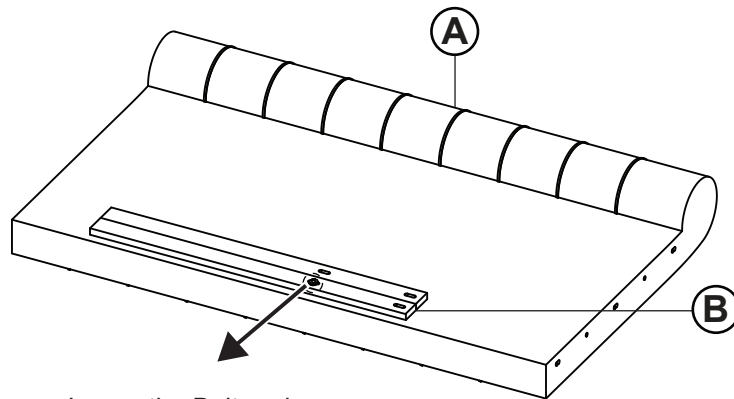

Loose the Bolt and remove the Headboard Support (B).

STEP 6

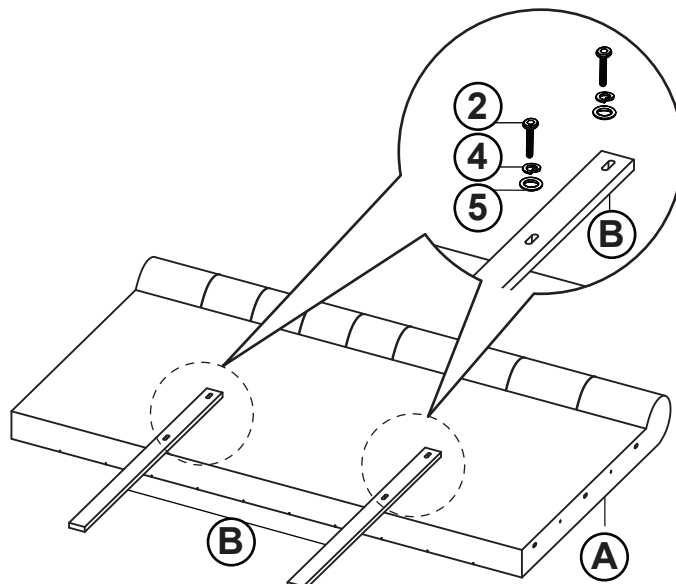

Hand Tighten all the Bolts.

ITEM: 360111Q(B1-B5)



ASSEMBLY INSTRUCTIONS

STEP 7

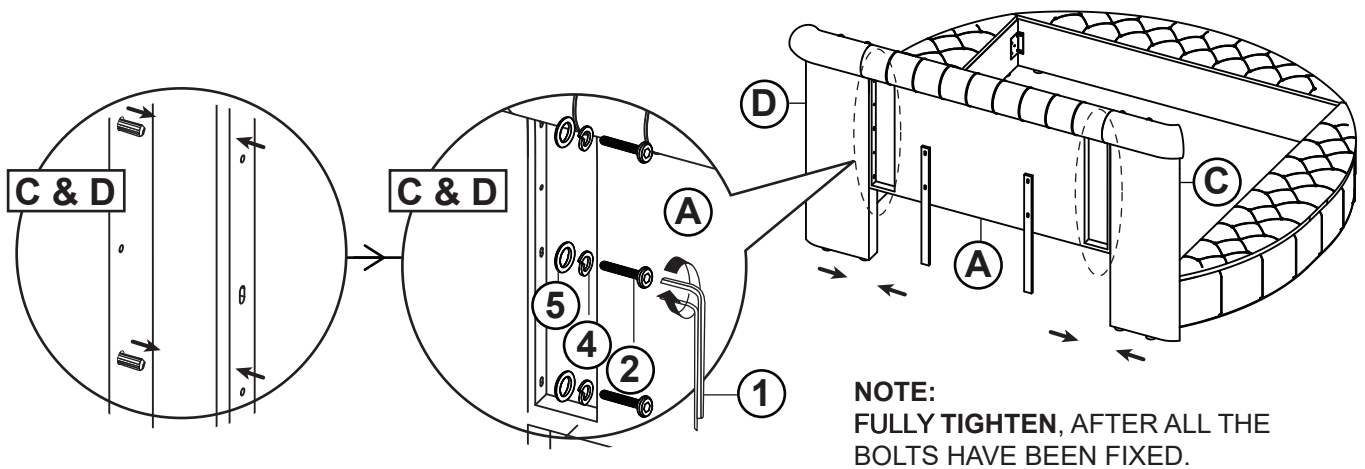

STEP 8

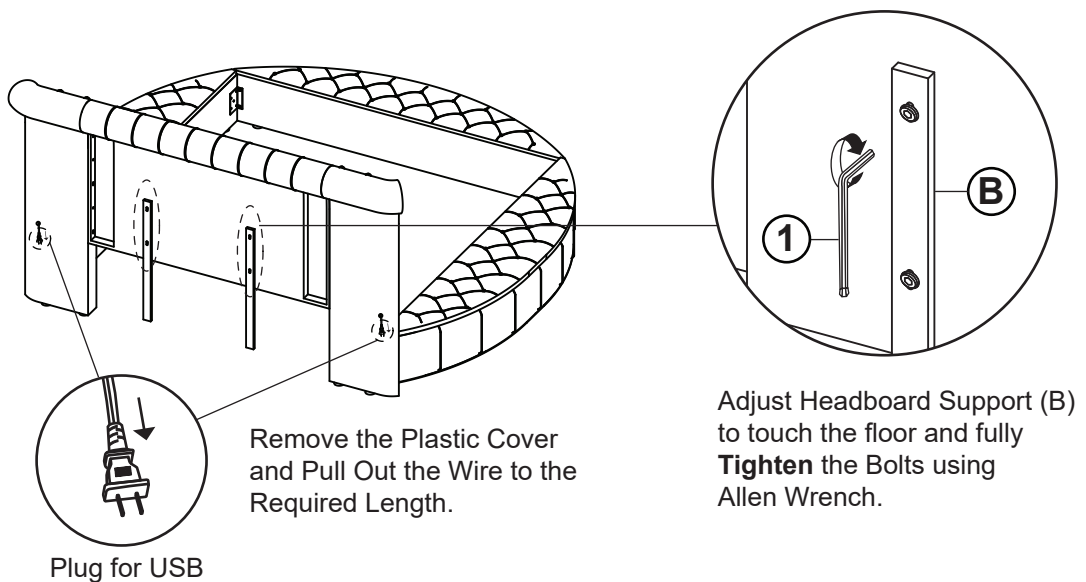

STEP 9 **COMPLETE**

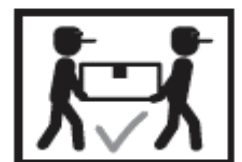
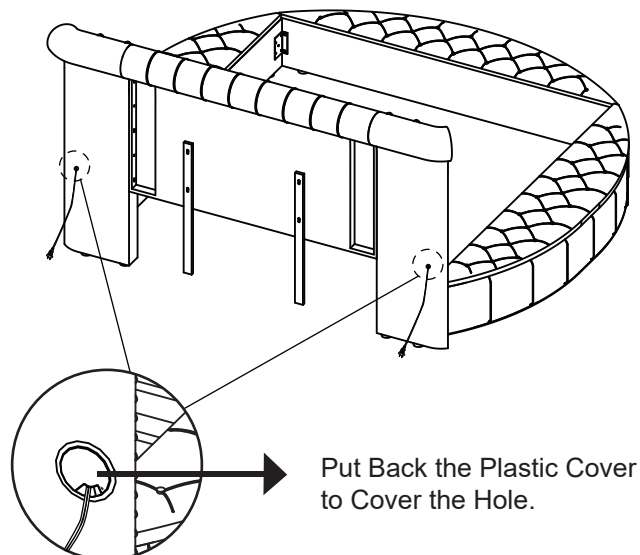

ITEM: 360111Q(B1-B5)



Inner Size : 61.00"W x 82.00"D

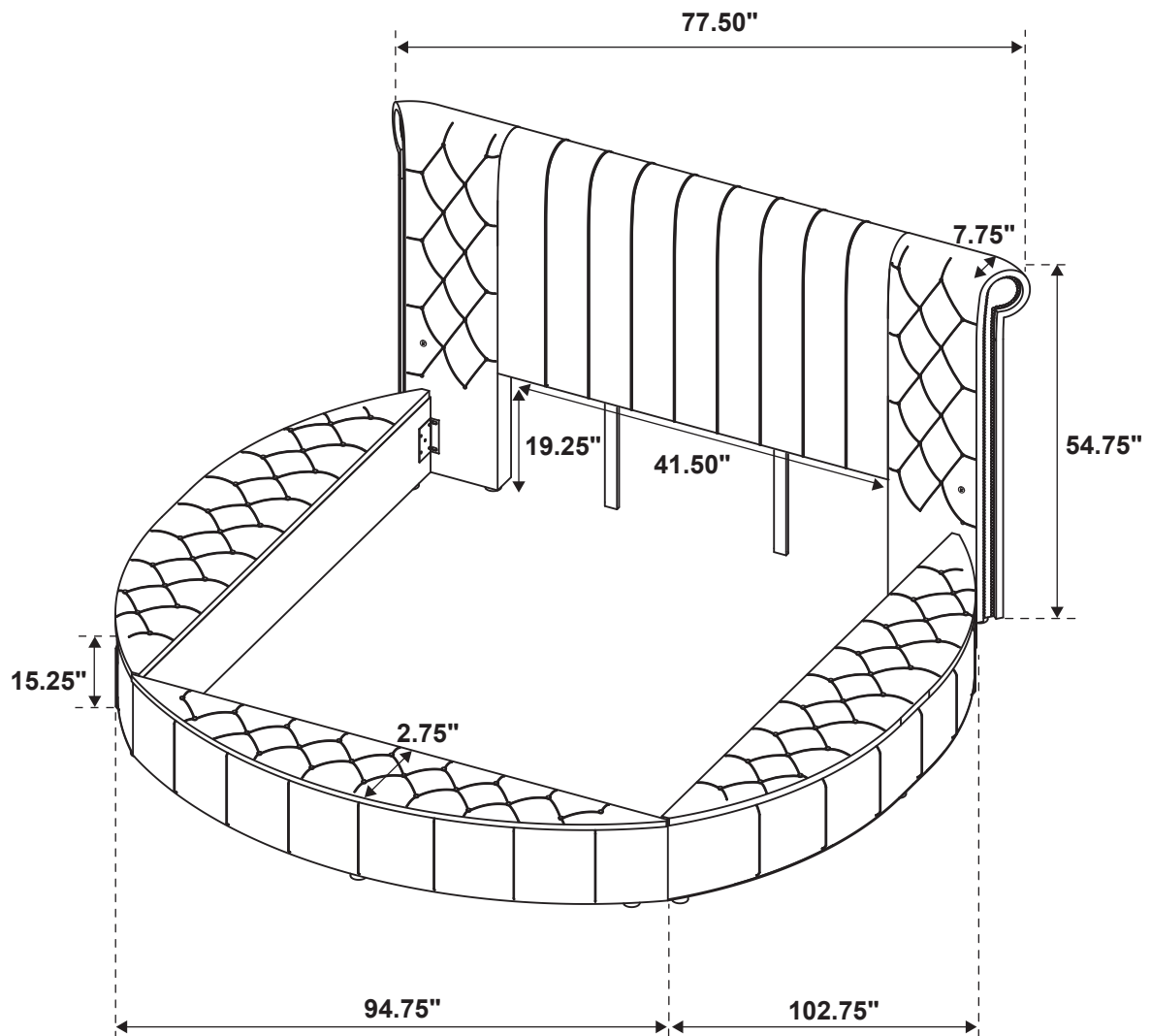

Note: Dimension tolerance $\pm 5\%$