

ASSEMBLY INSTRUCTIONS
COASTER FINE FURNITURE



Fine Furniture for every stage of life

182037
BAR CABINET

ITEM:182037



ASSEMBLY INSTRUCTIONS

ASSEMBLY TIPS:

1. Remove hardware from box and sort by size.
2. Please check to see that all hardware and parts are present prior to start of assembly.
3. Please follow attached instructions in the same sequence as numbered to assure fast & easy assembly.



WARNING!

1. Don't attempt to repair or modify parts that are broken or defective. Please contact the store immediately.
2. This product is for home use only and not intended for commercial establishments.

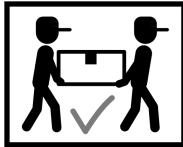

ASSEMBLY TIME 70 MINUTES

PARTS IDENTIFICATION

A SIDE GLASS
1576 x 282 x 5mm

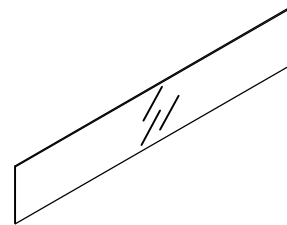

2PCS

B BACK GLASS
1576 x 384 x 5mm

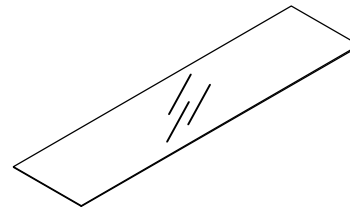

2PCS

C DOOR GLASS
1555 x 382 x 5mm

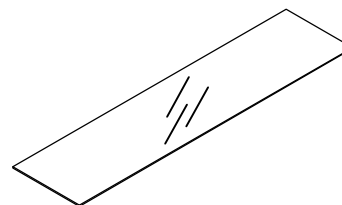

2PCS

D TOP PANEL

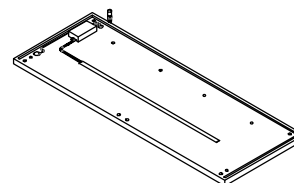

1PC

E BOTTOM PANEL

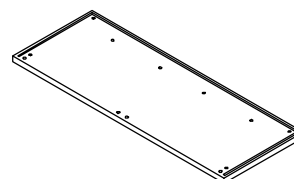

1PC

ITEM:182037 ASSEMBLY INSTRUCTIONS

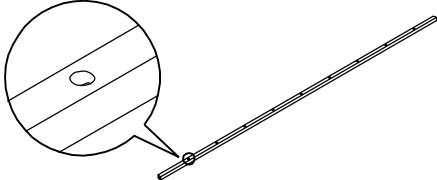

F BOTTLE HOLDER FRAME  18PCS

G CROSSBAR 1  4PCS

H CROSSBAR 2  4PCS

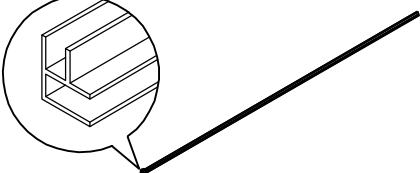
I PLASTIC BAR 1  2PCS

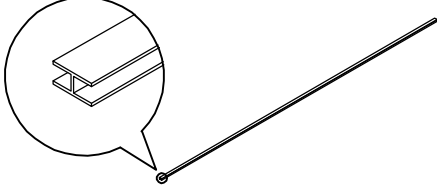
J PLASTIC BAR 2  1PC

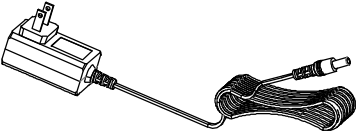
K POWER ADAPTER  1PC

L POWER CORD CLAMP  3PCS

















ITEM:182037

ASSEMBLY INSTRUCTIONS



Z

HARDWARE IDENTIFICATION

1	SHORT BOLT (1/4" x 25mm SR)		36PCS	9	HINGE 2		2PCS
2	LONG BOLT (1/4" x 42mm SR)		16PCS	10	METAL WITH ADHESIVE		4PCS
3	WASHER (1/4" SR)		16PCS	11	SMALL BOLT ($\phi 7$ x 6mm)		8PCS
4	CAP (13 x 13mm SR)		36PCS	12	HINGE INSERT		4PCS
5	SCREW (7# x 22mm SR)		4PCS	13	HANDLE		2PCS
6	PLASTIC FEET		4PCS	14	METAL CONTACT		2PCS
7	PLASTIC MAGNET		4PCS	15	ADHESIVE		4PCS
8	HINGE 1		2PCS	16	ALLEN WRENCH (4mm)		1PC

ITEM:182037



ASSEMBLY INSTRUCTIONS

STEP 1 Do not tighten until each step is completed or instructed.

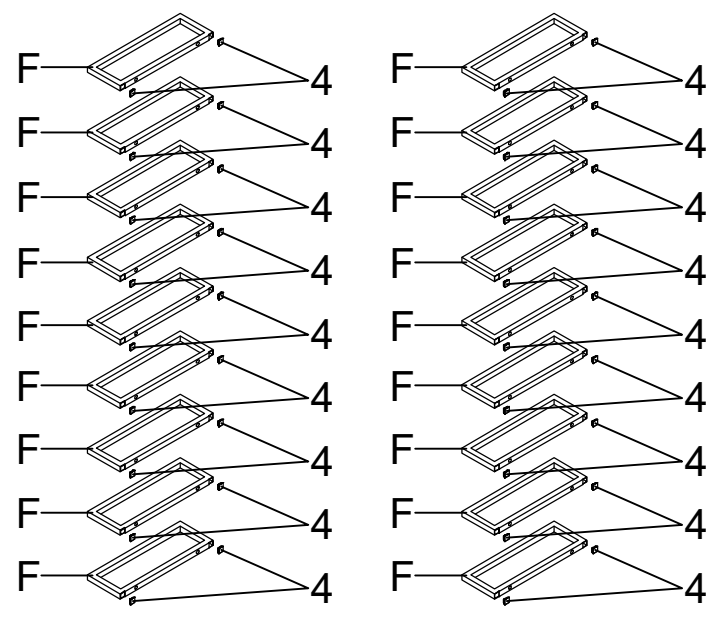
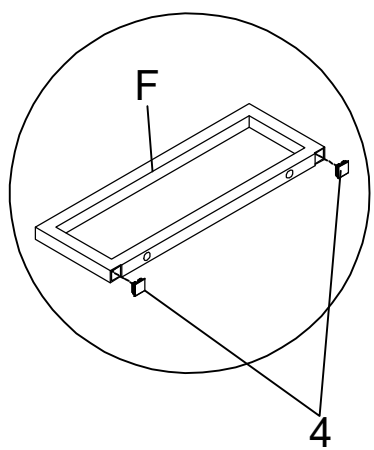

STEP 2

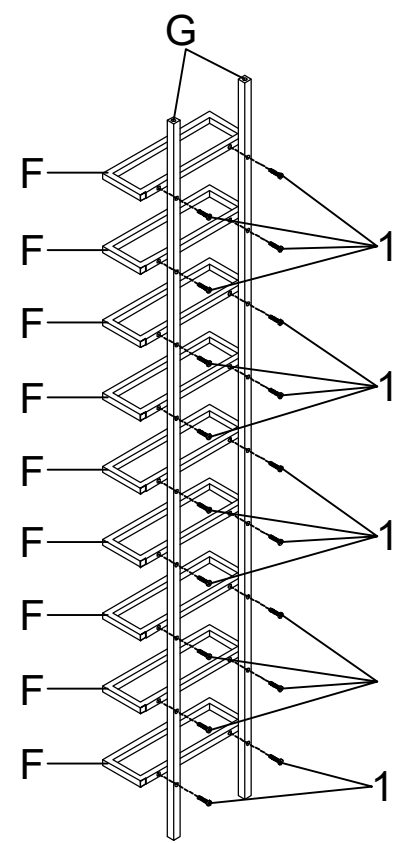
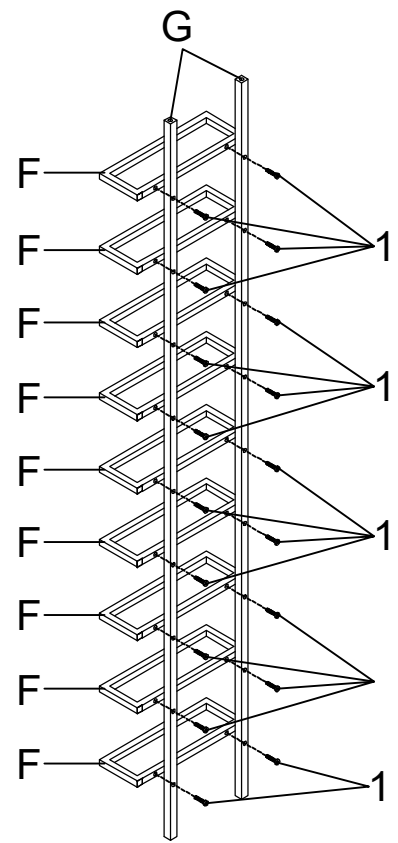

ITEM:182037

ASSEMBLY INSTRUCTIONS

STEP 3

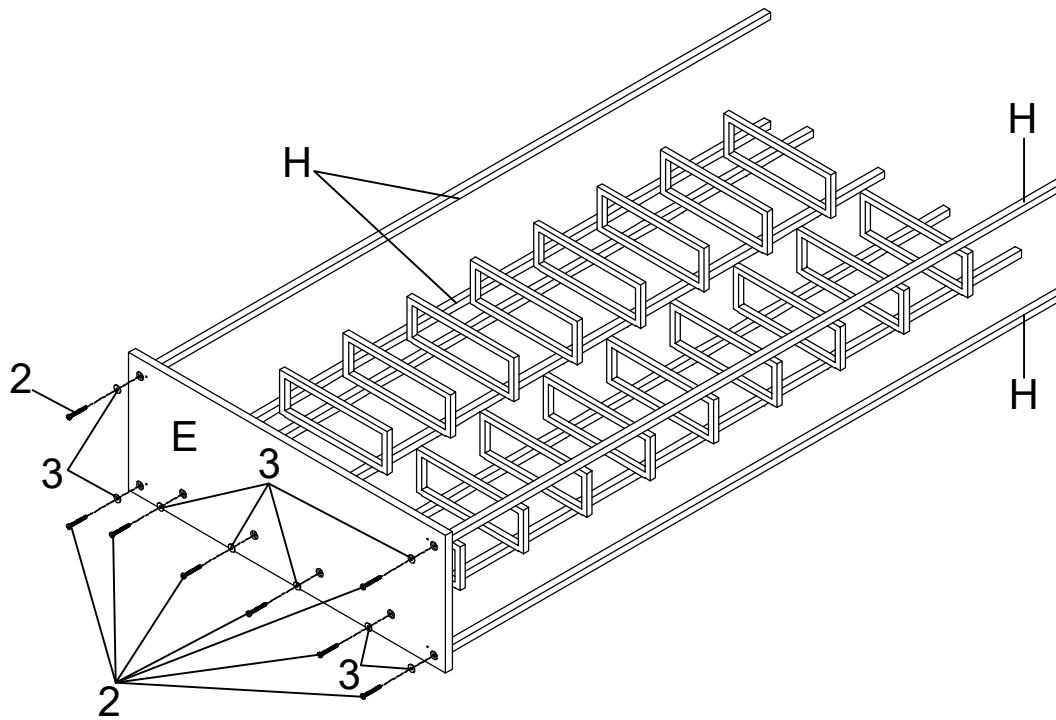

STEP 4

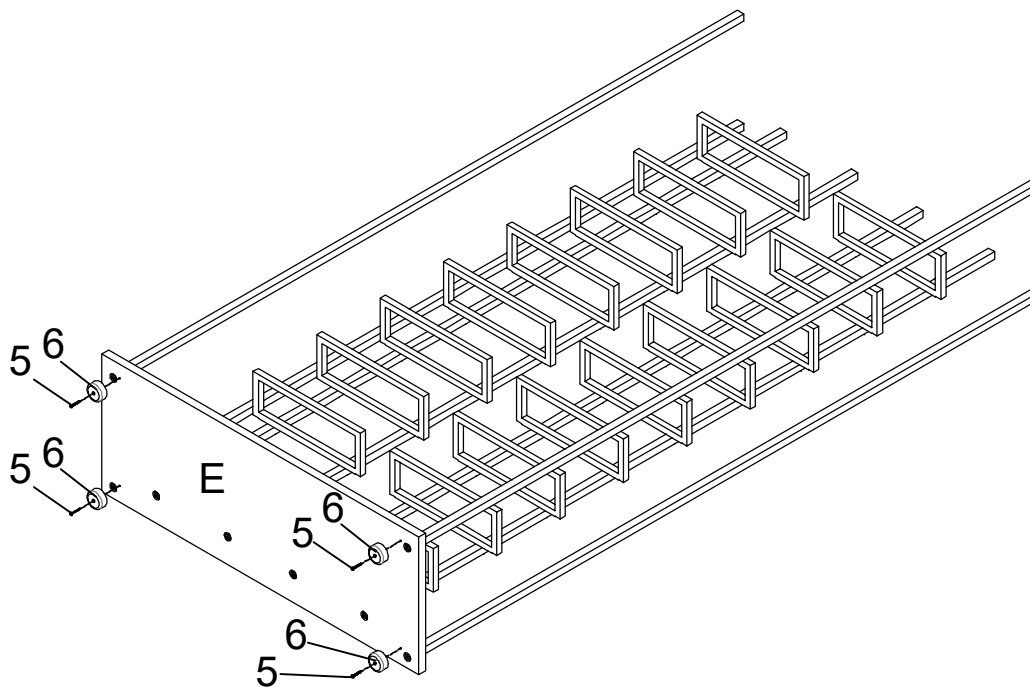

ITEM:182037

ASSEMBLY INSTRUCTIONS

STEP 5

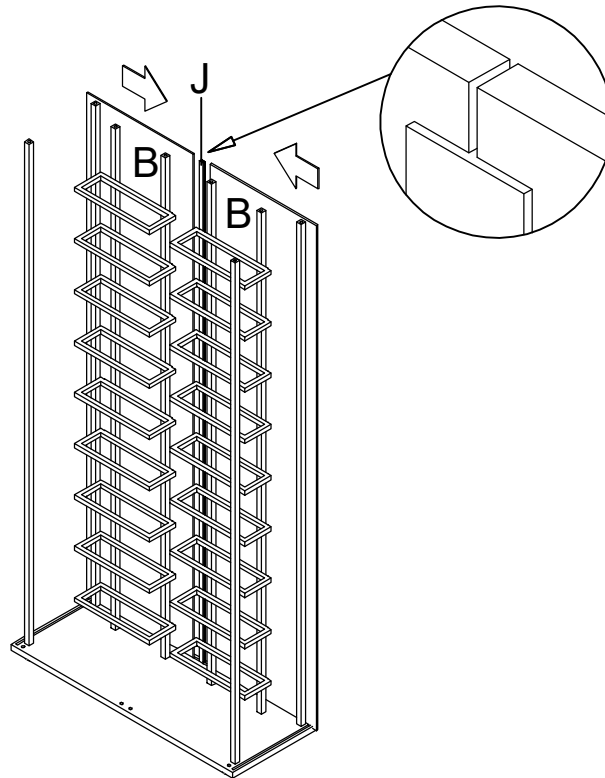

STEP 6

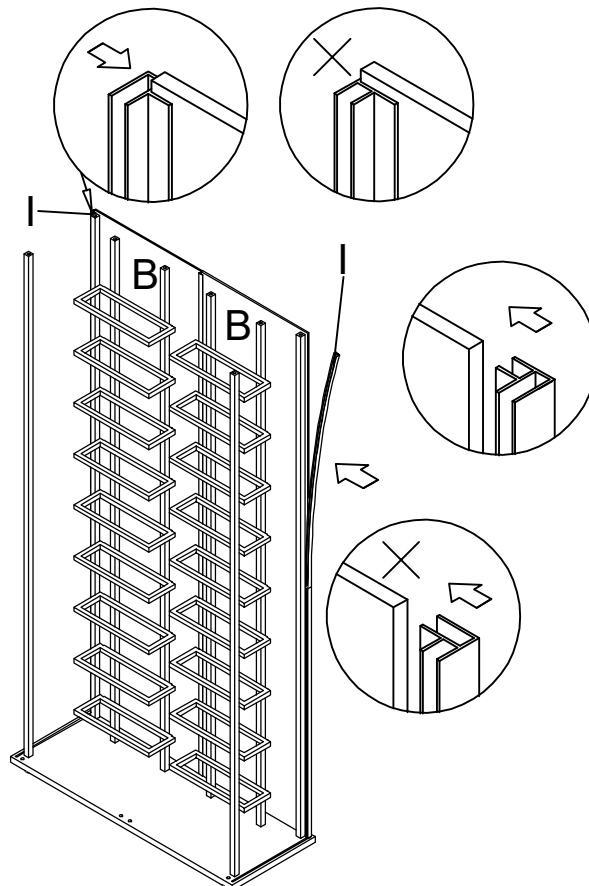

ITEM:182037

ASSEMBLY INSTRUCTIONS

STEP 7

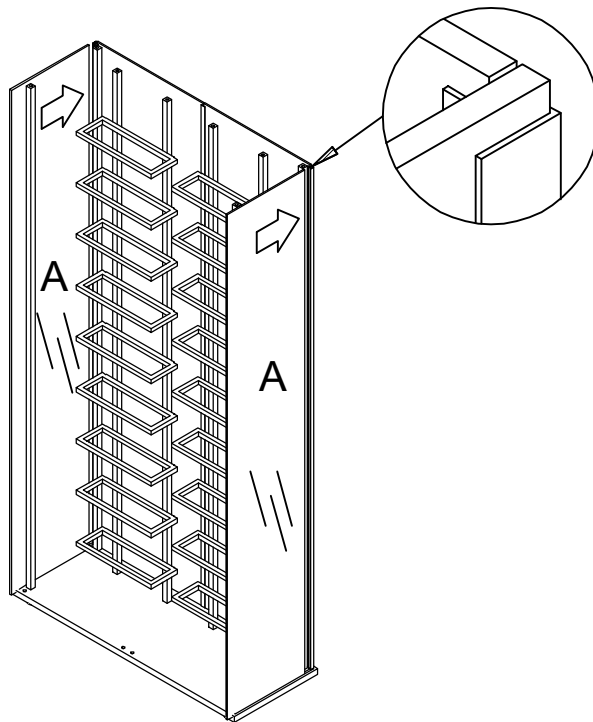

STEP 8

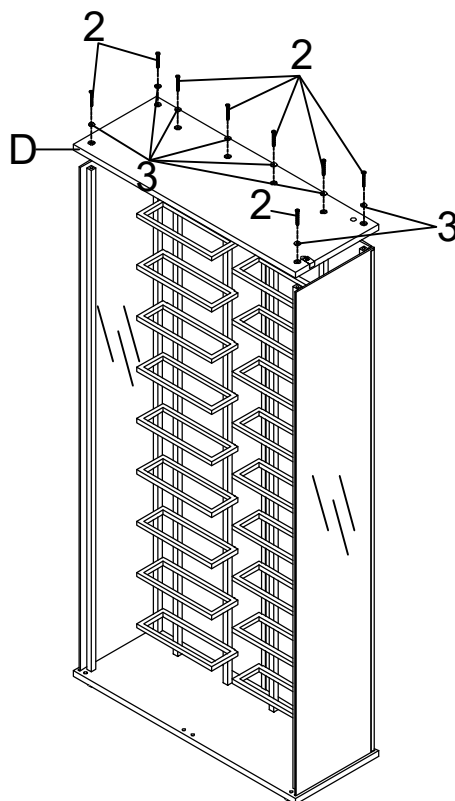

ITEM:182037

ASSEMBLY INSTRUCTIONS

STEP 9

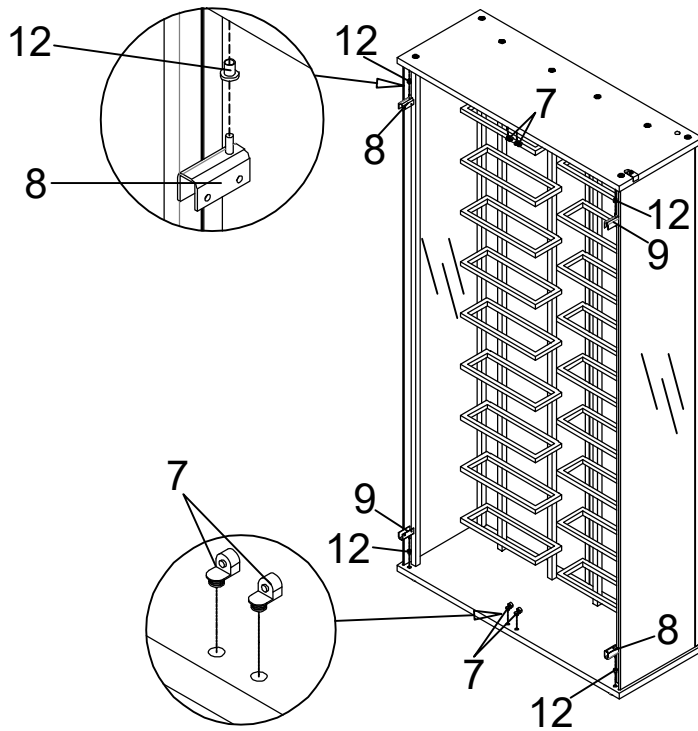

STEP 10

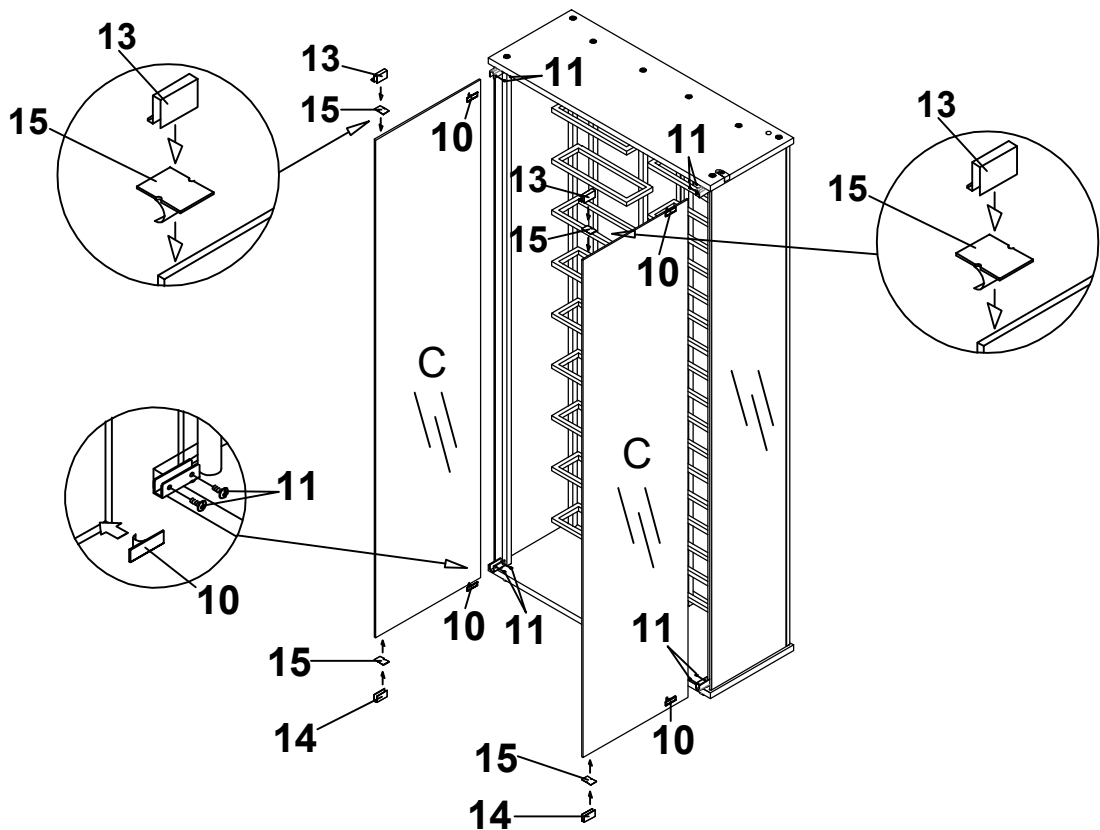

ITEM:182037

ASSEMBLY INSTRUCTIONS

STEP 11

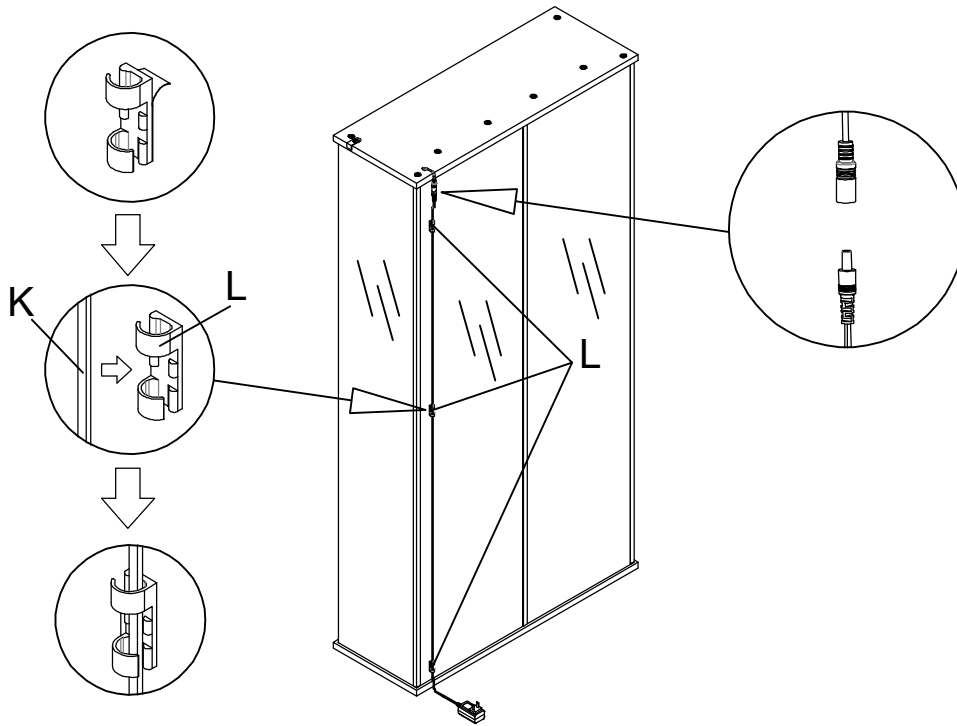

STEP 12
COMPLETE

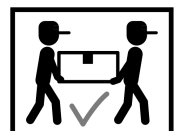
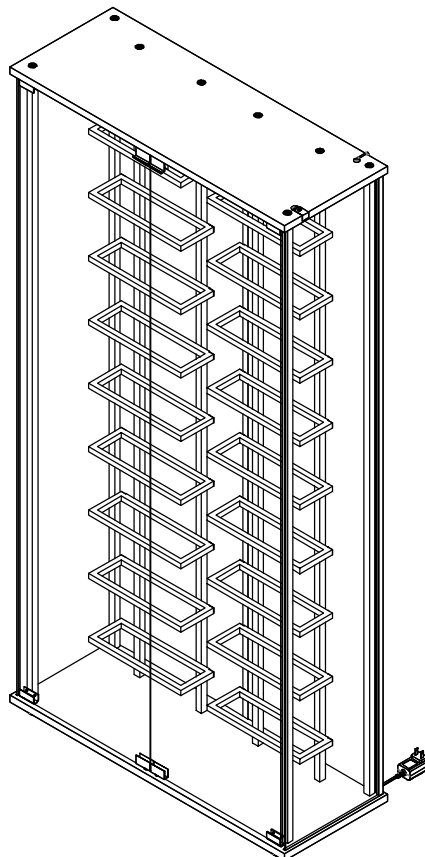

ITEM:182037 ASSEMBLY INSTRUCTIONS



Product Size : 800 X 298 X 1632 H (MM)
Product Size : 31.5" X 11.75" X 64.25"

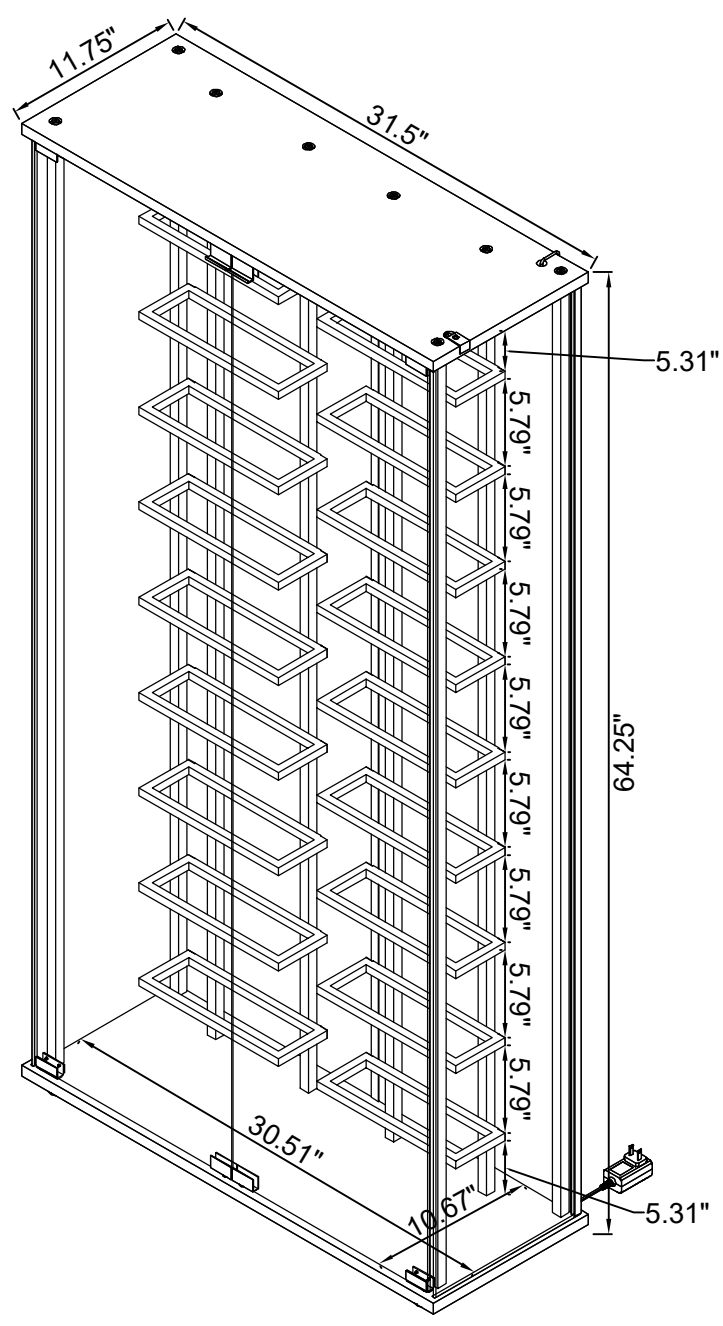

Note : Dimension tolerance $\pm 5\%$

ITEM: **182037**



ANTI-TIPPING INSTALLMENT INSTRUCTIONS

FURNITURE TIPPING RESTRAINT

WARNING

Injury may result from tipping furniture.
This restraint may protect against tipping furniture.
Do not allow children to climb on furniture.
This restraint is not a substitute for proper adult supervision.
Failure to detach this restraint before moving the furniture may result in injury and damage.

This tip restraint must be attached to a wall stud using long screw enclosed.

STEP 1

Attach a bracket securely to the back top rail of the furniture using short screw provided, through the smaller hole.

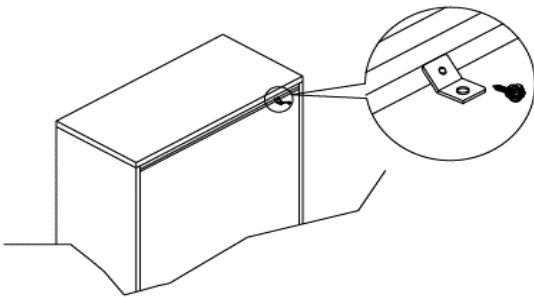

STEP 2

Locate the other bracket on the wall over a plastic wall stud and two inches below the mounting bracket secured to the back of the furniture. Attach the wall stud using the long screw provided, through the smaller hole.

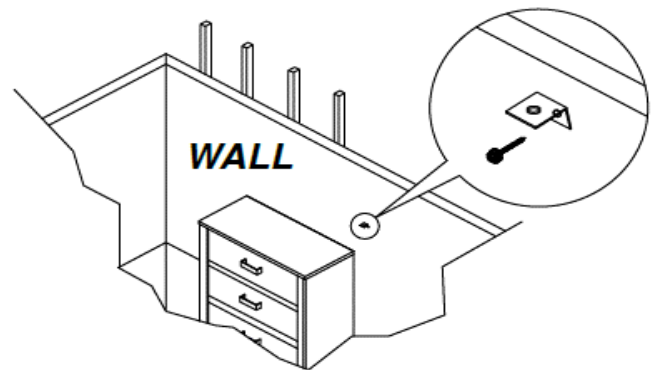

STEP 3

Place the furniture into position so both mounting brackets are vertically in line. Lace the end of the restraint strap through the larger hole in each mounting bracket. Bring both ends together and slide the flat end through the locking end and draw it through until all slack is removed. Confirm that the strap is securely laced and locked.

