

**ASSEMBLY INSTRUCTIONS**  
**COASTER FINE FURNITURE**

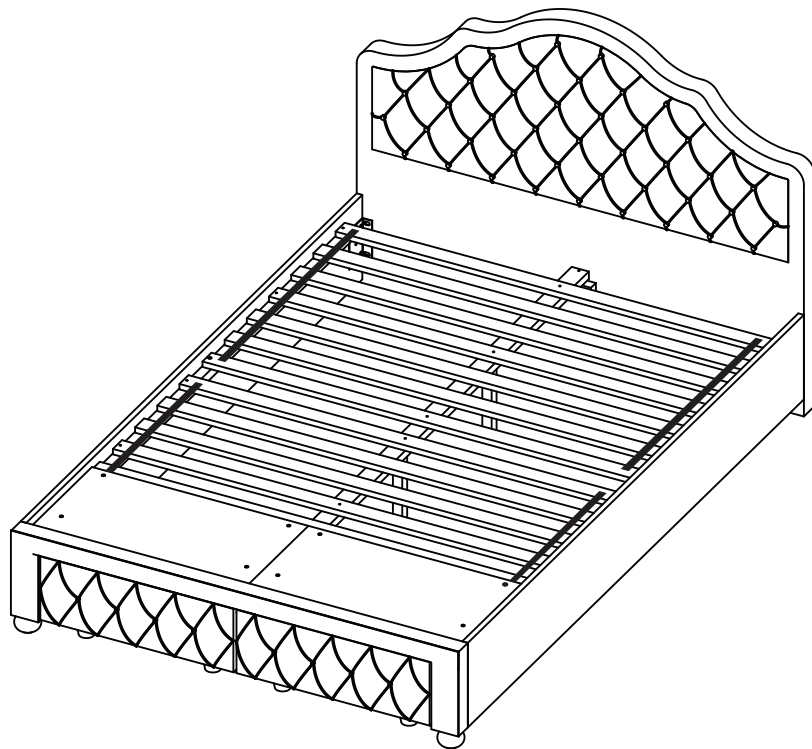

*Fine Furniture for every stage of life*

**460540F(B1-B3)**  
**Full Storage Bed**

# ITEM: 460540F(B1-B3)



## ASSEMBLY INSTRUCTIONS

### ASSEMBLY TIPS :

1. Remove hardware from box and sort by size.
2. Please check to see that all hardware and parts are present prior to start of assembly.
3. Please follow attached instructions in the same sequence as numbered to assure fast & easy assembly.



### WARNING !

1. Don't attempt to repair or modify parts that are broken or defective. Please contact the store immediately.
2. This product is for home use only and not intended for commercial establishments.



ASSEMBLY TIME

35 MINUTES

## PARTS IDENTIFICATION

### B1 (BOX 1)

A HEADBOARD

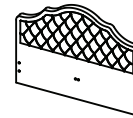

1PC

B CONCEAL PANEL



2PCS

### B2 (BOX 2)

C FOOTBOARD

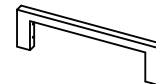

1PC

D BUN FOOT



2PCS

E CENTER RAIL



1PC

F WOOD CLEAT



1PC

G ROLL SLATS (7PCS)



2SETS

H BED SLAT SUPPORT WITH LEVELER



2PCS

I LEFT BED RAIL

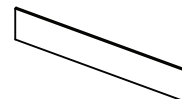

1PC

J RIGHT BED RAIL

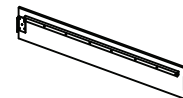

1PC

### B3 (BOX 3)

K LEFT FOOTBOARD DRAWER



1PC

L RIGHT FOOTBOARD DRAWER



1PC

M DRAWER LEG



8PCS

### NOTE:

Phillips head screw driver is required in the assembly process; however, manufacturer does not provide this item.

# ITEM: 460540F(B1-B3)



## ASSEMBLY INSTRUCTIONS

### ASSEMBLY TIPS :

1. Remove hardware from box and sort by size.
2. Please check to see that all hardware and parts are present prior to start of assembly.
3. Please follow attached instructions in the same sequence as numbered to assure fast & easy assembly.









### WARNING !





1. Don't attempt to repair or modify parts that are broken or defective. Please contact the store immediately.
2. This product is for home use only and not intended for commercial establishments.

## HARDWARE IDENTIFICATION

### Z-B2 (BOX 2) - HARDWARE PACK IS LOCATED IN 460540F(B2)

1	<b>ALLEN WRENCH</b> (Φ4 X 95mm - ZINC)		1PC
2	<b>SHORT BOLT</b> (Φ6 X 30mm - RBW)		8PCS
3	<b>LONG BOLT</b> (Φ6 X 45mm - RBW)		6PCS
4	<b>FLAT HEAD SCREW</b> (Φ4 X 32mm - RBW)		27PCS
5	<b>LOCK WASHER</b> (Φ6 - RBW)		8PCS
6	<b>FLAT WASHER</b> (Φ7 X 19mm X 2.0 - RBW)		8PCS

### Z-B3 (BOX 3) - HARDWARE PACK IS LOCATED IN 460540F(B3)

7	<b>SHORT BOLT</b> (Φ6 X 30mm - RBW)		2PCS
8	<b>LONG BOLT</b> (Φ6 X 45mm - RBW)		4PCS
9	<b>LOCK WASHER</b> (Φ6 - RBW)		4PCS
10	<b>FLAT WASHER</b> (Φ7 X 19mm X 2.0 - RBW)		4PCS

### NOTE:

Phillips head screw driver is required in the assembly process; however, manufacturer does not provide this item.

ITEM: **460540F(B1-B3)**



**ASSEMBLY INSTRUCTIONS**

**STEP 1**

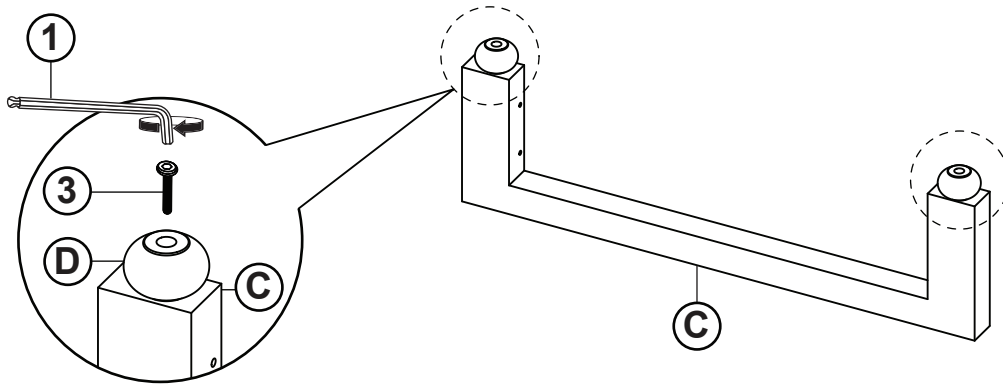

**STEP 2**

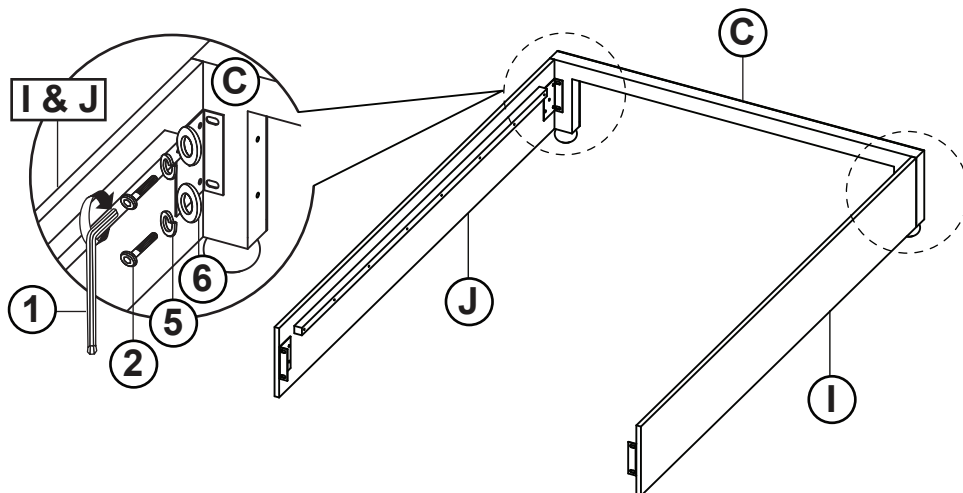

**STEP 3**

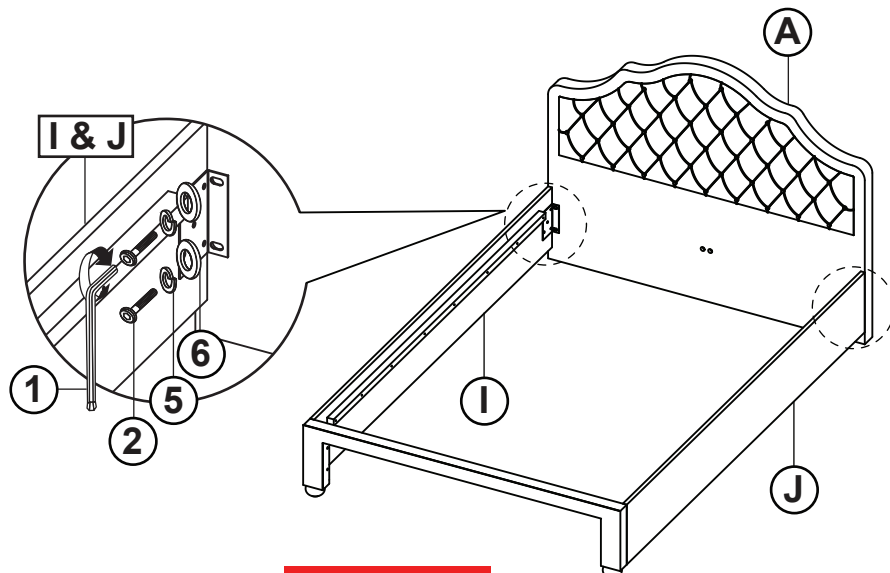

ITEM: **460540F(B1-B3)**



**ASSEMBLY INSTRUCTIONS**

**STEP 4**

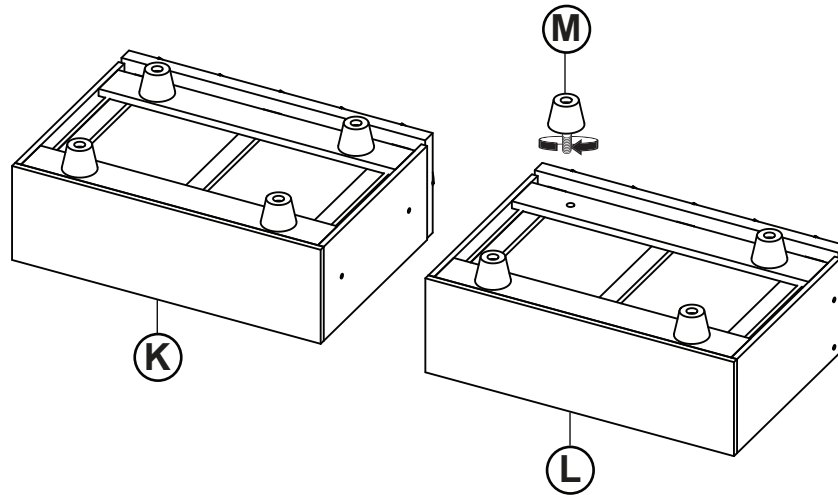

**STEP 5**

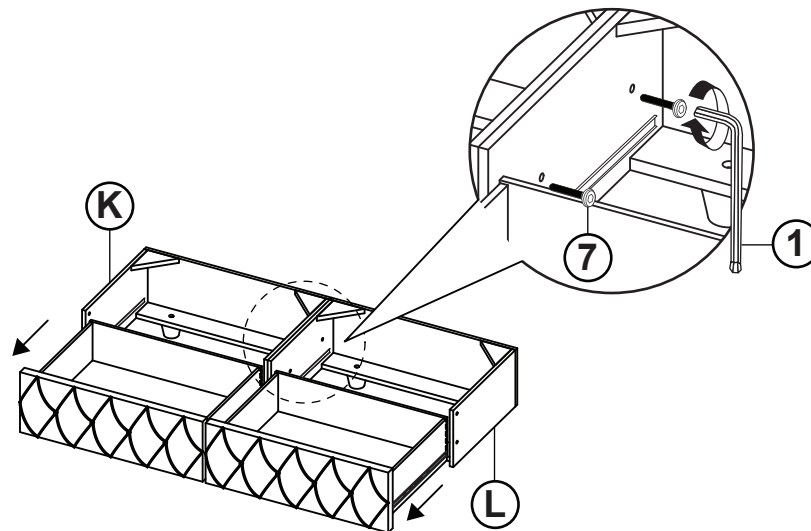

**STEP 6**

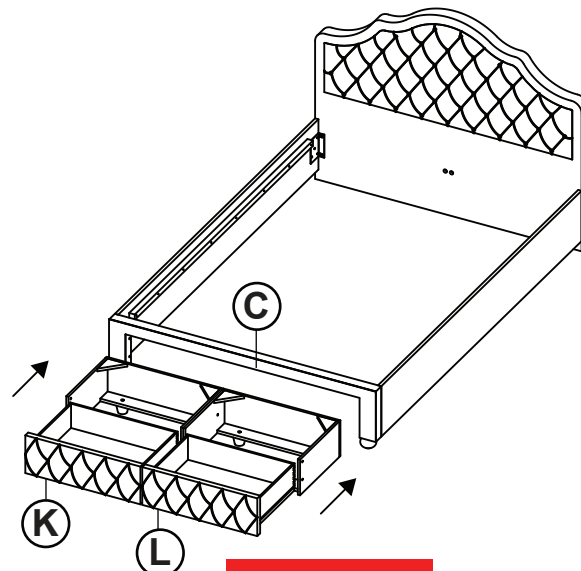

# ITEM: 460540F(B1-B3)



## ASSEMBLY INSTRUCTIONS

### STEP 7

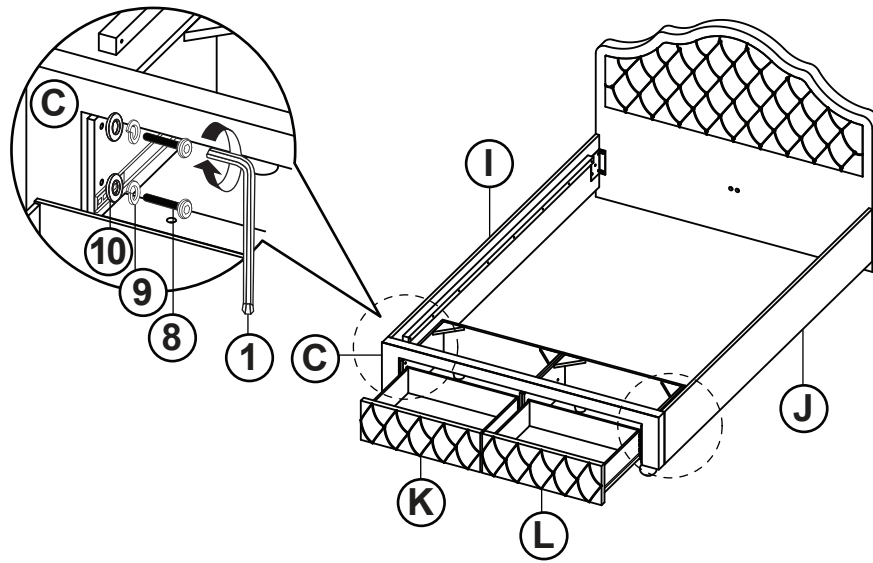

### STEP 8

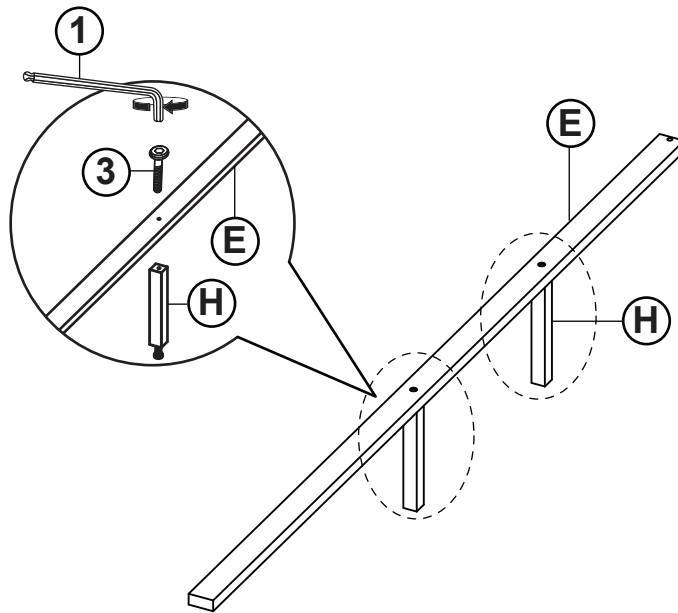

### STEP 9

Please ensure end of Center Rail (E) is being inserted into Footboard (C) so that the Center Rail (E) seated on the drawer box casing.

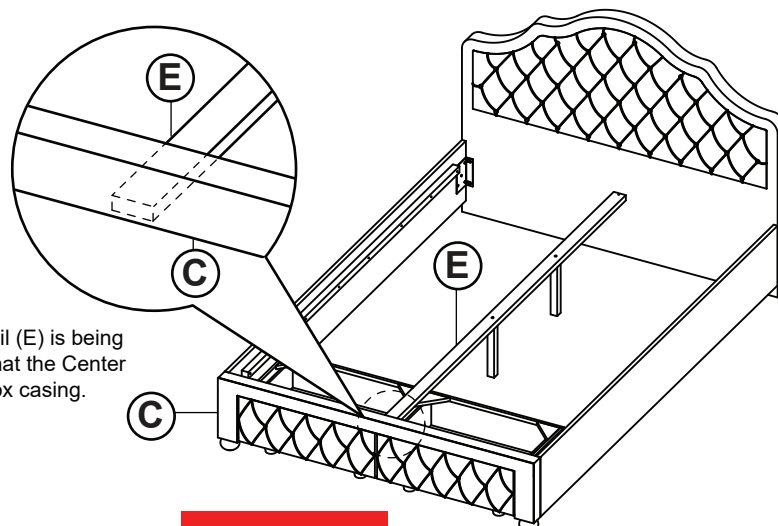

ITEM: **460540F(B1-B3)**



**ASSEMBLY INSTRUCTIONS**

**STEP 10**

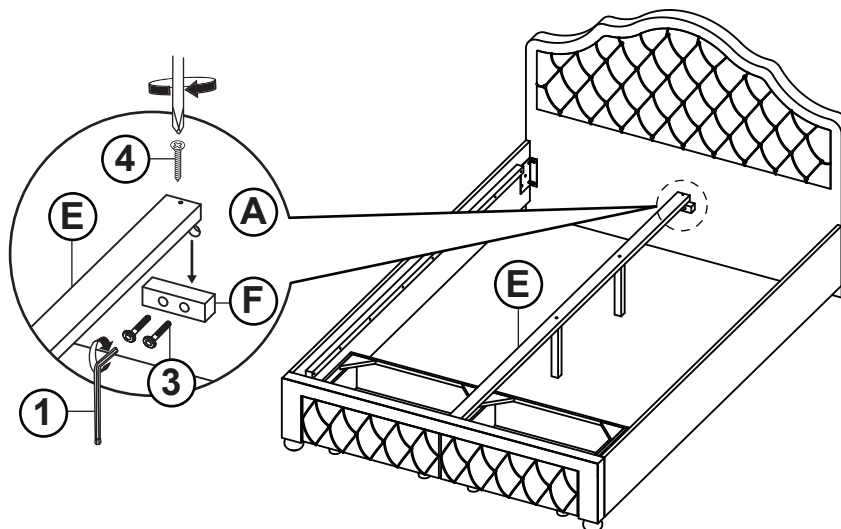

**STEP 11**

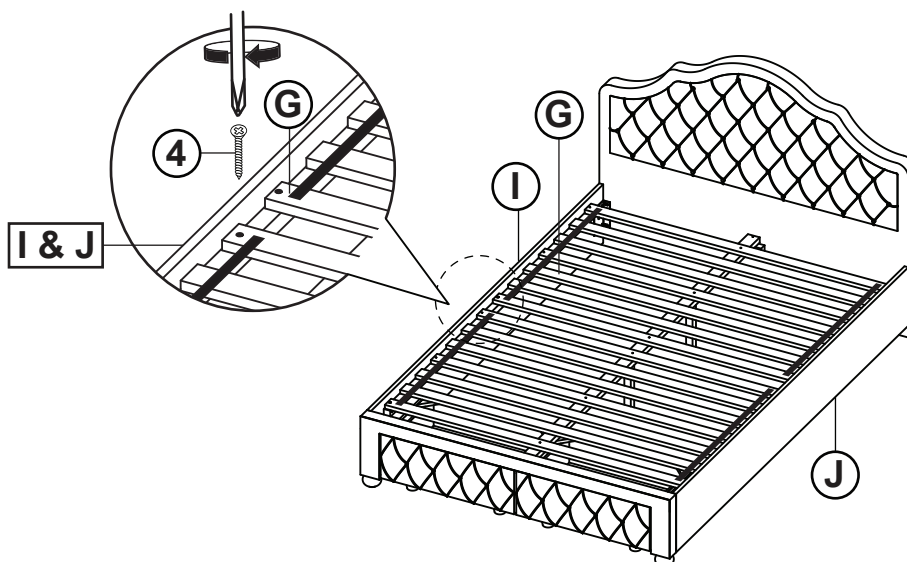

**STEP 12**  
**COMPLETE**

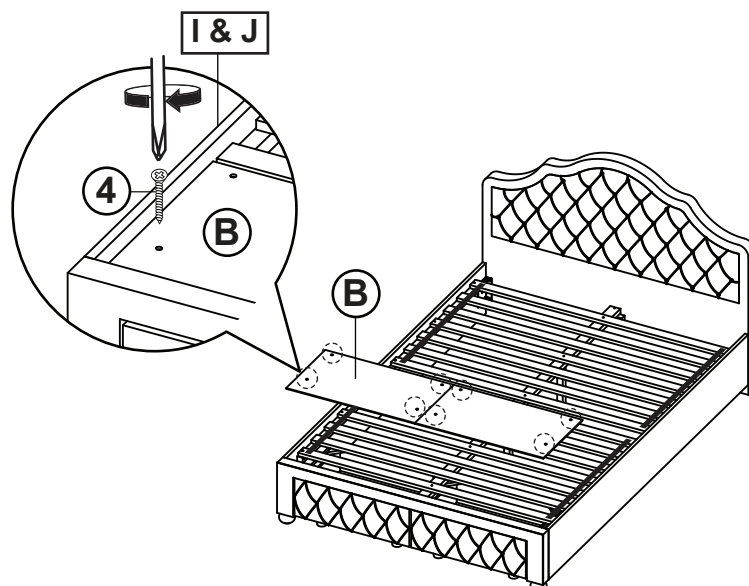

# ITEM: 460540F(B1-B3)



Inner Size : 55.00"W x 76.00"D

Inner Size of Drawer : 22.00"W x 14.50"D x 5.25"H x 0.50"T

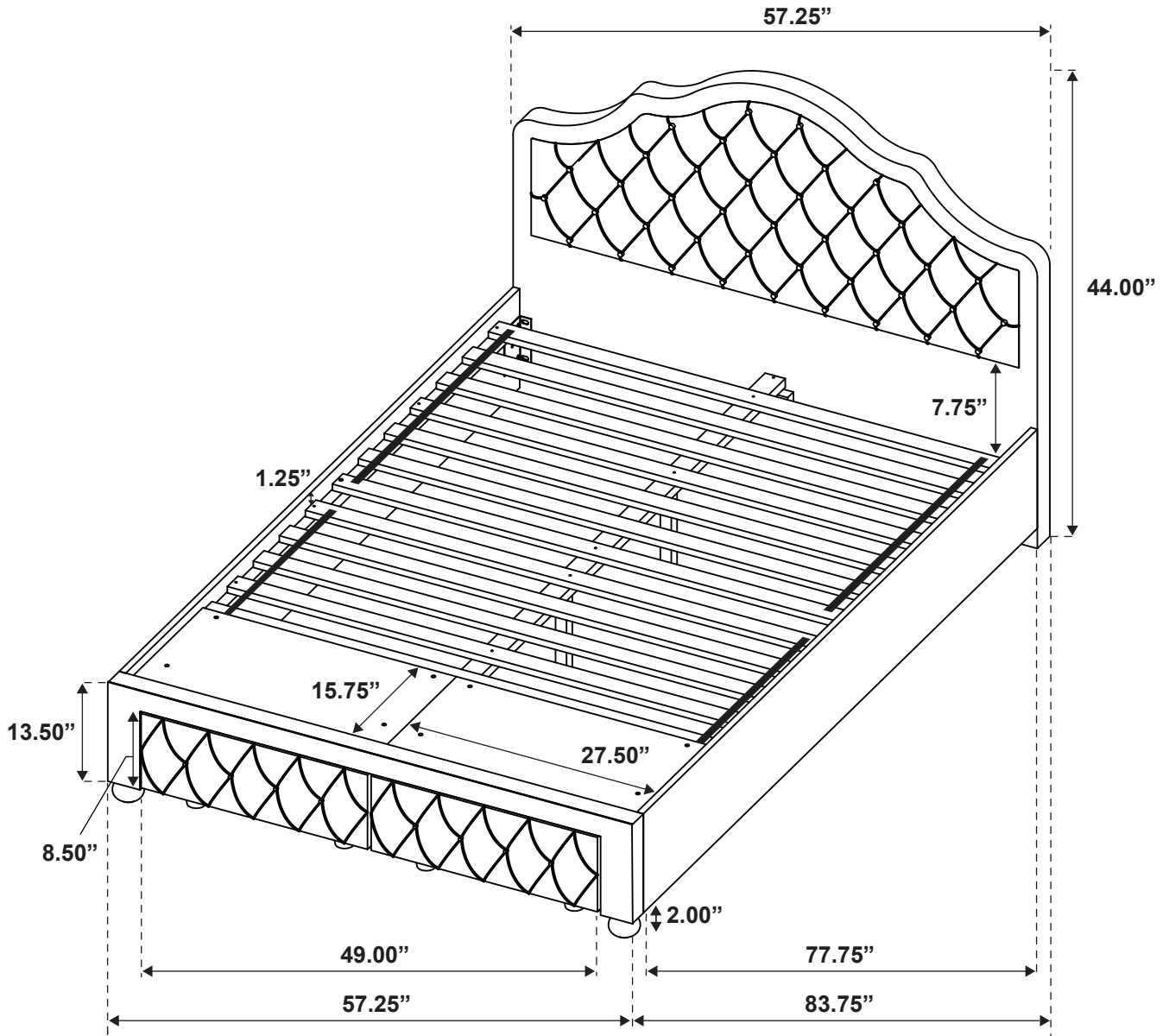

Note: Dimension tolerance  $\pm 5\%$